

**SAFE CONSTRUCTION AND
INSTALLATION OF ESCALATORS**

CODE OF PRACTICE

**RECOMMENDATIONS ADOPTED BY THE
INTERNATIONAL COMMITTEE FOR LIFT
REGULATIONS (CIRA) ON 6 JUNE 1972**



INTERNATIONAL LABOUR OFFICE - GENEVA

ISBN 92-2-101180-1

First published 1976

The designations employed in ILO publications, which are in conformity with United Nations practice, and the presentation of material therein do not imply the expression of any opinion whatsoever on the part of the International Labour Office concerning the legal status of any country or territory or of its authorities, or concerning the delimitation of its frontiers. The responsibility for opinion expressed in signed articles, studies and other contributions rests solely with their authors, and publication does not constitute an endorsement by the International Labour Office of the opinions expressed in them.

ILO publications can be obtained through major booksellers or ILO local offices in many countries, or direct from ILO Publications, International Labour Office, CH-1211 Geneva 22, Switzerland. A catalogue or list of new publications will be sent free of charge from the above address.

Table of contents

	<u>Page</u>
Foreword	iii
Introduction	1
1. Scope	3
2. Definitions	4
3. Enclosure, surrounds, construction and lighting	5
4. Enclosures for the machines, associated equipment and the gears for driving and return	8
5. Moving handrail	9
6. Steps	11
7. Step drive	13
8. Inclination of the escalator and guiding of steps ...	14
9. Clearance between steps and between steps and balustrades	15
10. Machine	16
11. Electrical installations and equipment	18
12. Starting and stopping	19
13. Notices, operating instructions and signals	21
14. Maintenance and inspection of escalators	23
Index	29

Foreword

The International Labour Office and the International Committee for Lift Regulations (CIRA)¹ have jointly prepared the Code of Practice for the safe construction and installation of electric passenger, goods and service lifts, which was published in 1971. Since then CIRA has established this Code of Practice for escalators.²

The International Labour Office, while it has not submitted this text to any of its consultative or executive bodies, deemed it worth while to publish this Code of Practice in the Occupational Safety and Health Series, thus ensuring its broad dissemination.

This Code of Practice fills a gap at the international level, in view of the ever increasing number of escalators installed in industrial premises as well as in buildings open to the public.

¹ CIRA has been established in accordance with a decision taken by the delegations accredited to the International Meeting of Experts on Safety Regulations for Passenger, Goods and Service Lifts (Milan, 20-24 May 1957).

² The following experts participated in its preparation: Mr. H. EGLI, Chairman of CIRA, formerly Head of the "Büro für Aufzugsanlagen", Zurich; Mr. C. VOLPI, Honorary Member of CIRA, formerly Professor at Milan Polytechnic School, Chairman of the Committee for Lift Regulations; Mr. M. BAUMGARTNER, representative of the European Mechanical Handling Federation, Section VII (Lifts and Escalators); Mr. R.T. EYELTAUER (Austria), Chairman of the Committee on Lifts of the "Österreichisches Normungsinstitut (ÖN); Mr. C. PERRETTI SARTORI (Italy), National Institute for the Prevention of Accidents (ENPI), Head of the Inspection Department for Lifts and Lifting Equipment; Mr. J.C.R. POTTERGILL (United Kingdom) member of the Technical Committee of the National Association of Lift Manufacturers and of the Lift Committee of the British Standards Institution; Mr. S. HAHN-WOERNLE (Federal Republic of Germany) representing the German manufacturers of lifts; Mr. L.P.J. HUBERTS (Netherlands), Director of the "Nederlands Instituut voor Lifttechniek"; M.H. KLÄY (Switzerland), Head of the "Büro für Aufzugsanlagen", Zurich; Mr. J. STAAL, representative of the European Mechanical Handling Federation, Section VII (Lifts and Escalators); Mr. J. TRAZET (France), representative of the "Chambre syndicale des ascenseurs et monte-charge"; Mr. B. ULWARD (Sweden); Mr. F. SPOON, formerly President of CIRA, formerly Director of the "Nederlands Instituut voor Lifttechniek"; the International Labour Office representatives attended the meetings during which this Code of Practice was drafted. Mr. MAHRER, representative of the European Mechanical Handling Federation, Mr. MORLEY, representative of the United Kingdom and Mr. SCHROEDER, representative of the Federal Republic of Germany also attended the meetings. Mr. P. LAUTMANN, chief engineer of SOCOTEC - Bureau Securitas (France), was in charge of the Secretariat of the Committee.

Introduction

This document aims at defining a code of practice related to escalators with a view to safeguarding people and goods against the risks of accident. It is not merely based on a compilation of standards already in force; it has been drawn up by experts who, while perfectly aware of the existing regulations, some of which are truly up to date, have adopted the following principles:

(1) For each of the components, which together make up an escalator, an assessment of the risks associated has been made and a recommendation for safety has been drawn up accordingly.

(2) The general technical rules applicable to all electrical, mechanical, steel construction and building design have not been mentioned, because it was assumed, a priori, that all components referred to in this Code

(a) are correctly calculated, of sound electrical and mechanical design, made of suitable, good quality material, of adequate strength and free from defects,

(b) satisfy the national fire regulations,

(c) are kept in good repair and working order.

(3) As far as possible the recommendations set out the requirements that materials and equipment have to meet.

(4) When, for the sake of clarity, mention is made of a particular design, this should not be considered the only one possible; any other solution in accordance with the principle recommended may be applied if it is equivalent in operation and at least equally safe.

Accidents to goods and people

Study of the various kinds of accidents possible to good and people with escalators has led to the following classification:

(1) Kinds of possible accidents: (a) trapping, in particular between steps, between steps and balustrades, between steps and combs, between moving handrail and balustrade, near various obstacles (floors, adjacent escalators, etc.); (b) fall, in particular at the entrance and exit and in case of accidental reversal of the direction of movement; (c) fire; (d) electric shock; (e) damage to material; (f) wear; (g) corrosion.

- (2) Persons to be safeguarded: (a) the users; (b) people circulating around the escalator; (c) maintenance and service personnel.
- (3) Goods to be safeguarded: (a) objects carried by the users; (b) components of the installation; (c) the buildings housing the escalator.

Notes

- (a) For the sake of convenience a subject may be mentioned in various paragraphs of this Code of Practice.
- (b) The illustrations are included after the text.
- (c) An index will be found at the end of the text.
- (d) The text of this Code of Practice was originally drawn up in French.

1. Scope

1.0.1. In principle the present Code is meant for new installations.

1.0.2. For existing escalators:

- (a) escalators should only be kept in operation if they do not present serious risk of accident; it would be desirable to bring them in line with the requirements for new installations in due course and to a degree consistent with the technical and economic means available and according to the accident probability;
- (b) escalators should be subjected to periodic inspections; inspections, if not made by a public authority, should be made by an organisation or person licensed by the public authority (provided there is a law to do so in the country concerned) and as far as possible independent of the manufacturer and the organisation responsible for the maintenance.

1.0.3. The present Code will be supplemented by provisions specifically relating to escalators used in public places (railways, underground railways, airports, underground passages, etc.).

2. Définitions

2.0.1. The following definitions are set out to indicate the precise technical sense in which the listed terms have been used in this document. It should be noted that in some English-speaking countries some of these terms in their current usage have slightly different senses:

- Balustrades - step side of the enclosure of the escalator extending from the steps upwards to the moving handrail.
- Escalator - continuous moving stairway driven by a motor for the conveyance of passengers in the upward or downward direction.
- Speed governor - device which causes the escalator to stop when its speed exceeds a predetermined figure.
- Machine - driving unit comprising motor, gear and brake.
- Handrail - the moving part intended to serve as a hand hold for the passengers.
- Step - the part of the escalator intended for the passengers to stand on.
- Comb - the part of the escalator fitted at the entrance and exit to facilitate the movement of a passenger from the step to the landing and vice versa.
- Contract speed - the speed measured along the incline of the escalator, at which the escalator has been designed to operate as stated by the manufacturer.

3. Enclosure, surrounds, construction and lighting

3.1. ENCLOSURE OF THE ESCALATOR

3.1.1. (1) The parts of the escalator other than that part of the handrail and the steps available for the user, should be completely enclosed within imperforate panels.

(2) In this enclosure the only openings permissible if required are the following:

- (a) inspection doors and trap doors,
- (b) apertures for ventilation.

Exception: The requirements specified in 3.1.1.(1) need not be applied to the underside of the escalator, if the local fire regulations do not object.

3.1.2. The enclosure of the escalator should have adequate mechanical strength and rigidity.

3.2. INSPECTION DOORS AND TRAP DOORS

3.2.1. Inspection (doors or) trap doors should only be provided when necessary for the inspection and maintenance of the equipment.

3.2.2. Inspection (doors or) trap doors may only be opened by a lock or special tool which should be kept by authorised persons. A triangular type key could be used similar to that used for the locking of flameproof equipment.

3.2.3. Inspection doors and trap doors should be imperforated and conform to the same conditions as required for the enclosure (see 3.1.2.).

3.3. APERTURES FOR VENTILATION

3.3.1. It should not be possible to touch any moving part through a ventilation aperture.

3.4. BALUSTRADES (fig. 1)

3.4.1. Balustrades should be installed on each side of the escalator.

3.4.2. The balustrades should form a continuous surface and consist of smooth elements.

3.4.3. (1) Glass may be used, provided it is safety glass which, in the event of breakage, would not present hazard to a person using the escalator in a normal manner.

(2) The use of wire glass should not be permitted.

3.4.4. Protrusions and indentations should not present sharp edges.

3.4.5. The profile of balustrades should be symmetrical to the centre vertical section of the escalator.

3.4.6. (1) Balustrades should have no parts providing a foot hold.

(2) At and above step tread level, for a vertical height "A" (fig. 1) of at least 2 cm:

(a) the balustrades should be vertical,

(b) the balustrades should be extremely rigid, smooth and have a coefficient of friction reduced to a minimum.

(3) Above the zone defined in 3.4.6(2) the inclination "α" of the balustrade should be greater than 25° to the horizontal.

Exception: This provision need not apply to that part of the balustrade in the immediate vicinity of the handrail.

(4) The width "B", measured horizontally, of any part inclined at an angle of less than 45° to the horizontal should be less than 12 cm.

(5) Joint cover, when used, should be positioned and made in a manner that will not give rise to risk of trapping, particularly of feet.

3.4.7. The dimension "C" (fig. 1) measured at any point should be such that:

$$Z < C < (Z + 33 \text{ cm})$$

3.5. PROTECTION UNDER THE ESCALATOR

3.5.1. In positions where persons may circulate under the escalator an enclosure should be provided to protect them from moving parts (including steps) and falling dust.

3.5.2. It should be possible to clean this enclosure without danger to prevent the accumulation of dust.

3.6. SURROUNDS OF THE ESCALATOR

3.6.1. There should be sufficient space at the exit of the escalator to allow users to disperse easily.

3.6.2. In the case of successive escalators without intermediate exits each escalator should have the same passenger handling capacity.

3.6.3. For a minimum distance of 50 cm measured from the root of the comb teeth (point "L" in fig. 2 and 3) the landing floor should have a non-slip surface.

3.6.4. The clear height "S" above the steps of the escalator should not be less than 2.10 m at all points.

3.6.5. A vertical barrier with a minimum height "T" of 25 cm, having no sharp edges, such as an imperforate triangle, should be placed above the balustrades over an adequate distance wherever a risk of nipping or trapping exists (at floor intersections, crossing points with another escalator). (See example in fig. 3.)

Exception: It may not be necessary to comply with this recommendation when the distance "D" between the axis of the moving handrail and the obstacles envisaged is equal to or greater than 50 cm (fig. 1).

3.7. CONSTRUCTION OF THE ESCALATOR

3.7.1. The escalator, with the exception of the motor and the steps, should be designed to support a load calculated on the basis of 400 kg/m² for the total of the exposed surface of the steps "Δ" (fig. 4).

3.8. LIGHTING

3.8.1. The escalator and its surrounds should be sufficiently and adequately lit, especially the zone of the combs.

3.8.2. The lighting intensity measured on the face of the steps and in the zone of the combs should be no less than the lighting intensity on the landing at the entries of the escalator.

3.9. PROTECTION AGAINST FIRE

3.9.1. The escalator and its surrounds should comply with the regulations relating to the protection against fire in force in the country where the escalator is installed.

3.10. PROTECTION AGAINST WEATHER CONDITIONS

3.10.1. The escalator should be protected from the weather, when the material has not been specially designed for exposed conditions.

4. Enclosure for the machines, associated equipment and the gears for driving and return

4.1. GENERAL

4.1.1. The machines, associated equipment and the gears for driving and return should only be accessible to maintenance personnel.

4.1.2. Under no circumstances should the enclosures for these parts be used for purposes other than for the escalator.

4.2. ACCESSIBILITY

4.2.1. Access up to the machinery enclosures should be easy and safe. In particular this access should comply with the recommendations issued on this subject by the International Labour Office and with national regulations relating to occupational safety. The minimum height above the access should be 1.80 m.

4.2.2. Ladders provided for access to inspection doors and enclosures for machines, associated equipment and gears for driving and return should not be liable to slip or to turn over when in use; these ladders should be reserved for the maintenance personnel and should at all times be at their disposal in the vicinity.

4.3. CONSTRUCTION AND EQUIPMENT OF ENCLOSURES FOR THE MACHINES, ASSOCIATED EQUIPMENT AND THE GEARS FOR DRIVING AND RETURN

4.3.1. The enclosures should be constructed to withstand the stresses to which they will normally be subjected. When the tensioning devices comprise counterweights, the steel work and the floor should be able to support and retain them, in case they accidentally become detached.

4.3.2. (1) Access for maintenance personnel to switches, fuses and control panel connections should be easy and safe.

(2) Access to other parts should be as easy as possible.

4.3.3. Electric lighting of the enclosures should be ensured by a portable lamp permanently available in one of the enclosures and, if safety requires this, by one or more additional fixed lighting point. The lighting should be sufficient and independent of the power supply to the machine. One or more socket outlets should be provided.

4.3.4. In each enclosure near the access a switch should be installed to stop the escalator and to hold it stationary.

5. Moving handrail

5.1. NECESSITY FOR A MOVING HANDRAIL

5.1.1. On the upper surface each balustrade should be provided with a handrail moving in the same direction and at substantially the same speed as the steps.

5.2. CONTINUATION AHEAD OF THE COMB (fig. 3)

5.2.1. The horizontal portion of the moving handrail should project at each extremity for a distance "U" of at least 30 cm beyond the root of the comb teeth (point "L" in fig. 2 and 3).

5.3. PROFILE AND POSITION

5.3.1. The profile of the handrail and its position above the balustrade should be such as to prevent the danger of pinching the fingers between the moving handrail and the balustrade, or between the handrail and any fixed part of the building.

5.3.2. The width "E" of the handrail should be between 7 and 10 cm (fig. 1).

5.3.3. The distance "F" between the handrail and the edge of the balustrade should not exceed 5 cm (fig. 1).

5.4. PROTECTION AT THE POINT OF ENTRY INTO THE BALUSTRADE

5.4.1. The lowest point of entry of the handrail into the balustrade should lie at a distance "G" from the floor, which should be no less than 10 cm and not exceed 25 cm (fig. 1 and 3).

5.4.2. The horizontal distance "W" between the furthest point reached by the handrail and the point of entry into the balustrade should be at least 30 cm (fig. 3).

5.4.3. At the point of entry into the balustrade a means of protection for fingers and hands should be installed.

5.5. HEIGHT ABOVE THE STEPS

5.5.1. The vertical distance "J" between the handrail and the nose of the steps should be no less than 85 cm and not exceed 1.10 m (see fig. 1 and 3).

5.6. DISTANCES BETWEEN HANDRAILS

The distance "K" between the axis of the handrails should not exceed the value "Z" (fig. 1 and 4) plus 45 cm.

5.7. GUIDING

5.7.1. The moving handrails should be guided and tensioned so that they will not leave their guides in normal operation.

6. Steps

6.1. DIMENSIONS (fig. 4)

6.1.1. The dimension "X" should not exceed 24 cm.

6.1.2. The dimension "Y" should be no less than 38 cm.

6.1.3. The dimension "Z" should be no less than 40 cm nor exceed 1.10 m.

6.2. CONSTRUCTION OF THE STEPS (fig. 2)

6.2.1. The steps should be able to support a load of 450 kg/m² without such deformation that would prejudice the proper functioning of the escalator.

6.2.2. The top surface of the steps should be horizontal in the area used by the passengers; it should be grooved in the direction of movement,

6.2.3. (1) The width of the grooves "M" should not exceed 7 mm.

(2) Their depth "N" should be no less than 10 mm.

(3) The distance "P" between the axis of two adjoining grooves should not exceed 10 mm.

(4) The steps should not finish with a groove at the side of the balustrade.

6.2.4. The steps risers "Φ" (fig. 4) should be very rigid, smooth or grooved vertically and have a minimum coefficient of friction.

6.3. COMBS

6.3.1. Combs should be placed at the entrance and the exit of the escalator to ensure safe and easy movement of passengers between the step and landing.

6.3.2. The teeth of the combs should penetrate into the grooves of the steps (fig. 2).

6.3.3. The ends of the teeth should not have too great a radius of curvature to avoid the risk of trapping unwanted matter beneath the teeth.

6.3.4. The combs should have a form and inclination such that the feet of passengers, leaving the escalator, will not stub against them. In any case the angle " β " shown in figure 2 should not exceed 50°.

6.3.5. The combs should be adjustable vertically. The sections of the combs should be easily replaceable.

6.3.6. (1) In the case of a foot (or other part of the body) being caught between the step and the comb a device should stop the escalator.

(2) The trapping of an object between step and comb should bring about the operation of the above device or break the comb teeth* before damage occurs to the other parts of the escalator.

* The maintenance personnel should of course replace the broken teeth as soon as possible.

7. Step drive

7.1. DRIVE BY CHAINS

7.1.1. The steps should be driven by at least two roller chains.

7.1.2. The factor of safety* of the chains should be at least 5.

7.1.3. The chains should be tensioned automatically by springs or by counterweights.

7.2. Other methods of driving may be adopted provided that they offer guarantees of safety and operation at least equal to those required in 7.1 above.

* The factor of safety is the ratio between the breaking strength of the chains and the static load to which they are subjected when the escalator carries a load calculated in accordance with clause 3.7.1.

8. Inclination of the escalator and guiding of steps

8.1. ANGLE OF INCLINATION AND POSITION OF STEPS

8.1.1. The angle of inclination of the escalator to the horizontal should not be in excess of 30° . However, for a vertical rise not exceeding 6 m and a contract speed not exceeding 50 cm/s the angle of inclination may be increased to a maximum of 35° .

8.1.2. The top surface of the steps in the area used by the passengers should be horizontal.

8.1.3. Figure 2 has been established when $v > 50$ cm/s.

8.1.4. (1) At each end of the escalator the passengers should have available an area of sufficient length, in which the steps travel in a substantially horizontal direction.

(2) The length λ of that area taken from the point "L" (fig. 2, 3 and 5) should be at least equal to:

(a) 40 cm if the contract speed of the escalator does not exceed 50 cm/s;

(b) 60 cm if the contract speed exceeds 50 cm/s.

(3) Within the area specified above, the vertical play between two consecutive steps should be less than 10 mm.

Exception: However for escalators with contract speed not exceeding 50 cm/s with a radius of the exposed step belt not less than 1.5 m, the play η may be increased to 35 mm.

8.2. GUIDING OF STEPS

8.2.1. The necessary provisions should be made to limit the displacement of the steps should a driving device break.

8.2.2. The guiding of the steps in the area of the combs should be very accurate to prevent the teeth of the comb touching the grooves in the steps.

9. Clearance between steps and between steps and balustrades

9.1. CLEARANCE BETWEEN STEPS

9.1.1. The horizontal clearance between two consecutive steps in any usable position measured at the top surface of the grooves should not exceed 5 mm.

9.2. CLEARANCE BETWEEN STEPS AND BALUSTRADES

9.2.1. The horizontal clearance between steps and balustrades should not exceed 5 mm on either side and 7 mm for the sum of the clearances at both sides.

9.3. CLEARANCE BETWEEN STEPS AND COMBS

9.3.1. The clearance "Q" indicated in figure 2 should not exceed 4 mm.

9.3.2. The clearance "R" indicated in figure 2 should not exceed 4 mm.

10. Machine

10.1. SPEED

10.1.1. The contract speed of the escalator should not exceed:

- (a) 75 cm/s for an escalator inclination not greater than 30°;
- (b) 50 cm/s for an inclination greater than 30°.

10.1.2. (1) For escalators that operate in the downward direction the speed measured in descent with a load calculated as in 3.7.1. should not exceed the contract speed by more than 5 per cent (see definitions).

(2) For escalators operating only in the upward direction the speed measured at no load should not exceed the contract speed by more than 5 per cent (see definitions).

10.2. DRIVE

10.2.1. When belts are used between the motor and the escalator they should be either vee belts or toothed belts. Their number should be equal to the minimum calculated number + 1, but never less than 3.

10.3. BRAKE

10.3.1. (1) The escalator should be provided with an automatic braking system that mechanically and progressively stops the escalator should the power supply fail, and holds it stationary.

(2) This recommendation should be observed whatever the load up to the ultimate value calculated in 3.7.1. and regardless of the direction of movement in the case of reversible escalators.

10.3.2. The normal lifting of the brake should be obtained by the action of a continuous flow of electric current. Braking should become effective immediately the brake circuit is opened.

10.3.3. It should be possible to lift the brake manually; such release should require permanent application of manual force.

10.4. PROTECTION AGAINST RISKS OF OVERSPEED IN THE CASE OF NON-ASYNCHRONOUS MOTORS

10.4.1. To prevent excessive overspeeding the escalator should be provided with a speed governor, the tripping of which should cause the escalator to stop automatically and in a progressive manner. The speed governor should trip at the very latest when the speed attains a value of 1.2 times the contract speed.

10.5. PROTECTION AGAINST RISKS FOLLOWING A BREAKAGE IN THE TRANSMISSION

10.5.1. When the coupling between the motor and the driving wheels is not by means of a shaft, gear wheels, or multiple chain on the same pinion, a device should cause the escalator to stop automatically and in a progressive manner:

- (a) at the very latest when the speed attains a value of 1.2 times the contract speed,
- (b) immediately on the accidental reversal of the direction of movement.

Note: The above provisions are made to prevent that breakage or failure of the transmission will result in:

- (a) dangerous overspeeding when the escalator operates in the downward direction,
- (b) a reversal of the direction of movement when the escalator operates in the upward direction.

10.5.2. This stopping may be effected by the operation of the brake if this acts directly on the shaft of the driving wheels.

10.5.3. Where not so arranged a special stopping device should be installed acting on the shaft of the driving wheels and satisfying the following requirements:

- (a) it should be capable of progressively stopping the escalator with full load in the direction of descent;
- (b) its operation should positively open the control supply.

It is not necessary that this device is electrically operated such as the brake mentioned in 10.3.

10.6. HAND WINDING DEVICE

10.6.1. If a hand winding device has been provided it should be readily accessible and safe to operate.

10.7. PROTECTION OF MACHINES

10.7.1. Near positions where maintenance work is carried out, keys and other similar projecting parts, journal ends as well as gears, chains and belts should be provided with appropriate protection.

11. Electrical installations and equipment

11.1. GENERAL

11.1.1. In view of their importance with regard to safety, electric wiring associated with escalators should be designed and executed with utmost care. The wiring should comply with the regulations ruling in the country where the escalator is installed.

11.1.2. Every precaution should be taken to prevent accidents which could result from accidental contact or from insulation faults to earth or between conductors.

11.2. PROTECTION OF MOTORS

11.2.1. The driving motors should be protected against overloads and short circuits.

11.2.2. Every provision should be made to prevent damage to equipment in the case of failure of a single phase of the electricity supply.

11.3. CONTACTORS AND RELAYS

11.3.1. In view of the fundamental part contactors and relays play with regard to safety this equipment should be selected with utmost care, and be of sound design and construction taking account of operating requirements.

11.4. VOLTAGE IN CONTROL CIRCUITS

11.4.1. The maximum voltage (rms) between conductors of control circuits should not exceed 250 V.

11.5. TRIPLE-POLE DISCONNECTION OF THE POWER SUPPLY LINE

11.5.1. The power supply line to the machine should be provided with a triple-pole main switch or circuit breaker, opening the supply to the machine in all phases simultaneously. This main switch should be so located that it can be operated immediately on opening the access door or trap door to the machine enclosure.

11.6. LIGHTING SUPPLY

11.6.1. The lighting supply and the supply of the socket outlets should be independent of the supply to the machine either by taking them from a separate supply or by connecting them to the main supply to the machine before the main switch of the escalator.

12. Starting and stopping

12.1. STARTING AND COMMISSIONING THE ESCALATOR

12.1.1. (1) Starting the escalator (or making it available for use when starting is automatic by a user passing a certain point) should be effected by one or more contacts accessible to authorised persons only (locked contacts for example). The person who operates this contact should be able to see the entire escalator, either directly or by television.

(2) For escalators automatically started by a passenger's approach the action of the contacts envisaged above should cause the escalator to start and run for a set time.

12.1.2. The provisions required in 12.1.1.(1) and (2) should apply in case of reversal of the direction of movement.

12.2. STOPPING DEVICES

12.2.1. All stopping devices should act by interrupting current and not by the completion of a circuit of a relay.

12.3. MANUAL STOP

12.3.1. Stop buttons (or other manually operated switches) should be easily accessible at the top and bottom landing of the escalator or in their near proximity and be protected against accidental operation.

12.3.2. The stop buttons or switches should operate by positive mechanical opening of contacts.

12.4. AUTOMATIC STOPPING

12.4.1. The escalator should stop automatically in the case of:

- (a) failure of the power supply,
- (b) failure of the control supply,
- (c) operation of the speed governor mentioned in 10.4.1.,
- (d) breaking or failure of the transmission in the cases mentioned in 10.5.,
- (e) unequal stretching of one of the step driving chains,

- (f) breakage of one of these chains,
- (g) (unintended) diminution of the distance between the driving wheels and the return wheels,
- (h) operation of the stopping device mentioned in 6.3.6. (1),
- (i) stopping of a succeeding escalator where an intermediate exit does not exist.

12.4.2. The escalator control may be arranged to stop the escalator automatically at a certain time after the last passenger has passed.

12.5. RESTARTING THE ESCALATOR

12.5.1. After a manual stop (see 12.3.) or an automatic stop other than the one mentioned in 12.4.2. above, recommissioning should only be possible by means of one of the contacts mentioned in 12.1.1. (1).

13. Notices, operating instructions and signals

13.1. PLATES, NOTICES AND OPERATING INSTRUCTIONS

13.1.1. All plates, notices and operating instructions should be untearable, of durable material, placed in a conspicuous position and written in perfectly legible characters in the language of the country where the escalator is installed (or in several languages if the national code requires this).

13.2. NEAR THE ENTRANCES OF THE ESCALATOR

13.2.1. Instructions, suitable to local conditions and preferably in the form of pictures should be displayed.

- Examples - small children should be carried or held by the hand,
- barefooted use of the escalator is prohibited,
 - umbrellas, perambulators, trolleys, dogs, parcels, etc. should not be placed on the steps,
 - do not slide feet along the balustrades or step risers.

13.2.2. The stop buttons or switches referred to in 12.3.1. should be coloured red and be marked with an inscription "stop".

13.2.3. The road traffic sign "no entry", of the type in force in the country where the escalator is installed, should be fixed to barriers or chains put up to prevent access to the escalator during maintenance and repair work. This also applies in the event of a breakdown unless use of the stationary escalator can be made without danger.

13.3. IN THE MACHINE ENCLOSURES

13.3.1. Operating instructions for hand winding the machine and indication of the direction of movement of the escalator should be fixed inside the machinery enclosure.

13.3.2. The stopping switch should be labelled "stop" and "start".

13.4. IN THE ENCLOSURES FOR THE GEARS FOR DRIVING AND RETURN

13.4.1. The stopping switch should be labelled "stop" and "start".

13.5. ON THE ACCESS DOORS THE ENCLOSURES FOR THE MACHINE, AND THE GEARS FOR DRIVING AND RETURN

If there is such a door a notice should be fixed indicating:

Escalator Machinery - Danger
Access prohibited to unauthorised persons

13.6. SPECIAL PROVISIONS FOR ESCALATORS THAT START AUTOMATICALLY

13.6.1. In the case of escalators that start automatically a clearly visible signal system, using the road traffic signals in force in the country where the escalator is installed should clearly indicate to the users if the escalator is available for use, and its direction of movement.

14. Maintenance and inspection of escalators

14.1. MAINTENANCE

Escalators should be regularly maintained by competent personnel.

14.2. INSPECTION

14.2.1. Escalators should be inspected before being brought into service and thereafter at periodic intervals.

14.2.2. These inspections, when not made by a public authority, should be made by an organisation or person licensed by the public authority (when there is an agreement to do so in the country concerned) and whenever possible independent of the manufacturer and the organisation responsible for maintenance.

14.3. REGISTER

14.3.1. Technical data of the escalator should be entered into a register which should also contain the electric wiring diagrams.

14.3.2. Dates and results of inspections as mentioned in 14.2. should be entered into the register.

14.3.3. This register should be kept by the organisation responsible for the maintenance.

14.3.4. A copy of the register or part of this document should be handed to the owner of the escalator on request.

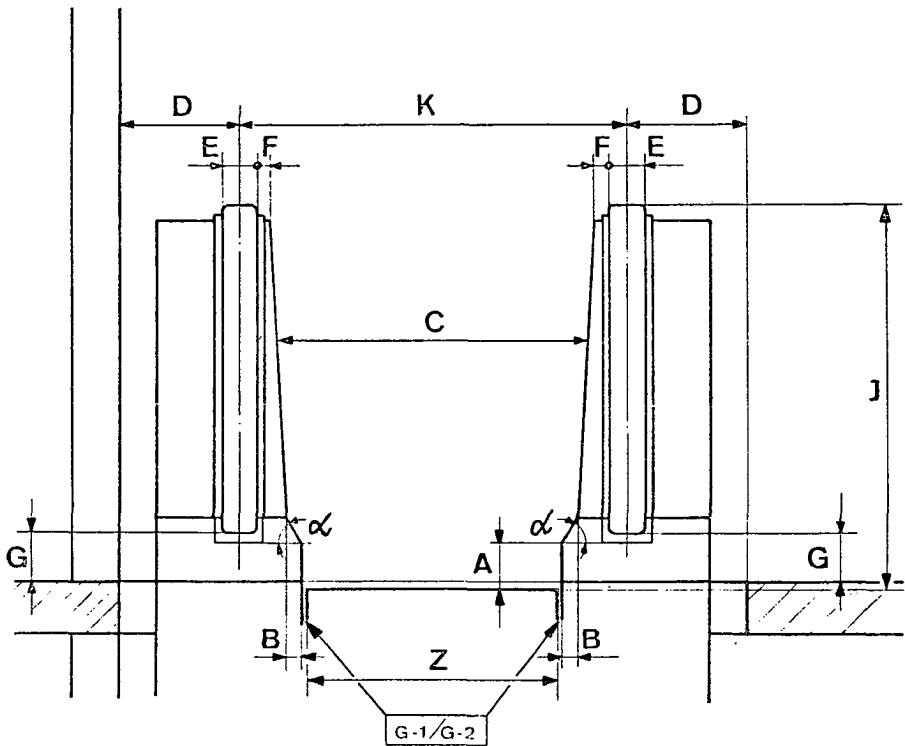

Fig. 1 - Balustrades and moving handrails

See paragraph

A	3.4.6. (2)	$A \geq 2 \text{ cm}$
α	3.4.6. (3)	$\alpha > 25^\circ$
B	3.4.6. (4)	$B < 12 \text{ cm}$ (if α less than 45°)
C	3.4.7.	$Z < C < (Z + 33 \text{ cm})$
D	3.6.5. Exception	$D \geq 50 \text{ cm}$
E	5.3.2.	$7 \text{ cm} \leq E \leq 10 \text{ cm}$
F	5.3.3.	$F \leq 5 \text{ cm}$
G	5.4.1.	$10 \text{ cm} \leq G \leq 25 \text{ cm}$
J	5.5.1.	$85 \text{ cm} \leq J \leq 1.10 \text{ m}$
K	5.6.1.	$K \leq (Z + 45 \text{ cm})$
Z	5.6.1. and 6.1.3	$40 \text{ cm} \leq Z \leq 1.10 \text{ m}$

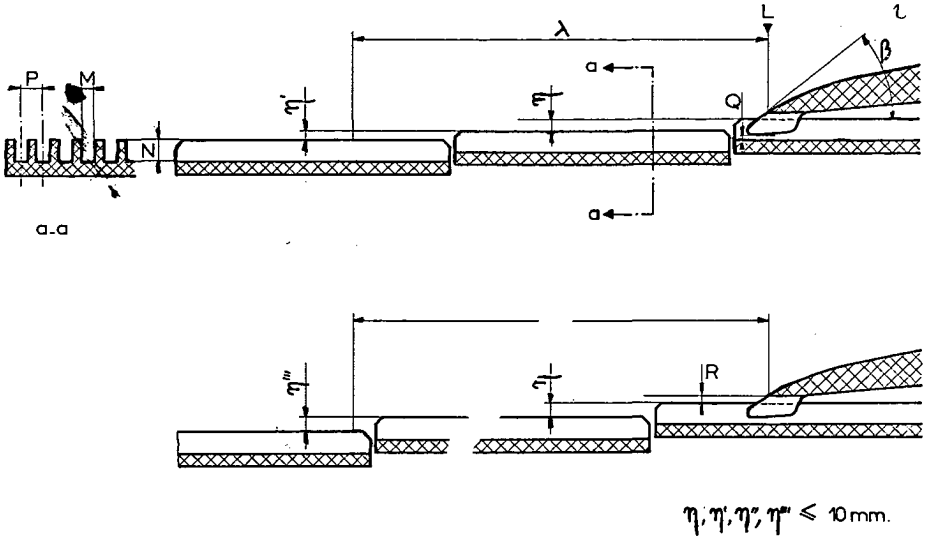

Fig. 2 - Teeth of comb and grooves of step

See paragraph

L	3.6.3. and 5.2.1.	root of the comb teeth
M	6.2.3. (1)	$M \leq 7 \text{ mm}$
N	6.2.3. (2)	$N \geq 10 \text{ mm}$
P	6.2.3. (3)	$P \leq 10 \text{ mm}$
β	6.3.4.	$\beta \leq 50^\circ$
η	8.1.3. (3)	$\eta \leq 10 \text{ mm}$ exception 8.1.3.
λ	8.1.3. (2)	$\lambda \geq 40 \text{ cm}$ if $v \leq 50 \text{ cm/s}$ $\lambda \geq 60 \text{ cm}$ if $v > 50 \text{ cm/s}$
Q	9.3.1.	$Q \leq 4 \text{ mm}$
R	9.3.2.	$R \leq 4 \text{ mm}$

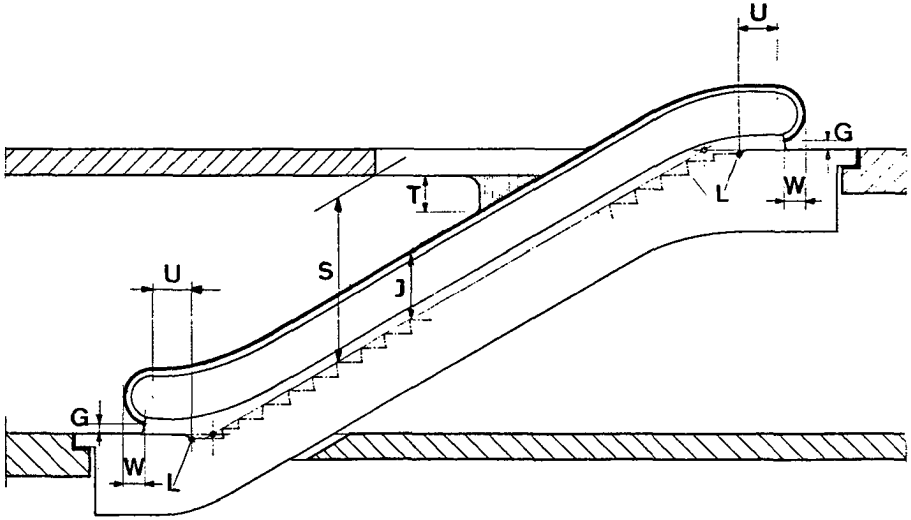

Fig. 3 - Side view of an escalator

See paragraph

L	3.6.3. and 5.2.1.	root of comb teeth
S	3.6.4.	$S \geq 2.10 \text{ m}$
T	3.6.5.	$T \geq 25 \text{ cm}$
U	5.2.1.	$U \geq 30 \text{ cm}$
G	5.4.1.	$10 \text{ cm} \leq G \leq 25 \text{ cm}$
W	5.4.2.	$W \geq 30 \text{ cm}$
J	5.5.1.	$85 \text{ cm} \leq J \leq 1.10 \text{ m}$

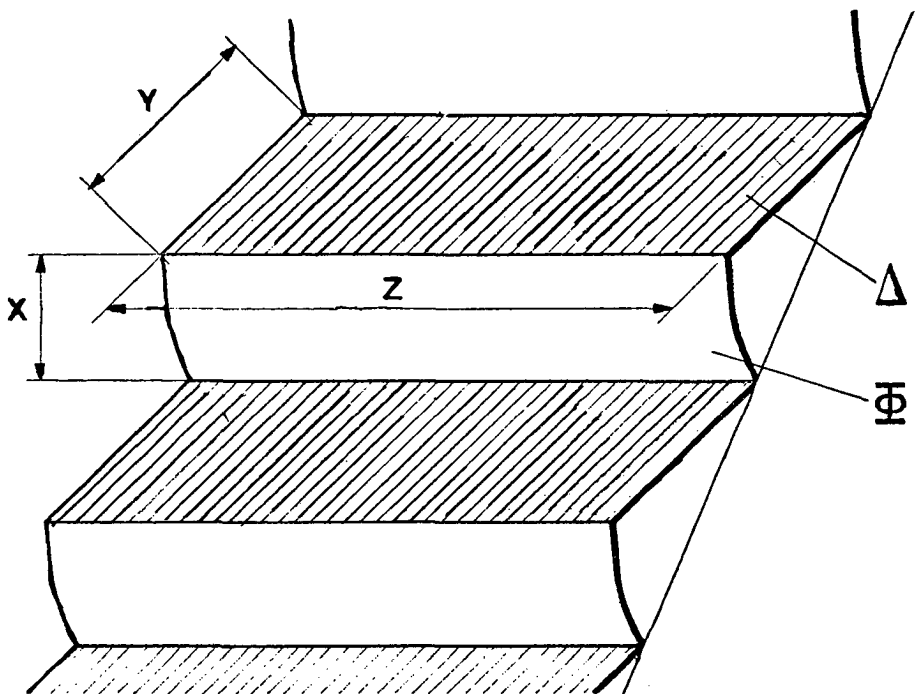

Fig. 4 - Steps

See paragraph

Δ	3.7.1.	surface of step
X	6.1.1.	$X \leq 24 \text{ cm}$
Y	6.1.2.	$Y \geq 38 \text{ cm}$
Z	6.1.3.	$40 \text{ cm} \leq Z \leq 1.10 \text{ m}$
Φ	6.2.4.	riser

Index

Access to enclosures of machines 4.2; 4.3.2; 13.5
Access to gears 4.1
Balustrades 2.0.1(a); 3.4; 9.2
Brake 10.3
Breakage in the transmission 10.5
Clearances:
 above steps 3.6.4
 between steps 9.1
 between steps and balustrades 9.2
 between steps and combs 9.3
Combs 2.0.1; 6.3; 9.3
Crossing points 3.6.5
Chairs (driving) 7.1
Chairs (safety factor) 7.1.2
Circulation under the escalator 3.5.1
Construction 3.7
Definitions 2
Electrical equipment 11
Enclosures for machines, associated equipment and gears 4.1;
 4.3; 13.3; 13.4; 13.5
Escalators (definition) 2.0.1
Exit 3.6.1
Fire protection 3.9
Handrails 2.0.1; 5
Hand winding device 10.6; 13.3.1
Inclination of balustrades 3.4.6
Inclination of the escalator 8.1
Inspection 14.2
Inspection doors 3.1.1; 3.2
Ladders 4.2.2
Lighting 3.8; 4.3.3; 11.6
Load 3.7.1; 6.2.1
Machines 2.0.1; 10
Maintenance and inspection 13.2.3; 14
Motors 11.2
Notices and instructions 13
Openings 3.1.1; 3.3
Operating instructions 13
Overspeeding 10.4; 10.5
Passenger handling capacity 3.6.2
Register 14.3
Repairs 13.2.3
Reversal of the direction of movement 10.5.1
Scope 1
Step drive 7; 10.2; 10.5.1
Step guiding 8.2
Step risers 6.2.4
Steps 2.0.1; 6
Stopping device 4.3.3; 12.2; 12.3; 12.4; 13.2.2; 13.3.2
Surrounds of the escalator 3.6
Sockets 4.3.3
Speed (contract) 2.0.1
Speed governor 2.0.1; 10.4.1
Starting 12.1; 12.5; 13.3.2
Trap doors 3.1.1; 3.2
Ventilation openings 3.1.1; 3.3
Voltage in control circuits 11.4

