

# Safety - Health and Working Conditions

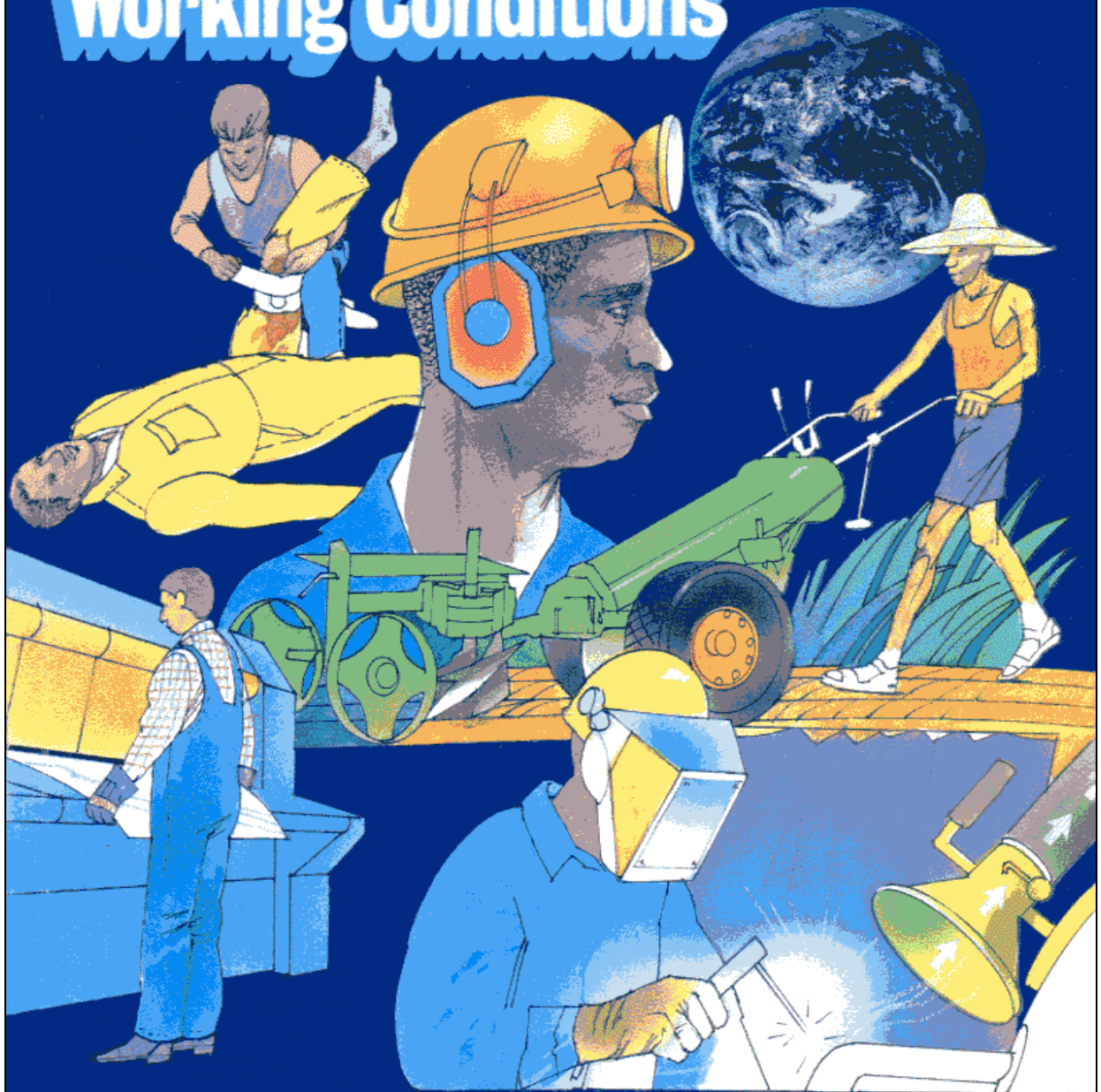

*Training Manual*

# **Safety-Health and Working Conditions**

**Photograph on cover: the Earth seen from Apollo 17, showing Africa and the Antarctic.**

First edition, first printing, 4 000 copies.

Educational material on Safety, Health and Working Conditions produced by the Joint Industrial Safety Council in Sweden in co-operation with the International Labour Office in Geneva and partly supported by the Swedish International Development Agency.

Copyright © 1987: Joint Industrial Safety Council, the working environment body for management and labour, Post Box 3208, S-103 64 Stockholm, Sweden. Phone (+ 468) 22 94 20.

Editor: Lennart Fridlund Drawings: Gyula Buváry,  
Mohammad Ali Translation: Struan Robertson  
Printed by: Tiba Tryck AB, Stockholm 1987 6436

ISBN 91-7522-115-2

# *PREFACE*

TODAY'S workplace is faced with accelerating changes in technology. Economic and social developments are also changing the daily life of workers. Despite the progress achieved, the safety, health and conditions of work of many workers remain arduous or give rise to new problems as a result of these changes.

Can the conditions in which men and women work in different countries be improved now so as to meet the needs and the legitimate expectations of workers? This question is of prime importance to governments, employers and workers throughout the world.

This manual is the result of concerted efforts of the International Labour Office and the Swedish Joint Industrial Safety Council. It is prepared as a tool for training people directly concerned with workplace improvements. It is designed particularly for use in developing countries.

The ILO, created in 1919, has endeavoured to set international standards for workers' protection and to provide practical information about the world's labour problems. Many of the ILO Conventions and Recommendations thus concern safety, health and conditions of work. For example, Convention No. 1 (1919), which provided working hours should not exceed eight hours a day and 48 hours a week, has had an enormous influence on national law and practice. Recommendation No. 5 (1919) advocated the establishment of government services to safeguard the health of workers. Other examples include Convention No. 14 (1921) on weekly rest in industry, Recommendation No. 102 (1956) on welfare facilities, the Minimum Age Convention No. 138 (1973) and a series of Conventions and Recommendations on safety, health and working conditions. Recent examples are Convention No. 155 and Recommendation No. 164 (1981) on occupational safety and health.

A new impetus towards the improvement of conditions of work and occupational safety and health was given by the launching in 1976 of the International Programme for the Improvement of Safety, Health and Working Conditions (PIACT). The programme had its origin in the Report of the Director-General to the 60th Session of the International Labour Conference on "Making Work More Human". The programme has a broad scope, including safety and health at the workplace, hours of work and other problems of working time, work organisation and content, choice of technology and services and facilities for workers' welfare.

The need for full participation by employers and workers in carrying out improvements has been emphasised in this new approach.

In Sweden in 1974, the Joint Industrial Safety Council produced educational material designed to acquaint all Swedish workers with knowledge of working environment issues. This material consisted of a book about ways of making the safety, health and working conditions better. It was designed to be used by workers and others getting together in small groups and discussing their own situations and ways to improve them. This effort, inspired by agreements between Swedish employers and unions and reinforced by Swedish law, proved very successful.

In 1978, the Swedish Joint Industrial Safety Council combined with the International Metal Workers' Federation to produce similar material in English, Spanish and Portuguese for use by workers in developing countries.

In 1982, the International Labour Office in co-operation with the Swedish Joint Industrial Safety Council adapted the material and re-designed it in line with the PIACT's scope. After its experimental use in training workshops in different parts of the world, the material is now available for widespread use in training courses for managers, supervisors, workers, safety representatives and others in all kinds of industries in developing countries.

JOINT INDUSTRIAL SAFETY COUNCIL  
STOCKHOLM

INTERNATIONAL LABOUR OFFICE  
GENEVA



# TABLE OF CONTENTS

<b>INTRODUCTION</b> .....	<b>6</b>
<b>1. SAFETY, HEALTH AND TECHNICAL EQUIPMENT</b> .....	<b>9</b>
Causes of accidents .....	9
Risks in all workplaces .....	9
First aid .....	10
Technical equipment .....	16
Lifting equipment .....	17
Vehicles .....	19
Safety requirements for machinery .....	20
Tools and equipment .....	23
Electricity and its risks .....	23
Welding .....	26
Boilers and pressure vessels .....	27
Good housekeeping .....	27
<b>USEFUL HINTS</b> .....	<b>29</b>
<b>2. WORKPLACE CLIMATE LIGHTING AND NOISE</b> .....	<b>31</b>
Working conditions influences work performance .....	31
The workplace climate .....	32
Measuring heat stress .....	32
Protection against heat .....	35
Protection against cold .....	36
Lighting .....	38
General and local lighting .....	41
Effects of noise .....	42
Vibrations combined with noise .....	46
Decibels .....	46
Methods of noise control .....	47
Hearing protectors .....	50
<b>USEFUL HINTS</b> .....	<b>52</b>
<b>3. CHEMICAL RISKS TO HEALTH</b> .....	<b>53</b>
Inspection and control of chemicals .....	53
Chemicals and their risks .....	53
A. Atmospheric pollution .....	54
B. Gases .....	57
C. Liquids and vapours .....	58
D. Genetic effects .....	59
E. Metals and other hazardous chemicals .....	60
F. Occupational skin diseases .....	60
Principles of technical measures .....	63
Ventilation .....	64
Personal protection equipment .....	65
<b>USEFUL HINTS</b> .....	<b>68</b>
<b>4. FITTING WORK TO PEOPLE: ERGONOMICS</b> .....	<b>69</b>
Changing technology and people .....	69
Working position – standing .....	70
Working position – sitting .....	72
Strenuous work .....	73
Design of controls and tools .....	75
Signal displays and panels .....	76
<b>USEFUL HINTS</b> .....	<b>77</b>
<b>5. WORK ORGANISATION AND WORKING TIME</b> .....	<b>79</b>
Better quality of working life .....	80
Work organisation and job content .....	80
Ways to improve work organisation .....	81
Hours of work .....	84
Time for rest and leisure .....	85
Shift work .....	87
New patterns in working time .....	89
<b>USEFUL HINTS</b> .....	<b>90</b>
<b>6. DAILY ACTIVITY FOR SAFETY, HEALTH AND WELL-BEING</b> .....	<b>91</b>
Better safety, health and working conditions improve productivity .....	92
Objectives for safety, health and well-being at work .....	92
Routines for workplace inspections .....	92
Health services .....	95
Safety and hygiene practices .....	97
Welfare facilities .....	98
Efforts towards safety, health and working conditions .....	101
Laws and regulations – national and international .....	104
<b>USEFUL HINTS</b> .....	<b>106</b>

*Checklist for improving safety, health and working conditions (separate)*

*Discussion Leader's Guide (separate)*

# INTRODUCTION

*“This training manual is designed to help you start discussing safety, health and working conditions of all the workers at your workplace.”*

## Working in industry

Many of us have looked for and found a job in industry in the hope of getting secure employment. Another equally important reason is to develop new skills with good career prospects. We expect the job to be rewarding and free from harmful effects. We also want it to give us stimulation and personal development.

However, many of us feel that the work we do needs to be made more human. We may fear that our job is not safe and that the workplace conditions cause damage to our life, our health, our dignity and our professional skill. We often feel that our cultural values and self-respect must be safeguarded in a better way on the job.

What steps are necessary to *make work more human* and rewarding, to give more stimulation and personal development? Many countries in Asia, Africa, Latin America and other parts of the world have taken action in legislation and national development plans. Such action will not be fruitful unless the real initiative is taken at the workplace.

Through the use of this manual, *Safety, Health and Working Conditions*, we will discuss the necessary to make work more human. The manual has been produced for the joint use of industrial workers, supervisors and concerned people all around the world.

This training course covers:

### 1. Reading about:

- Training for safety, health and working conditions.
- People, safety, health and technical equipment.
- Workplace climate, lighting and noise.
- Chemical risks to health.
- Ergonomics: fitting work to man.
- Work organisation and working time.
- Daily activity for safety, health and wellbeing.

The instructors will present lectures as introductions to different sections, but you should read and understand all the sections of this manual.

### 2. Work with the discussion topics:

Reading the manual will help you discuss safety, health and working conditions in your country. Special boxes have been provided containing discussion topics which relate to the text preceding each box.

The “Discussion Topics” are designed to enable a comparison of the information given in the manual with your experience in your own country. We would like to hear what you think and what you have experienced. This training is built around you and your situation!

*It is important that the training you are about to start takes place in as pleasant and friendly an atmosphere as possible.*



*Run the courses in well-lit premises that are screened off from noise. An overhead projector, a blackboard and chalk and a flipblock are useful to have. It is an advantage to be able to darken the room to use a slide projector or video equipment. Some smaller rooms should be available for study and group work.*

## *Learning method*

Throughout the course, work in small groups and discuss the topics contained in the manual. These topics are linked to the lectures based on the manual. The “Discussion Topics” and the group work are important in getting everybody involved in the discussion. The discussion should be based on the actual conditions in each participant’s own workplace and within the country. The following is a list of some of the topics you will be thinking about and discussing:

- How* is our industry growing?
- What* changes do we expect from new technologies?
- Why* do injuries and fatal accidents occur at workplaces?
- Why* are there often no safety guards for machines?
- Why* is the workplace too hot and too noisy?
- What* chemicals at my workplace put my health at risk?
- What* job characteristics are important for assuring a feeling of wellbeing at work?
- How* can our job quality improve?
- What* national work-related laws and regulations exist and how do they apply?

- How* can the existing safety, health and working conditions be improved to *make work more human*?
- Develop an *action* programme for your own workplace.

It is important that all the participants agree on the use of the available course for group discussions. Group learning is a well tried and proven study technique. Working with a manual and discussing it in a group is the best method of learning with this text.

The participants in the study groups will decide how the course will proceed using the manual. If you think a certain point needs more discussion you should propose it.

## *Discussion*

- Have a look through this manual and acquaint yourselves with the contents!
- What do you think are the most important questions that should be discussed during the group work sessions?





# SAFETY, HEALTH AND TECHNICAL EQUIPMENT

*“People become injured, disabled and are killed at their workplaces due to industrial accidents. What can we do to prevent industrial accidents from occurring?”*

## Causes of accidents

This accident is in many ways “typical”. The worker was working on a ladder, and fell suddenly. There are several basic factors behind accidents of this kind. Through accident investigation we can find out why accidents happen and how they can be prevented in the future.

As the starting point for any accident investigation, we must examine how the work procedure deviated from the correct routine. Factors causing such deviation include elements such as broken or malfunctioning machinery, incorrect working materials, incorrect work procedures, blocked aisles or passages, and liquids spilled on floors.

**One of the most common causes of accidents is falling from ladders or work platforms, often causing serious injury. We must learn more about the many and varied causes of accidents. For example, ladders seldom fall over on their own.**

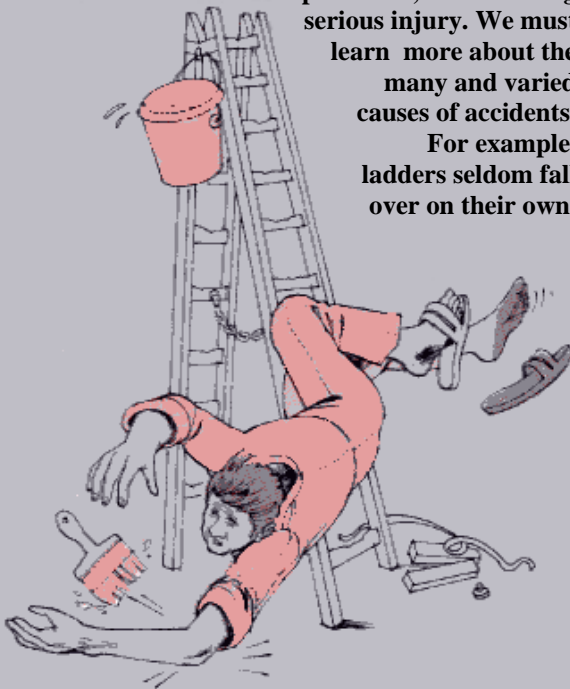

## Risks in all workplaces

There are risks in all workplaces. Safety is possible only by knowing these risks and properly guarding ourselves until the risks have been eliminated.

Technological progress is constantly taking place and while it often brings improvements in both efficiency and safety at work, it also can create new risks.

In this chapter we will discuss:

- causes of accidents
- first aid
- technical equipment
- lifting equipment
- vehicles
- machinery
- tools and equipment
- electricity and its risks
- welding
- housekeeping.

Useful hints about these points are given at the end of the chapter.

## Discussion

- Which risks mentioned in the previous pages are particularly high?
- What steps are taken to inform workers about particularly high risks?
- Do you think that workers have sufficient knowledge about particularly high risks?

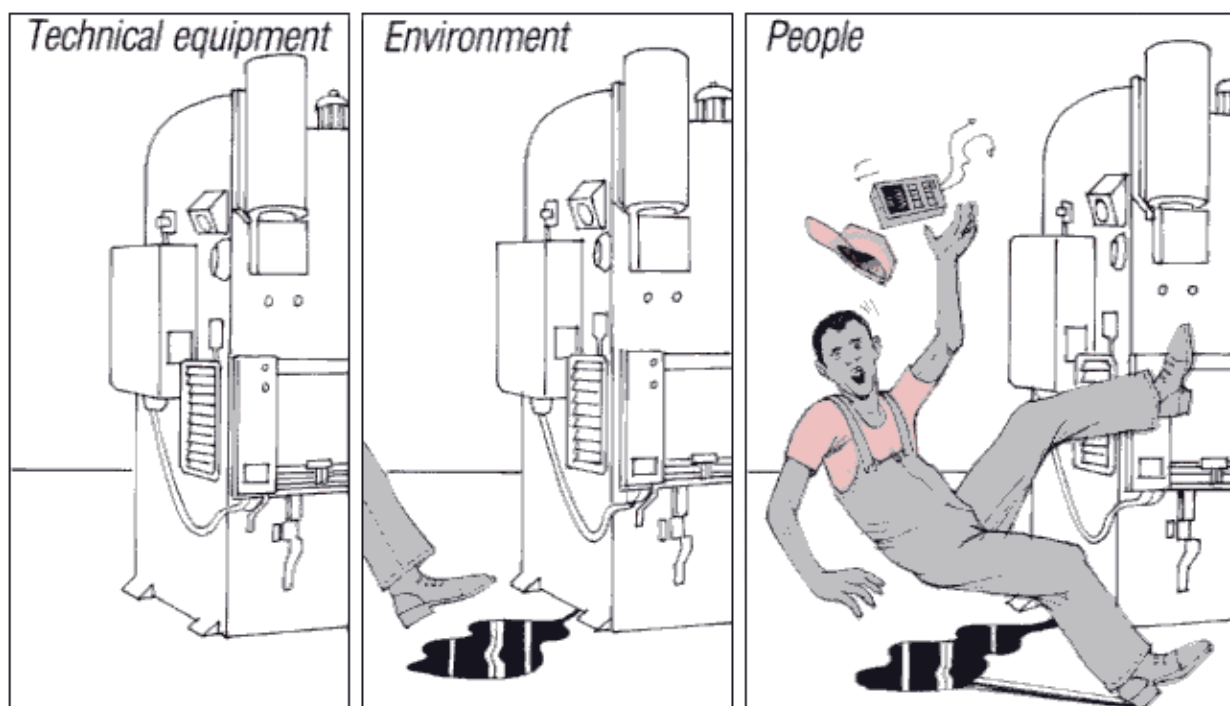

*Accidents cause both human suffering and considerable expense in loss of production and material damage.*

### Three main causes

In order to carry out an effective investigation and prevent accidents, we have to know why the various deviations in work procedure occurred. The three main contributory factors are:

*Technical equipment.* Examples: lack of equipment or faulty design leading to a sequence of unexpected events which finally result in an accident.

*The working conditions* can influence us indirectly thereby causing accidents. Such factors include:

- disorder at the workplace
- noise
- temperature
- ventilation
- lighting.

*People.* Your own performance can increase the risks of having an accident. Consequently all work should be planned from the point of view of the worker. The employer has the primary responsibility for the planning and layout of the workplace. Important factors include:

- Job experience.* It is the first stages of a new job or a new procedure that are usually the most critical. The same applies when a person changes jobs.
- Information* and instructions on the working methods and risks involved.

- Age.* Older people are more easily injured e.g. when falling. In general, eyesight and hearing decline with age.

These are just a few of the factors which can contribute to causing industrial accidents.

### First aid

First aid equipment and material should be readily available for treating industrial injuries or sickness at all workplaces. Such equipment includes a first aid kit and a stretcher with blankets. A person with first aid training should always be on the premises.

In the event of an accident, you should act in the following way:

- prevent more people from being injured
- call the instructor or supervisor, or the person responsible for first aid treatment. Call an ambulance if necessary.
- aid the injured person.

In the case of a serious accident, you should observe the following procedures in giving first aid to an injured person:



*The task of the workplace “first aider” is to attend to the victim of an accident, or to help when someone suddenly falls ill. Action taken in the first minutes is often crucial when saving life and limiting the extent of the injury. Everybody at the workplace must know who the trained first aiders are and where they can be found. He/she is also responsible for making sure that the first aid box is complete and contains the right equipment.*

## 1. Check breathing

Check quickly that air is passing in and out through the nose or mouth of the injured person.

If a person is unconscious and lying on his back, he can suffocate because the tongue can slip back into the throat and block the respiratory tract.

An unconscious person should therefore be placed immediately on his side, face down. Care must be taken if there is any possibility of a neck injury.

## 2. Respiratory failure – artificial respiration

If the person has simply collapsed, support the back of the neck with one hand, and place the other hand on the forehead. Bend the injured person’s head as far back as you can. Pinch his (her) nose and start blowing air in through his (her) mouth.

If the person has possibly injured his or her neck, grasp the chin and pull it away from the neck without moving the neck.

Keep an eye on the injured person’s chest and when it rises you know that the lungs have started taking in air.

Repeat the blowing action once every five seconds. Continue with artificial respiration until the injured person starts breathing or medical personnel take over.

If you are trained in cardiopulmonary resuscitation, begin cardiopulmonary resuscitation if indicated.



*If no breath can be felt from the mouth or nose, and there is no movement of the chest, then the victim has stopped breathing. Call for help. Next, open the air passages by leaning the head backwards. Begin artificial respiration. The first four breaths should be rapid, then continue at a normal rate. Check the results by looking for chest movements.*

## 3. Stemming heavy bleeding

If the injured person is bleeding, try to stop the bleeding by using direct pressure on the wound and by placing the injured limb in a raised position.

In most cases this is all that is required to stem the flow of blood.

The injured person should lie with his/her feet up, except in cases of head or chest injury or difficulty in breathing.

## 4. Preventing shock

In the case of serious accidents, e.g. deep wounds accompanied by heavy loss of blood, bad jamming accidents, injuries to the chest or stomach leading to internal bleeding and severe burns, etc., there is always a high risk that the injury will lead to shock.

Severe accident shock can be fatal. But it can also be prevented!

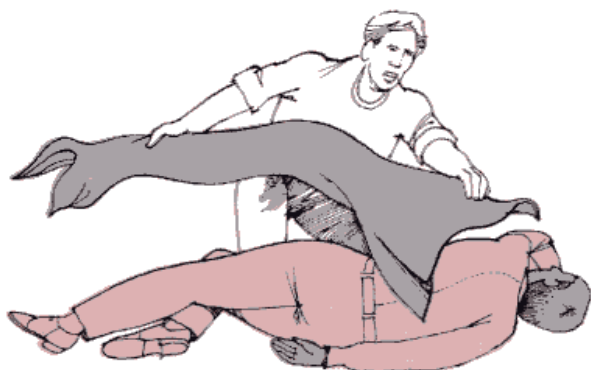

**First check that the victim is breathing without help. Next, prevent shock by laying the injured person face down on one side. Loosen any tight clothing. Place a blanket under the injured person and cover him/her up. Protect the injured person from direct sunlight. Do not give him/ her anything to drink unless on a doctor's orders. Moisten the injured person's lips and tongue if asked to.**

Examples of measures to prevent shock:

- *free respiration*: always place an unconscious person on his/her side in a slightly forward leaning position. Care should be taken to protect an injured neck.
- *stop bleeding*: direct pressure on the wound with the injured limb in a raised position.
- *rest*: the injured person should lie with the feet and legs raised above the level of the head. Warmth helps, so cover him with a blanket. It is important to maintain body temperature.

## 5. Wounds, cuts, abrasions

The most common injury resulting from an accident is a cut or abrasion.

If cuts and abrasions are superficial, first stem the bleeding then clean them carefully and thoroughly with soap and water. After cleaning, cover them with a bandage.

The person applying first aid should be particularly careful about first washing his/her hands. You should never stick your fingers into an open wound and never touch that part of the bandage which will be lying directly on top of the wound.

Serious cuts and wounds should always be treated by a doctor. In such cases first aid help is restricted to the application of a dressing and bandage.

Abrasions may appear relatively light and insignificant, however, it is often more of an infection risk than an open wound.

All deeper cuts and abrasions which are the result of accidents occurring while working outside should be treated by a doctor to avoid tetanus (lock-jaw).

If an old wound or sore shows signs of being infected (swelling, discolouring or pain), it should be treated by competent medical personnel.

## 6. Burns

If a person's clothing has caught fire, the best way of quenching the flame is to roll the person on the floor or in a blanket. After extinguishing the flames make sure the person is breathing, cool the burn with water, cover the burn, and make sure that the victim gets to a hospital as quickly as possible.

Do not, under any circumstances, try to remove the victim's clothes.

If the area of the burn is larger than the palm of your hand, or the victim has facial burns, you can place a protective bandage over the injury. The victim must be taken to a hospital or doctor as quickly as possible after such preliminary measures.

In the case of more serious burns, it is very likely that the victim will suffer from shock. You should always be prepared to take the necessary measures to prevent severe shock.

If in the case of a burn smaller than the size of your palm, start treating the injury by cooling the burn. You can start immediately by rinsing the burn under running water. Or use the distilled water in the first aid box.

Never use flour, butter, cream, alcohol, iodine or such like substances on a burn! Never pierce a blister on a burn.

### Points to remember!

- All extensive wounds, cuts, abrasions and burns should be treated by a doctor or a nurse!

## 7. Injuries from working with corrosives

If anyone spills acid or alkali on the skin, you should rinse it off as quickly as possible with water unless otherwise indicated.

The injuries should then be treated in the same way as burns. Injuries from corrosive liquids are often much worse than they appear. For this reason the injuries, no matter how insignificant they may appear, should be treated by a doctor.

## 8. Eye injuries

The greatest possible care should be taken in the case of injuries to the eye or the area surrounding it.

“Dirt in the eye” is one of the most common eye complaints. If you get a mote in your eye, and it is near the surface, you can rinse it out or very carefully wipe it away with a damp swab of cotton or the corner of a clean handkerchief.

### Points to remember!

- If the object has become wedged in the eye it should be removed by a doctor.

Alkali or acid in the eye can cause intense pain. Because of the risk of the corrosives attacking the eye you should always rinse the eye immediately with water for at least 10 minutes. After rinsing you should have a doctor look at the injury.

*Hazardous chemicals, e.g. acids and lye, can rapidly produce serious burns. If these liquids are splashed in your eyes or on your body they must be rinsed off within a few seconds. Emergency showers and eye showers must be located close to the workplace. There must be free access to this equipment, which must be checked regularly to see that it is in working order.*

*Prevent the abovementioned risks by enclosing the work process. Use personal safety equipment such as visors, gloves and aprons.*



## 9. Injuries from electricity

Electric shocks affects the heart and can rapidly be fatal. Additional injuries could occur if the victim, when shocked, should fall from a scaffolding, ladder or any elevated place.

If the eye is exposed to the brilliant light from an electric arc, in welding work for example, it can become inflamed and irritated. The best thing to do in such a case is to get in touch with a doctor as soon as possible.

### Discussion

- Describe the necessary first aid facilities.
- What kit?
- Has anyone in your working group been trained in first-aid?
- What sort of skills would you expect such a person to have?
- Describe the most important arrangements for dealing with a serious accident.



**Points to remember!**

- Grabbing hold of a person injured by touching an electrical unit can be fatal.

Once the injured person has been pulled away from the live current, cardiopulmonary resuscitation should be applied if needed. Don't waste time moving the injured person to a sick bay or another spot.

As a rule, do not treat any electrical burn.

## 10. Broken limbs, sprains, dislocations

In cases where a fractured limb is suspected, the injured person should have his limb immobilised to prevent the break from getting worse and to alleviate the pain. Use a splint, a couple of sticks or even a rolled up newspaper, place the support on the outside of the clothing and secure it with a bandage. The splint or support should be long enough to cover the joints above and below the break in the bone. To avoid unnecessary pressure on the break, wadding can be inserted between the splint and the limb.

When there is an open wound on the broken limb, use a dressing to cover the wound before applying the splint.

*In the case of a broken arm or leg, do not make the injury worse by trying to straighten the broken limb. This picture shows a suitable way of moving a person with a broken leg. The leg is supported with rolled-up blankets on both sides to minimize movement at the break. All workplaces and companies must have plans and organization for rapid transportation to a suitable hospital and treatment of all injuries that are likely to occur.*

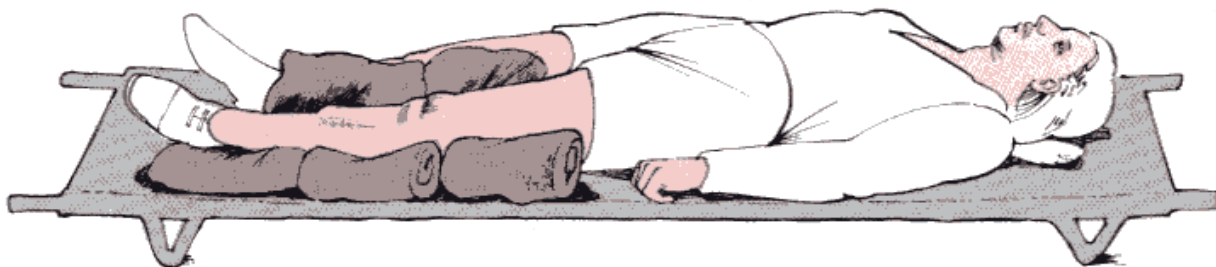

## 12. Injuries to the stomach

If an injury to the stomach is caused by a blow, being run over, or something falling on the person, etc., he or she should be taken to a hospital immediately.

Do not give the injured person anything to eat or drink.

Open wounds should be covered with a clean, wet bandage. Care must be taken in transporting the injured person to the hospital.

## 11. Injuries to the skull and spine

Blows to the skull can lead to unconsciousness (concussion) and spine injury.

If the person is breathing and conscious, do not allow him to move unless he needs to move to clear his air passages. In that case, taking care not to injure the spine, place him slightly on his/her side with the face down. In this position you can prevent blood running into the respiratory tract from any wounds in the mouth or throat. Never put wads in the nose of the injured person to prevent bleeding. When blood is running out of the ears, do not try to rinse it away. If an injured person has lost consciousness and is lying with his/her jaws locked tightly together, do not try to force them open.

**Points to remember!**

- An unconscious person is completely defenceless. Handle him (her) with the utmost care.

Never try to give an unconscious person something to drink; it can run into the respiratory tract and lungs and cause suffocation.

When you suspect a break in the spine or pelvis, the injured person should only be moved by trained personnel.

## 13. Lifting a person

When the injured person has to be carried to a safe place while waiting for an ambulance, the most comfortable way of *lifting* him (her) is *by using a stretcher or a big blanket*.

In order to rescue an injured person quickly from an exposed place, in the case of danger from fire, a good method is by dragging the person by the clothes.

*If you are alone and must rapidly move an injured work mate from a dangerous area, the following lift is a simple and good method to use.*



### Points to remember!

- Basic rules for dealing with an accident: Prevent more people being injured. Aid the injured person.

### Discussion

- What facilities are there in your workplace to deal with accidental eye or skin injuries?
- Has anyone received an electric shock in your workplace? If so, why was this?
- What facilities are necessary to treat injured persons aside from the first aid kit?
- Can you remember any accidents where someone needed to be lifted and carried away? Do you think everyone should be trained to lift an injured person?
- Have any measures been taken to prevent a recurrence of these kinds of accidents?

## Investigation

Summon immediately:

- someone with medical knowledge
- an ambulance or other vehicle to take the injured person to a hospital or a doctor if required.
- inform the management and the union safety representative
- determine the extent of the injury.

Cordon off the site of the accident and do not touch anything until the accident investigation has been completed.

Once the immediate steps described above have been taken, the accident should be investigated as quickly as possible, to establish the cause, not to lay blame.

The following points should be covered by such an investigation:

- a report on how the injury occurred (this should be obtained from the injured person, the co-worker or the supervisor)
- a list of the names of the people who witnessed the accident
- objects, materials etc. that were involved in or related to the accidents should be left untouched
- a simple drawing or a photograph of the site of the accident.

### Discussion

- What is the procedure for reporting an accident?
- How do you decide whether or not it is serious enough to report?
- What happens after an accident: is there an established routine for an accident investigation?
- Devise a short list of instructions for someone carrying out an accident investigation.



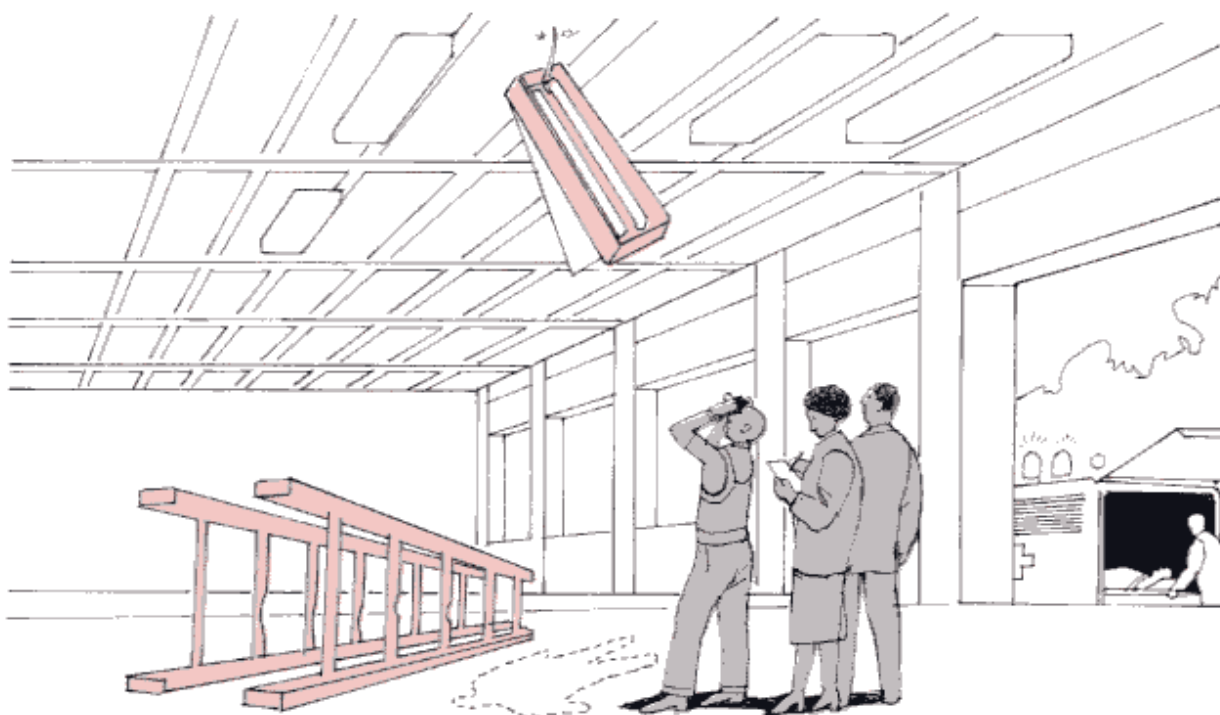

**Accidents and incidents must be investigated immediately. There must be clearly-established routines for the investigation, for who is responsible and who is to be informed. Always demand the introduction of measures to prevent similar accidents and incidents. NOTE! Prevent “cleaning up” and the removal of evidence.**

## Improved internal information

For improving occupational health and safety, it is important that accident investigations are carried out, recorded and evaluated for the prevention of further accidents.

Interested parties should discuss accidents to obtain a comprehensive picture of where the risks lie. Keep the records of these accidents and the discussion results. In this way the number of industrial injuries, their gravity and the types of accident usually associated with different types of machinery, equipment, substances, etc., for each category or group of workers can be determined.

### Discussion

- Would you expect inexperienced workers to be more safe or less safe than experienced workers?
- Are there procedures for making sure that new workers understand the risks?
- How would you make sure that they take notice of these warnings?

## Technical equipment

### LAYOUT- MATERIALS FLOW

Working conditions are constantly changing. New jobs, products, materials, tools and working methods are being introduced all the time.

These changes mean that our experience and the standards of safety we have built up in the past must be reviewed and brought up to date. However, gaps in our knowledge are not the only cause of industrial accidents. Faulty technical equipment is another major cause.

### A basic rule is that:

machinery and other technical equipment should be constructed, placed and used in such a way that they do not constitute a risk to health or cause accidents.

This means that machinery and equipment should be safe during all operating conditions and have effective safety guards at all dangerous points. If possible these guards should be an integrated part of the machinery so that the worker/operator is not tempted to remove them.

The path of the materials through the workplace constitutes a risk in the working environment. The layout of the manufacturing process

should be planned with as little risk of accidents as possible. "Layout" in this case means:

- the way different sections and processes are arranged in relationship to each other
- the arrangement of machinery and equipment within each work area.

**Points to remember!**

- Safety guards are essential parts of the machines. Working without necessary guards or removing them is dangerous.

Bottle-necks in the flow of materials cause work to become irregular and can thus increase the risk of accidents.

Operations which generate noise and vibrations should be separated from the rest of the manufacturing process. Additionally, the facility should be designed so that it functions well under special conditions, such as an abnormally high work load over a short period of time.

**Discussion**

- Can you list the safety guards on machines?
  - Can you think of any machines or processes which could do with better guarding?
- 

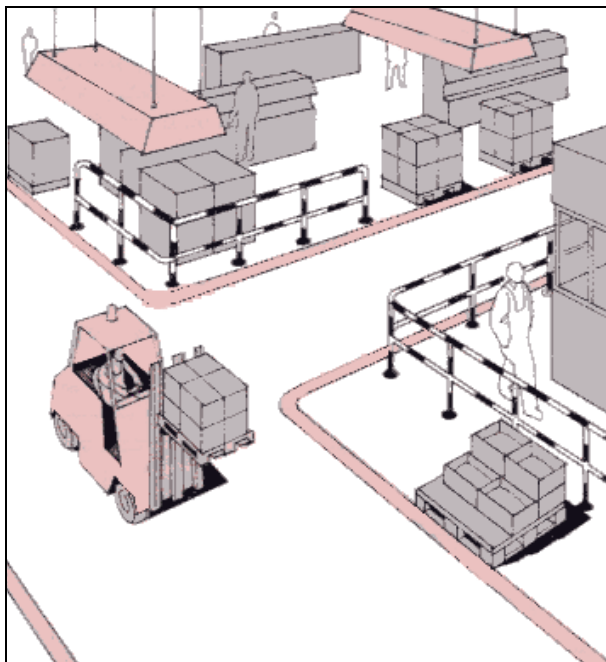

**Transport routes/aisles**

Overall planning of safe routes and aisles based on simplicity and easy understanding is the key to a safe workplace.

Many accidents happen while materials or goods are being transported around the workplace.

Therefore, the vehicles and equipment used inside the premises should be included in inspections.

Suitable access routes or aisles are required for access to mechanical equipment. Access to hoists and overhead cranes for service or repair work is also essential.

Safe storage and parking areas should be provided.

Emergency exits should be kept clear of all materials and equipment.

Access routes/aisles which are safe and rational should:

- be planned so that there is no danger of vehicle collision
- be positioned a safe distance from fixed workplaces
- have adequate lighting on stairs and ramps
- be clear of obstacles
- have pedestrians at a safe distance from vehicles
- have lines or markings which clearly show where they lead to
- be wide enough for traffic
- have handrails on the stairs if there are more than three steps
- have a guard barrier where there is a risk of falling
- be adapted for handicapped or disabled persons.

**Discussion**

- What are the safety arrangements with regard to the handling and transportation of materials?
  - What improvements would you like to see made about transport routes?
- 

**Lifting equipment**

**LIFTING APPLIANCES AND LIFTING TACKLE**

Lifting equipment should be designed so that it is safe to use under all conceivable operating conditions. The equipment should have the necessary safety devices, be well maintained, and should be inspected and checked at regular intervals.

Lifting equipment consists principally of:

- lifts (lift cages, platforms, buckets)
- lifting appliances (cranes, hoists, pulley blocks or other devices with hooks)
- lifting tackle (chains, slings, hooks, fork lifts, clamps, skips and similar equipment).

Lifting equipment must not be overloaded. If certain parts are stressed beyond rated capacities, vital parts may become worn and finally break. This wear may not be easily detected. Accident inspections frequently reveal defective equipment.

Lifting operations involving lifting appliances and tackle always put the worker at risk. The most common accidents are:

- pinching/crushing injuries when attaching or removing the lifting tackle and the load
- injuries involving pinching/crushing when lowering the load onto the ground or the floor
- injuries resulting from break or chain/rope failure
- injuries caused by falling objects, e.g. when part or all of the load becomes detached
- crane failure due to overloading.

Workers engaged in lifting with cranes should be supplied with appropriate protective equipment including helmets, footwear and gloves.

Periodic inspection with established routines must be carried out at prescribed intervals. These can cover e.g. the crane's structural soundness and anchorage, tests to determine the strength of the chains/ropes, and lubrication and adjustment of the brakes.

Critical points for inspection and control are:

- overload cut-out for large cranes
- limit switches for lifting gear and driving units (prevents a load coming into contact with and displacing any object, or being itself displaced)
- brakes for lifting gear steering controls
- hooks designed so that the ring or sling cannot slip out. (Open hooks should be banned.)

## Using lifting cranes and overhead travelling cranes

At workplaces such as shipyards, building sites and in the steel industry, cranes and overhead travelling cranes are used by different categories of workers. Often they do not know how the load should be stacked and slung.

Mechanical lifting outdoors may be made more difficult by the wind.

It is important that work involving lifting equipment is properly co-ordinated with the rest of the work.

### Points to remember!

- Always be on the look-out for falling objects. A crane operating above the heads of other workers always involves a risk.

### SIGNAL CHART

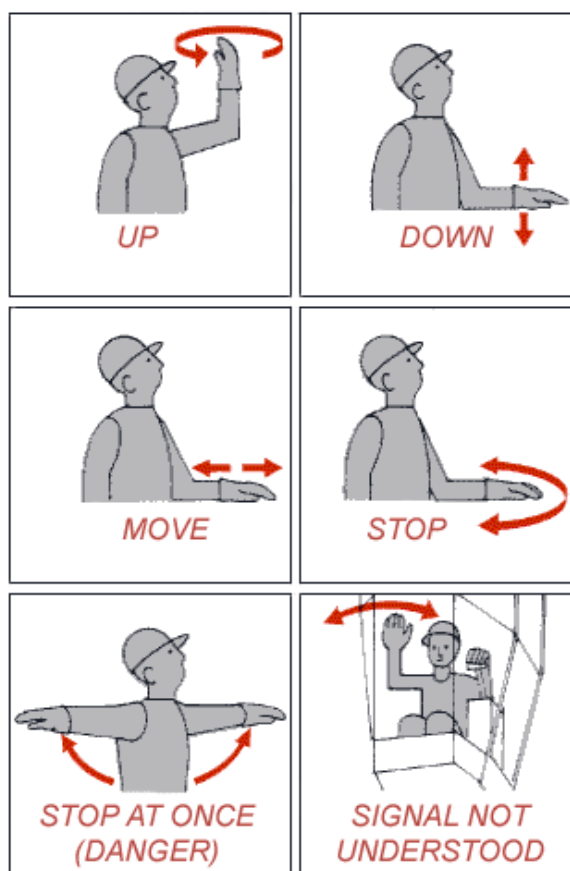

## Discussion

- Are there any rules about signalling when handling loads? What kind of rules do you think there should be?
- Can you describe the safety devices used on lifting equipment or cranes?
- Can you think of any new safety devices which could be fitted?
- Is the lifting equipment or cranes inspected and subjected to load tests? How often is this done?
- Is the frequency of inspection the same for all the equipment?

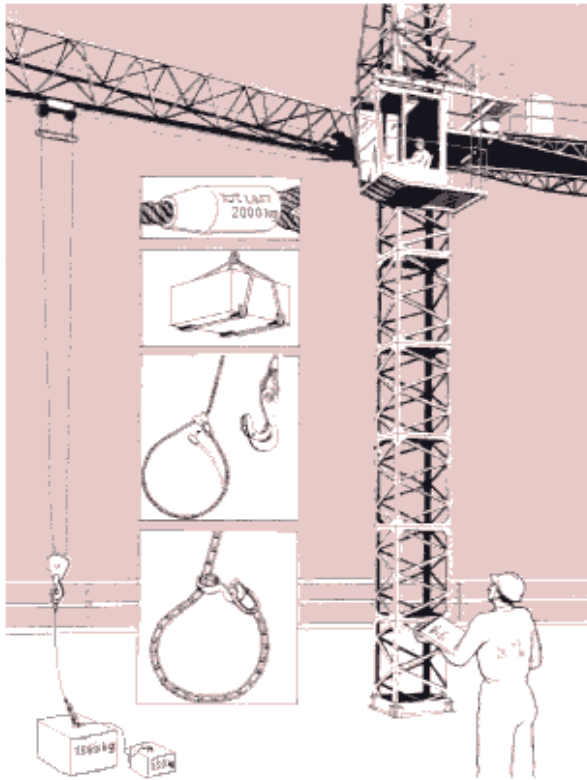

### Points to remember!

- Operators of motorised trucks and their assistants should wear suitable shoes to prevent foot injuries.

## Vehicles

### MOTORISED VEHICLES

Motorised vehicles should meet the following safety requirements:

- efficient foot and hand brakes
- the cab/operator's seat should be comfortable and should provide the driver with a good field of vision
- the controls should be within easy reach and easy to operate
- easy access to the cab/operator's seat
- a stopper or a close-off valve under the tip-up load platform
- well-anchored load
- exhaust system discharging away from the operator's position
- first aid kit and any necessary personal protective equipment in the operator's cab, depending on what is being transported
- fire extinguisher.

In addition, the operator must be suitably trained and wear appropriate shoes. Trucks are often involved in accidents leading to foot injuries. Most injuries occur during loading and unloading. The person helping the operator often runs the greatest risk. Both operators and helpers should wear suitable shoes.

The safety measures illustrated above should be used to reduce the number of industrial accidents connected with truck driving.

Work involving cranes and overhead travelling cranes must always be performed under supervision of a qualified and experienced person. The workers must be suitably trained. In many cases special training may be required, including the correct signalling procedure for giving instructions to the driver.

In this way misunderstandings and unnecessary risks of accidents can be avoided.



#### Safety rules for vehicles

- Training of driver
- Regular service and maintenance
- Regular testing and inspection
- No overloading
- Speed adapted to road conditions and load



## Safety requirements for machinery

When machinery or equipment is purchased, it should meet safety requirements. The first requirement is that the machine should be constructed in such a way that it is not necessary to add extra protection. Other safety requirements should include:

- all protection/guards, maintenance instructions and safety instructions should be included
- the machine should be sufficiently safe so that the operator will not be injured even if his/her attention should wander or he/she should make a sudden, reflexive movement
- guards or covers that can be opened while the machine is in operation must have switches or devices which cut off the electrical supply.

When the machine is installed, care must be taken to ensure that all the guards are properly fixed and used.

Certain machines will require special safety devices. Examples are press machines, cutters, shapers, etc. which require hand operations in the dangerous area. It is important that:

- the safety device does not constitute an obstacle to work
- the safety device will not hamper the maintenance services of the machine
- safety devices are built at all places where contact with moving parts could cause personal injury
- the safety devices should be strong enough to tolerate the largest loads they can be subjected to.

## Risks connected with machine work

### *MACHINES WITH INGOING NIP POINTS*

A particular hazard area is the ingoing nip points or "bites" where one surface rotates close to another. Examples of such machines include rollers in a rolling mill, mangles and other similar machines, cog-wheels, chains and sprockets, bolts or bands and band cylinders, conveyor belts and so on.

The best method of preventing accidents when working with such machines is to guard the nip points of the machine. If the guard cannot be complete, a supplemental protective guard must be put around the actual nip zone to prevent any direct contact with inrunning rolls or similar hazards.

### **Points to remember!**

- All nip points need protection. Never think just a warning sign is sufficient!

## Drilling machines

Risks connected with drilling machines include contact with the drilling spindle and the drilling surface. One common cause of accidents is getting the shirt sleeve caught in the spinning bore. This risk can be reduced by wearing arm covers, special arm guards or short sleeve shirts. People with long hair should use hairnets. This precaution applies to work with all machines with revolving parts.

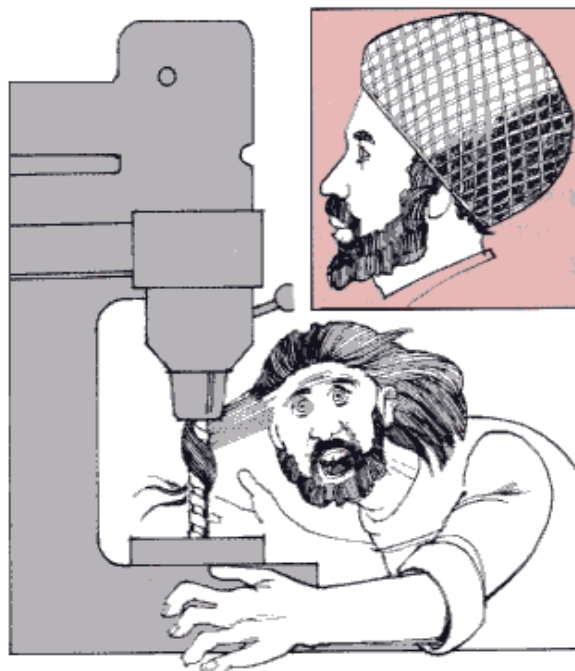

*Hair, loose fitting clothes etc. can easily catch in rotating machines and cause serious injuries. For example, drilling machines can be fitted with adjustable shields that prevent clothes etc. from fastening.*

## Machines for cutting and slicing

In many workplaces, there are cutting and slicing machines or tools. This category of machines includes grinding wheels blades for slicing or cutting, guillotines, band-driven saws circular saws milling blocks and planing machines.

Grinding machines are very common in metal work. The most common types of accidents connected with grinding are eye-injuries usually caused by flying dust particles or splinters flying from the grinding wheel. Accidents can also happen when the grinding wheel breaks while in use.

As a rule every stationary and manual grinding machine should have local ventilation. If there is no ventilation system, the worker should use a breathing apparatus.



### Points to remember!

- The safety requirements for grinding machines and grinding wheels are very high. A grinding machine should have a guard against the wheel breaking up during work, a splinter guard and a suitable adjustable balance plate. Always use some sort of eye guard, i.e. a partition of safety glass and safety goggles while working on a grinding machine.

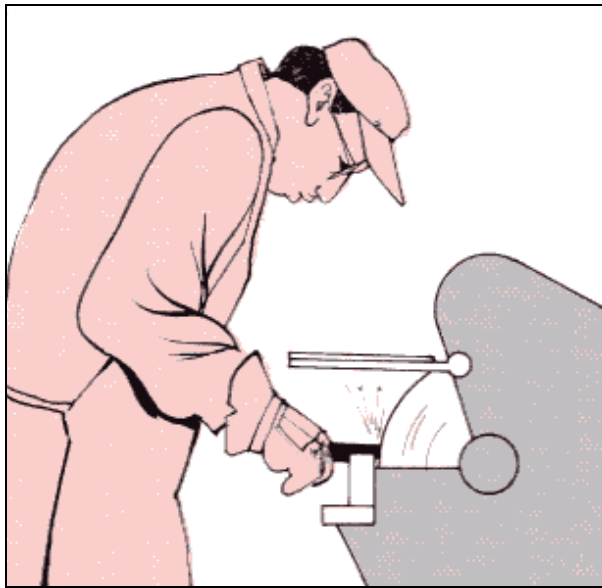

*If you lose your sight it can never be replaced. Always use protective glasses when cutting and grinding. Emery grinding machines must be equipped with spark shields. Protective glasses must also be available close to the machine.*

*Emery grinding and cutting disks can explode. They must be regularly checked. Replace cracked or worn disks. In addition, make sure that the disk is made to suit the speed of the machine's revolutions. The protective shield must never be removed.*

### Avoid eye-injuries

The best way of avoiding eye-injuries is to use eye protection. For a grinding machine the safety guard should consist of an easily adjustable partition of non splinter glass mounted on the machine guard itself and a pair of approved safety goggles.

A permanently fixed (stationary) grinding machine, i.e. a grinding bench should have a firm balancing plate attached to it. It should be easily adjustable and fixed in a position not more than 2 mm from the grinding wheel, slightly under the horizontal central line position of the wheel. The gap between the balancing plate and the wheel should be checked at regular intervals. If the gap is too large the object being ground can get stuck

between the grinding disc and the balancing plate. There is then a major risk that the wheel can be smashed. This can be fatal to the operator. To avoid this danger the wheel should be carefully suspended between two equally large flanges. The diameter of the flanges should not be less than 1/3 of the diameter of the grinding wheel. The best thing is to have the flanges with a diameter equal to one half of the diameter of the grinding wheel.

In order to reduce the risk of injury by the smashing of a grinding wheel, there should be a splinter guard of steel or cast metal. A splinter guard also helps to prevent the unintentional touching of the wheel.

### Discussion

- Explain what is meant by 'a nip point' and give some examples.
- What can be done to reduce the risks to the operators of such machines? Is this a design problem or a training problem or both?
- Describe the particular dangers associated with cutting and slicing machines.
- Describe, preferably with examples from your own experience, the kind of injuries which are likely to occur to people using such machines.
- What could be done to reduce the risk of accidents with these machines? Give some examples.

### Machine servicing

Careful servicing of machines is most important from the point of view of job safety. Never check or carry out repairs on a machine whilst it is operating! Even if the machine has stopped there is always a risk that it can suddenly start up again or be switched on by someone unaware of the fact that the machine is being repaired or serviced. Accidents of this kind are unfortunately all too common.

In order to avoid accidents of this kind, put warning signs over the starting motor and switch. A sign reading "Danger, work in progress – do not touch the switch" can quite easily fall off or accidentally be removed.

The best measure is to lock off the starting switch or starting motor and to remove the fuses.

### Discussion

- What are the arrangements for servicing and repairing machines?
- What are the particular risks associated with such work?
- What measures could be taken to reduce these risks?

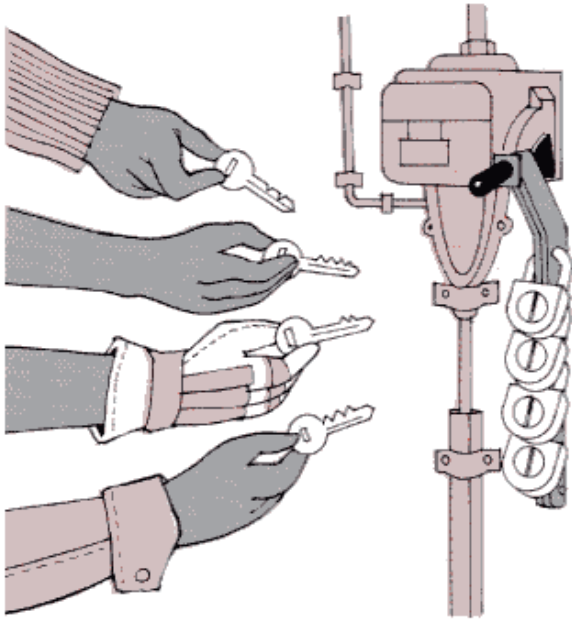

*... having the responsible repair man or supervisor lock the power switch in the off position. Where several maintenance workers are repairing large machines, a responsible coordinator must be appointed.*

## Safety design preventing accidental starting

Many injuries occur during inspection, repairs or maintenance on machinery because the machines are accidentally started. This type of work should not begin before the machine has stopped and a safety tag and lock had been put in place to prevent accidental starting.

Handles, buttons and pedals on the machine which are used to perform dangerous operations should be so designed and positioned that they cannot be accidentally activated.

Stop buttons on the other hand should be easily accessible and coloured red.

## Discussion

- Workers sometimes remove or neutralise safety devices on machines. What steps could be taken to reduce this possibility? Is this a design problem, a training problem, or both?
- What measures could be taken to make workmates and supervisors more safety conscious?
- What could be done to make sure workers remain safety conscious?

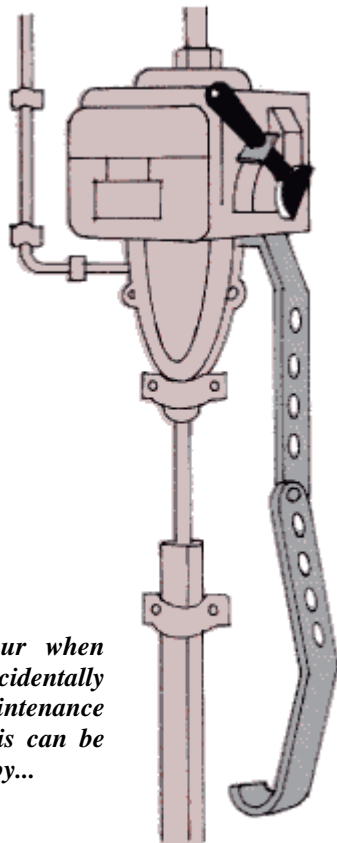

*Many accidents occur when machines are accidentally started during maintenance and repair work. This can be effectively prevented by...*

## Safety devices on machinery

For some machines, the provision of guards does not effectively prevent contact with dangerous parts. These include different types of presses and cutters, and machines with rubber rollers. Some of the following safety devices are used to prevent injuries when using these types of machines.

*Two-hand operation.* Both hands must be used at the same time to start the machine and keep it running.

- *Light beams* (photoelectric cell devices): A series of light beams in front of the danger zone (if a hand breaks the beams, the machine automatically stops operating).
- *Interlocking guard:* A guard which must be in the correct position to protect the operator before the machine can start.
- *Automatic cut-out:* The machine stops when someone or something enters the danger-zone.
- *Dead man's hand:* A handle which must be held in order to perform hazardous operations with the machine. When the handle is released the machine shuts off.

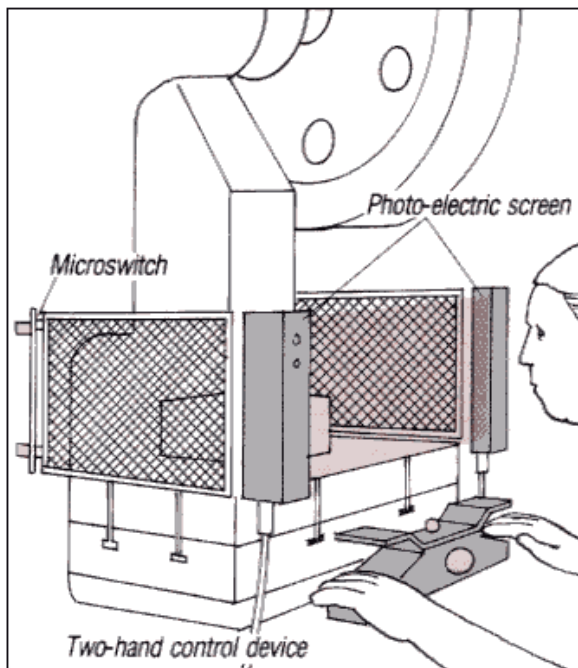

## Tools and equipment

### DIFFERENT TYPES OF TOOLS

Every year there are many industrial accidents resulting from the use of tools and equipment. These include manual and power-driven tools.

Many industrial injuries result from the use of equipment not suited to the particular purpose. Some examples: adjustable spanners being used instead of ring or open-ended spanners to tighten nuts; tin snips or

pliers with the handles bent toward each other at the ends; pipe wrenches with worn jaws; hammers with cracks in the handles, etc.

### Points to remember!

- You can prevent accidents by using the right tools for the job. They should be of good quality and well maintained. Replace tools before they wear out.

*Impact tools* (hammers, chisels, sledge-hammers, etc.) should be made of iron of the correct hardness. Burrs, which can fly off and cause injury, should be removed.

*Sharp-edged tools* (knives, axes, saws, etc.) should be kept sharp. The risk of injury is greater from blunt tools than from sharp ones. Tools which are carried around must be carried in such a way that they cannot cause injury.

*Power-driven hand tools* involve greater risks than hand-operated or stationary tools. Guards protecting saw blades and grinders must never be removed or swiveled out of the way.

## Regular inspection

All tools and work equipment must be inspected regularly. The supervisor should be responsible for this continuous inspection. Inspections should be carried out according to the instructions from the supplier of the equipment. These can take the form of a check list.

## Discussion

- There are many kinds of tools. Into what categories would you divide the tools?
- What are the risks associated with hand tools? What could be done to minimise these risks?
- Are tools inspected regularly? By whom? Do you think the instructions about regular inspections need improvement?

## Electricity and its risks

### ACCIDENTS INVOLVING ELECTRICITY

Electricity can cause accidents and fires. Accidents can occur when people touch part of a unit carrying live current. Even contact with part of a unit which does not normally carry live current can lead to serious accidents if the insulation becomes faulty. Where electric arcs are formed, there is a high risk of burning and damage to eyesight. We usually distinguish between:

- accidents due to direct contact with electricity



- accidents caused by the formation of an electric arc.

Electric current can also cause burns. If the insulation is faulty and there is a short-circuit, intense heat can develop, leading to the possibility of a serious fire.

Accidents involving electricity are often caused by failing to ensure that the safety system is working or by failing to follow the established safety rules.

All electric installations should be serviced only by qualified electricians.

### Points to remember!

- If an accident is caused by contact with electricity, switch off the current immediately! Failure to do so can result in death!  
Electricity can kill and should be dealt with by electricians; do not attempt to deal with power cable problems!

The risk of accidents is much greater when using portable motors or instruments. The insulating material used on such appliances is often subjected to heavy wear. Wires and cables are easily damaged, which can lead to short circuiting.

Should short circuiting occur in or near a container with a highly explosive mixture of gas and air, the results could be very dangerous. Using spirits to clean an electric motor, and then starting it up immediately after cleaning can also cause an explosion or fire.

A common cause of fatal accidents is the attachment of electric cables to gas tubes.

Wires and cables should not be hung over structural elements such as nails or other metal hooks, as these can wear through the insulating cover around the wires and cables.

Dragging and coiling cables and wires can also damage the insulating covering.

## Hand lamps

Hand lamps are among the most dangerous portable appliances in any workplace. Wherever possible, their use should be limited and they should be replaced by permanent lamps.

Where they must be used, it is important that the lamps used are of an approved design and that they are of the best quality. An electric hand lamp should have a framework and a hand grip made of insulating material, and have a protective basket around the bulb.

Hand lamps easily become worn and should be checked regularly to ensure that they are safe.

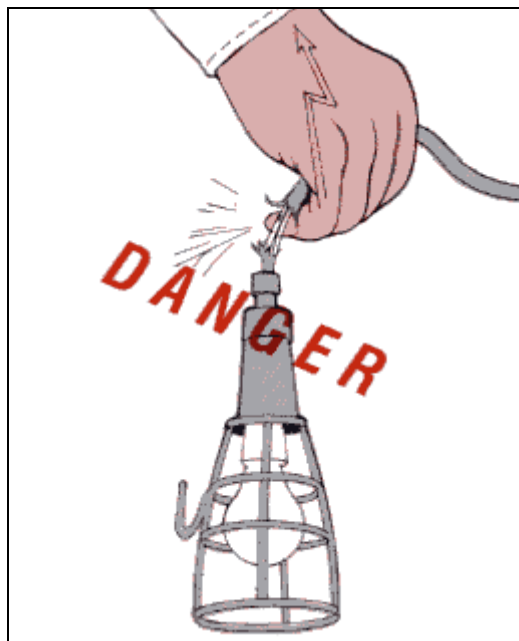

## Discussion

- Are hand lamps properly insulated? What sort of checks are carried out on the lamps?

## Power-driven machines

The only way to avoid accidents due to electricity when working with power-driven machines is to ensure that the machines are properly constructed and maintained in good working order. Those parts which carry current should be properly insulated. Elements such as control handles and driving wheels should be made of insulating material.

Elements such as motor frames and protective hoods should be earthed. Those who work on fixed electrical machines should stand on insulating material.

Wires and cables to machines should be fixed to the wall. Loose cables should be avoided; however, when necessary should only be used for appliances like hand lamps. Never use contacts which have not been properly approved and avoid sticking bare wires into contacts or similar dangerous make-shift connections!

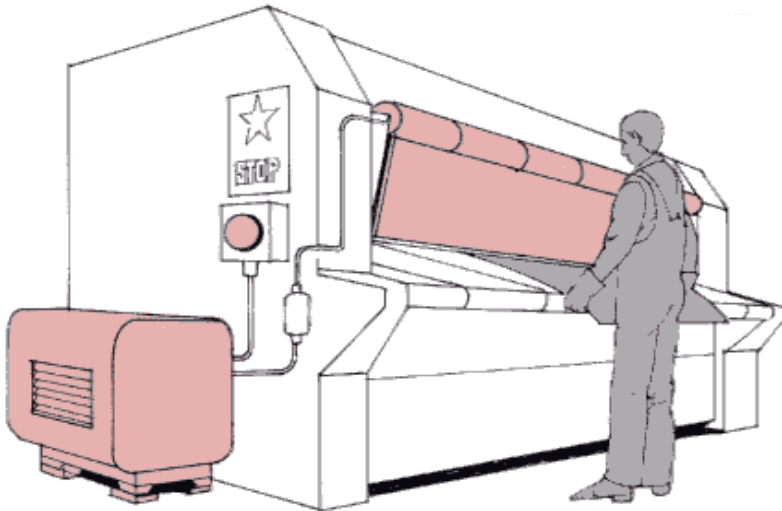

*An emergency stop device must be located within the operator's reach. It may also need to be reached by other people. This is the case with emergency stop buttons fitted to excavators, conveyor belts or automated production lines. Emergency stop devices normally immobilize all functions on a machine immediately. However, they must not cause dangerous movements such as putting electronic brakes out of action. Electrical machine installations should also be equipped with relays that trip when the current is too low or when there is a power cut. The relay must be reset before the machine can be restarted when the current has reached its normal level.*

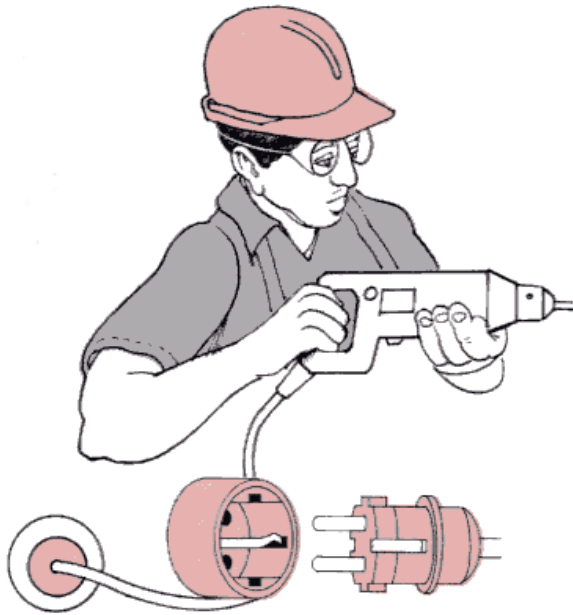

*Electrical equipment and machines must be earthed. Small portable electric machines, for example drills, can be double insulated instead. These machines have this mark: *

*In some environments, for example wet areas, low tension current (220V) is unsuitable. It is safer to use extra low voltage (<75V). Power is usually reduced to 24V, which requires special machines.*

## Power-driven hand tools

Power-driven hand tools frequently replace conventional hand tools. Since they involve greater accident risks, greater demands are made on the worker using them.

Power-driven tools should be fitted with a safety earth.

### Points to remember!

- Workers with improper training in the use of power-driven tools should not be allowed to use them.
- Always avoid working with live cables.
- Use a voltage tester to check that the cables are not live.
- Insulate yourself from live cables by using insulated tools and rubber gloves and footwear.
- Cover any live cables in the area with insulating material, for example special plastic covers.

## Discussion

- What are the proper procedures when a worker has received an electrical shock?
- What procedures are important in the maintenance of electrical switches?
- Are wires and cables properly treated? If not, what improvements are needed?
- Describe safety measures in dealing with power-driven tools.

## Welding

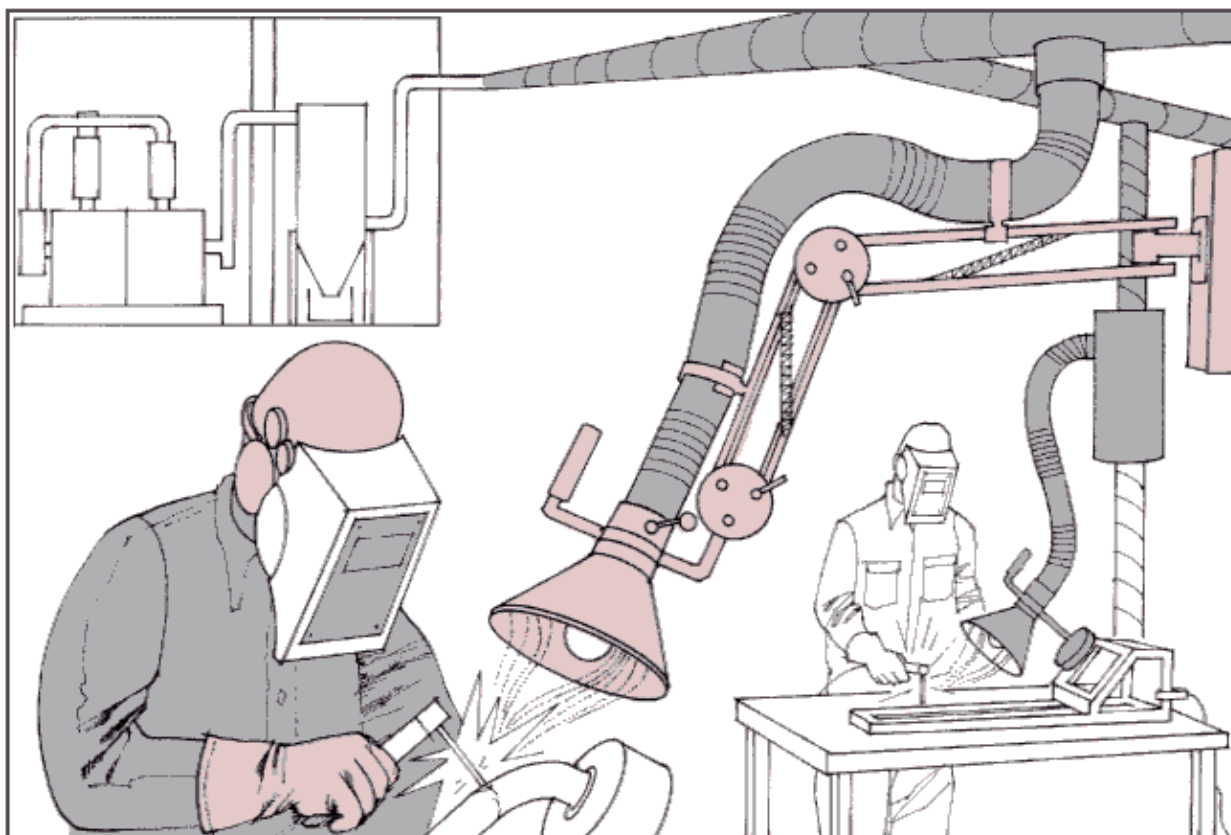

*Welding fumes are the most serious problem in all types of electric welding. The fumes contain a number of hazardous substances. Use local suction exhaust when working indoors, particularly in enclosed areas. The exhaust system must be placed as close to the point of the weld as possible. Screen off the work area to protect other people from welding glare. Earth the workpiece well, and if possible, place it at a comfortable working height, for example in a jig on a welding table. All paint, plastic and other pollutants must be cleaned off the workpiece. This is particularly important when gas welding.*

### **RISKS TO THE WELDER AND CO-WORKERS**

Welding jobs are carried out in many workplaces. The risks involve not only the welder doing the job but also those who are working nearby. The risks include eye damage, skin injuries, burns and inhalation of toxic gases.

On all welding jobs the welder should wear suitable protective goggles or a face mask to protect his eyes against the welding arc (a welder's helmet, for example). This applies even to the job of scraping off slag. The work area should be partitioned off so that people nearby are not exposed to the arc. The welder should also wear protective gloves.

Apart from the intensive glare, which is typical for all types of welding, we must note that in electric-arc welding the light-arc radiates invisible ultraviolet and

infra-red rays. These are dangerous and can damage the eyes and the skin. In such cases the eyes should be protected with a special type of filter glass.

The face and hands should also be carefully protected. The best way of doing this is to use a helmet and gloves. In electric-arc welding, there are also the added risks injury by electricity.

Some types of welding require effective air extraction from the work area. This is important when the welding is carried out on metals covered with an alloy of lead, cadmium, mercury, fluorine or zinc. Welding on such alloys leads to a build up of dangerous fumes and gases.

Gas welding in a confined space, especially when heating or straightening, can cause an accumulation of nitric gases, containing dangerous nitric oxides.

In cases where effective local ventilation cannot be arranged, the welder should be provided with

respiratory protection and a supply of fresh air. Always think about the safety of people working nearby and how they too can be exposed to dangerous fumes or gases.

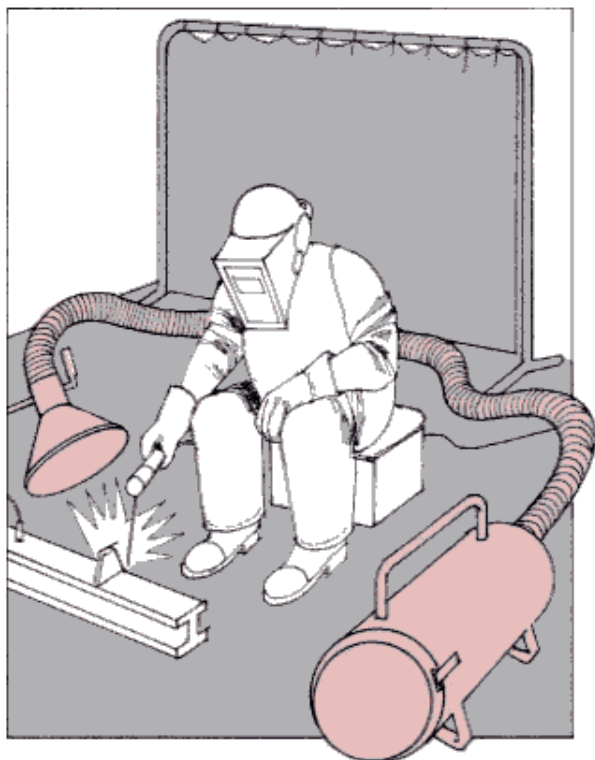

*If you are welding in different places you can use a smoke exhaust (smoke eater). It prevents the airborne dust particles in the welding air to be spread out into the work place.*

## Welding and the risk of fire

Welding in or near a room where flammable material is stored should never be allowed. Even more importantly, welding should not take place in a tank, container or similar apparatus which is used for storing flammable liquids, until the risks for fire or explosion have been removed. The tank (or container) must be thoroughly cleaned, preferably using pressurised steam, before any welding is carried out.

A further safety measure is to pump air into the tank or to fill it with water up to the level at which the welding job is to be carried out. "Welding bugs" are the biggest single cause of fires in connection with welding. A shower of sparks can cause a fire several meters away from the work area. This is often the case when the welding job is carried out at elevated levels. Experience has shown that burning particles can fly 20 meters through the air and cause a fire.

Acetylene and oxygen are normally used in gas welding. The oxygen and acetylene hoses should be

easily distinguished and gas cylinders should be stored in a safe place. In the event of a fire it should be easy to remove the cylinders to a safe place. The outside of the exit door should have a warning sign fixed to it reading: "Gas cylinders. Remove to a safe place in the event of fire." The gas hoses should be carefully protected against heat, sharp objects and dirt, especially oil and grease. These substances can – even in small amounts – cause an explosive ignition in the event of a leak in the oxygen hose.

## Discussion

- Is any welding carried out?
- Does every welder wear suitable protective equipment?
- Have you had any accidents in connection with such work? If so describe what happened.
- What safety measures have been adopted to prevent the occurrence of accidents connected with welding? What further measures would you like to see adopted?

## Boilers and pressure vessels

Boilers and pressure vessels need particular precautions. Especially stringent regulations apply to them. They entail risks of explosions or accidents due to component failures. The high internal pressure and frequent pressure changes give rise to these risks.

It is essential to make sure that boilers and pressure vessels are installed and operated according to regulations and maintained by qualified persons. They must be inspected at regular intervals by authorised, competent persons belonging to a state authority or to a recognised technical association.

## Good housekeeping

### **KEEPING OF ORDER – EVERYONE'S TASK**

Good housekeeping is an essential component of good working conditions. It contributes very greatly to the prevention of occupational injuries and diseases.

Housekeeping is a maintenance task and, therefore, everyone's task. Good housekeeping cannot be achieved without the goodwill and participation of everyone in the workplace. Good housekeeping is essential to good safety practice.

Housekeeping includes keeping buildings, plants, machinery and equipment organised and properly maintained; the upkeep of all sanitary and welfare

facilities; and the regular painting and cleaning of walls, ceilings and fixtures. Good housekeeping also includes day-to-day cleanliness, tidiness and good order in all parts of the workplace. Day-to-day housekeeping will considerably cut down the amount of maintenance work required.

Poor housekeeping produces:

- accidents – such as falls on slippery or greasy floors, stumbling on passageways, cuts from protruding parts, failure of lifts, etc.
- fires – from wastes or disorderly storage (aside from being trapped by fire)
- poor lighting – due to missing lamps, dirty fixtures or darkened walls
- health risks – from piled dust, unprotected contact with chemicals exposure to exhaust fumes, etc.

## Methods of order and cleanliness

Good housekeeping cannot be left to spontaneous, unplanned activities. It needs planning. Therefore, it will only begin when management takes responsibility for it. The layout of sections and machines must be in such a way that it is easy for order and cleanliness to be achieved and maintained. Day-to-day cleaning cannot be left to the last few minutes of the working day. Therefore, planning is essential.

The following are important points in observing good housekeeping:

- *Layout* to facilitate order and cleanliness.
- *Marking* of aisles, passageways, transport areas and exits. They must be cleared from obstacles.
- *Special areas* set aside for storage of raw materials, finished products, tools and accessories.
- *Racks* for hand tools or implements above work tables.
- *Underbench* slots or other spaces for storage of small personal belongings.
- *Receptacles* for waste and debris in convenient locations.
- *Floor-covering* materials suitable for the work and for cleaning.
- *Screening* and simple devices to prevent deposits of oil, liquid wastes or water on the surrounding floors.
- *Drainage* channels for waste water.
- *Special groups* of persons to carry out day-to-day cleaning and weekly or monthly cleaning.
- *Arrangements* to remove finished goods and wastes.

- *Clear assignment* of duties for maintenance and repair of work premises, in particular stairs, walk ways, walls, lights and sanitary facilities.

Needless to say, persons engaged in housekeeping must be protected from hazards. Cleaning should never be carried out when there is any risk of entanglement in machines. Personal protective clothing or overalls and hand and foot protection are often necessary to prevent injuries and diseases such as cuts from scrap metal or dermatitis from detergents.

Every worker should be responsible for cleaning his or her own workplace. The supervisor should take the responsibility to organise good housekeeping. Appropriate equipment for daily cleaning, such as brushes, brooms, vacuum cleaners, etc. should be provided.

### Points to remember!

- Asking workers to do last minute cleaning after the day's work never ensures good housekeeping. Good housekeeping needs good planning. The experience of planning and implementing good housekeeping will be useful for organising other safety activities. So start good housekeeping!

## Discussion

- Do you know of any accidents that occurred because of bad housekeeping?
- Is it easy or difficult to ask workers to maintain clean workplaces at all times? Give reasons why.
- Is the management aware of the merits of good housekeeping? If not, what could be done to make them aware?
- What are the first actions to take for improving the housekeeping at your workplace?



# USEFUL HINTS

## Work premises and housekeeping

- Sections and processes are located in good relation to each other.
- Layout of machines and equipment is suited to the work being done.
- There is suitable spacing between machines.
- Tidiness and good order is kept according to plans.
- Emergency exits are well marked, unlocked and kept cleared of obstacles.
- Suitable access routes to all the machines are secured.
- All transport routes and passageways are clearly marked and passable and, if necessary, have barriers.
- Clear warning signs and notices are put up for vehicle lanes and dangerous places.
- Enough space is supplied for storage of materials and products.
- Racks for tools, intermediate products, etc. are provided near the worksite.
- Adequate waste receptacles are conveniently placed.
- The floor is even and low steps that may not be visible are avoided.
- Floor surfaces are easy to clean and suitable for the work.
- Deposit of oil spills and water on the floors is prevented by screens or other devices.
- Suitable drainage channels are provided.
- Responsibilities for day-to-day cleanliness are clearly assigned.

## Lifting and transport equipment

- Maximum load is noticed and observed.
- Lifting equipment and vehicles are regularly checked.
- Control and other safety equipment are in good working order.
- No work is done under loads travelling overhead.
- An emergency stop device or brakes are in good order.

- Loads are firmly hooked or anchored to the lifting equipment or vehicle.
- Operators of lifting equipment and vehicles are adequately trained and retrained as necessary.

## Machine and tool work

- All dangerous parts in power transmission are guarded.
- All machine guards are securely fastened or can be interlocked.
- Grinding machines have a guard against wheel smashing.
- Eye-protectors and goggles are used to prevent eye injuries by flying splinters.
- All ingoing nip risks are guarded.
- Machines for operations such as cutting, grinding, pressing, have stopping or braking devices.
- Dangerous points of operation are guarded against possible contact with parts of the body by guards or safety devices.
- Warning signs and locking to prevent inadvertent start-up while maintenance is done.
- Workers' hands do not come in contact with sharp edges.
- Machines and tools are regularly maintained.

## Electrical safety

- Power-driven machines and equipment are kept in good order.
- Parts conducting current have an extra layer of insulation.
- Exposed parts of power-driven machines and tools are earthed.
- Machine wires are fixed to the walls.
- Electric arcs or dragging wires are avoided especially around containers of explosive gases.
- Only the approved design of hand lamps with an insulated framework is used.

## **Welding**

- The work area is partitioned off.
- Gas cylinders are placed in a stand and stored at an adequate distance.
- Suitable protective goggles or a face shield protector are used.
- Protective gloves are used.
- Effective ventilation is provided during welding work.
- Cables are whole and free from defects.
- Welding near flammable materials is prohibited.

## **Inspecting machinery**

- Safety and maintenance instructions are provided.
- All the necessary guards are provided.
- The machine is properly insulated against electrical hazards.
- The machine is stable.
- Accidental operation of switches or levers is prevented.
- Emergency switches are easily identifiable.
- The machine is easy to install.
- The worker can always see what he is doing.
- Special lighting, if needed, is provided.
- The feeding of materials and removal of products is easy.
- Proper disposal of waste materials is ensured.

## **First aid and fire fighting equipment**

- Adequate first aid equipment is provided and checked regularly.
- Qualified first-aiders are present during all shifts.
- Adequate fire-fighting equipment is provided.
- Fire-fighting equipment is maintained in a usable condition.
- Locations of fire-fighting equipment are posted.
- Workers are trained in the use of fire extinguishing equipment.
- Emergency telephone numbers are posted.

# WORKPLACE CLIMATE LIGHTING AND NOISE

*“Heat, inadequate lighting and noise not only cause discomfort but affect safety, health and work efficiency. Although you can feel, see and hear these conditions, they are frequently neglected.”*

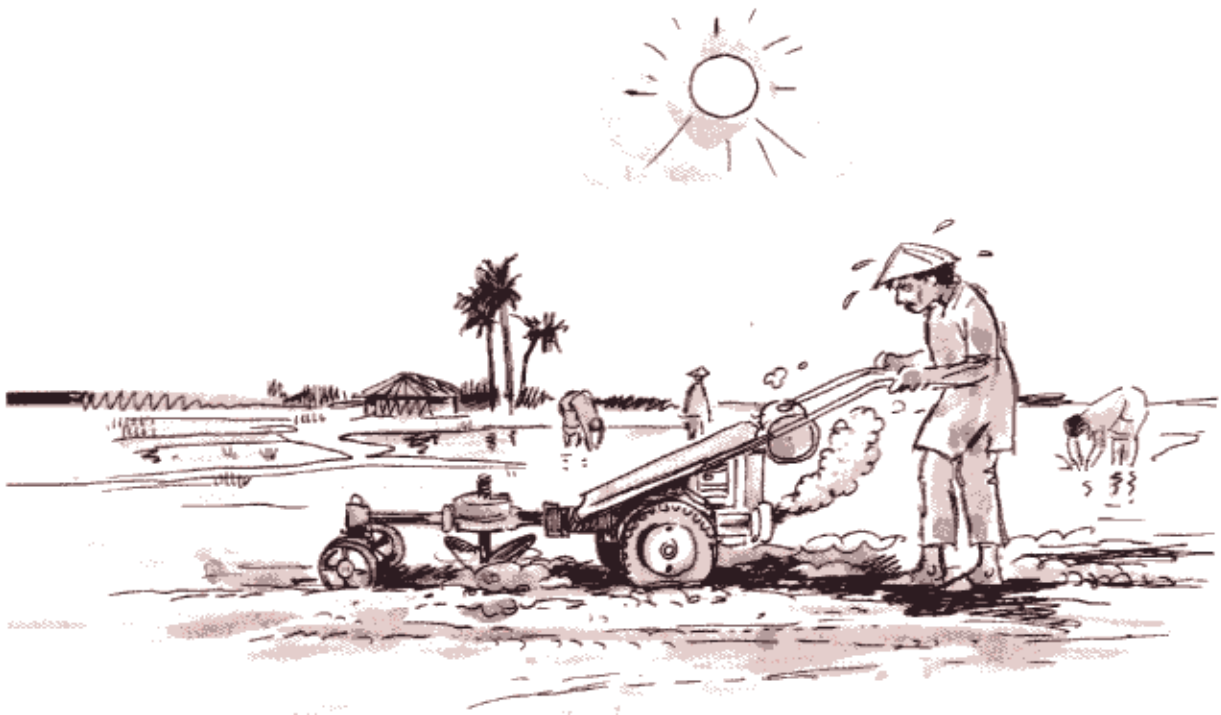

## Working conditions influences work performance

The work area temperature, the amount and quality of light and the levels of noise are common working conditions factors found in all workplaces. These conditions can affect safety and health in factory premises where mechanisation and automation have brought about changes. If inappropriate or excessive, these factors can strongly influence how a task is performed and affect productivity.

These are important safety and health factors. For example, hot, humid conditions add to fatigue and cause potential health risks, and noise makes hearing of warnings impossible, causes misunderstanding and can lead to permanent loss of hearing.

Techniques to regulate temperature, provide adequate lighting and reduce noise are constantly being developed. Effective guide-lines are made to protect workers from health risks. We must determine existing workplace conditions and try to improve them by finding practical solutions.

In this section, we will discuss:

- work area climate
- heat stress
- protection
- effects
- lighting
- effects of noise
- methods of noise control
- hearing protectors



## The workplace climate

The climate is the condition of the atmosphere surrounding us. It can mean the general conditions in a geographical area or, in a narrow sense the local atmospheric conditions in a specific workplace. The workplace climate (often called “microclimate”) is greatly influenced by the general climate.

In the hot season, we feel very uncomfortable and our efficiency of work drops. With higher living standards and technology, we are sometimes able to control the climate in the space we live or work in. In factories or in outdoor work, however, we are often exposed to intolerable heat and therefore need to take measures to reduce the harmful effects of heat.

We can also reduce the heat by installing air-conditioning. This however is costly and cannot be universally applied. It is also important to have an adequate exchange of fresh air.

## Body heat balance

Physical work produces heat in our bodies. In order to maintain normal body temperature, the body must get rid of excess heat. Body heat balance must be maintained.

Body heat balance is simply a balance between the body's heat gain and heat loss.

There are three main sources of heat:

- air temperature, wind and humidity
- radiation from the sun, machines and processes
- muscular work

Additionally there are three ways the body loses heat:

- convection (conveying heat from our skin to air); heat loss is greater when wind speed is high. Conversely, however, we absorb heat when the air temperature is higher than our skin temperature,

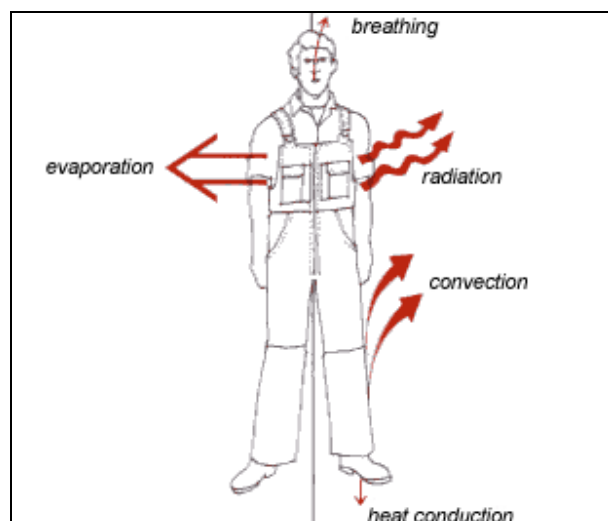

- radiation (when the skin radiates heat to cooler surfaces around). If, however, the skin is exposed to heated surfaces, we absorb heat. The latter happens when we are in the sunlight or near a furnace, heated tank, etc.,
- evaporation (when perspiration, namely water, evaporates from the skin, it takes away heat from us). Naturally, this heat loss by evaporation is facilitated by wind and is hampered by high humidity.

Therefore, in a hot climate there are several ways in which the body absorbs heat, but it can effectively lose heat only through perspiration.

In order to maintain body heat balance these factors must be within a limited range. This range varies from person to person, with season, clothing, job stress and culture. However, the *comfort zone* accepted by most people ranges from 20° to 25°C, with relative humidity of about 30 to 70 per cent, if the physical workload is light and there is no radiant heat.

As the physical workload increases, cooler air temperature is needed to maintain comfort. Because the working muscles generate heat during physically heavy work, comfort is only maintained below 20°C.

Increased wind speed is a positive comfort factor when air temperature is at or above the upper limit of the comfort zone. Air velocity of 0.1 to 0.3 metre per second is fairly typical of the comfort zone for light work.

When the local climate does not permit our body to get rid of excess heat or retain a normal body temperature, we experience real discomfort. Then our ability to work is impaired. In extreme cases we may end up completely exhausted or even incapacitated by ill-health.

### Points to remember!

- Our body has the ability to maintain a normal body temperature by losing heat. Outside the comfort zone, this ability can no longer ensure heat balance. The discomfort you feel in a hot zone is a valuable warning sign.

## Measuring heat stress

The degree of heat stress can be measured either by measuring the state of the hot zone or by measuring the body-state of someone in that zone.

## Measuring the working conditions

These are the four main variables which influence the degree of heat stress:

- air temperature
- relative humidity
- globe thermometer temperature (radiant temperature)
- wind speed.

To measure these variables, we use the following instruments:

- a thermometer* (sometimes called dry-bulb thermometer) is used to measure air temperature in the shade. Air temperature can vary from below zero to up to about 50°C;
- a wet-bulb thermometer* is used to measure the humidity with a dry-bulb thermometer. The lowest part, or bulb of the wet-bulb thermometer is kept wet by cotton gauze placed over the whole bulb, with the end of the gauze (but not the bulb) in a tiny can of water. When the air is dry, the water in the gauze will evaporate quickly and the temperature reading will fall. If the humidity is high, the water will evaporate slowly and the two temperature readings differ only a little. By taking the difference between the two readings and finding its value in the table you can find out the percentage relative humidity. The relative humidity can be between zero and 100 per cent;
- a globe thermometer* is used to measure radiant temperature, which can be quite different from air temperature. The thermometer's bulb is placed in the middle of a 15 cm diameter hollow black copper sphere. The black globe absorbs radiation and warms the air inside;
- an anemometer* is a wind speed gauge. An alternative method is to use a Kata thermometer which has only two marks on it. It is put in warm water until the mercury exceeds the top mark. It is then dried and exposed to the air. The time required for the mercury to fall from the top mark to the bottom mark is measured by a stopwatch. Using an attached table, you look up the wind speed from the time taken for the thermometer to cool.

In some cases, these four measures may be combined into a unified single indicator of heat stress.

It is important to see whether the air temperature does not considerably deviate from the comfort zone, and whether the radiant temperature is minimised at the place where the work is conducted, especially when the relative humidity is high. We should then note that

moderate wind speed usually helps us reduce discomfort.

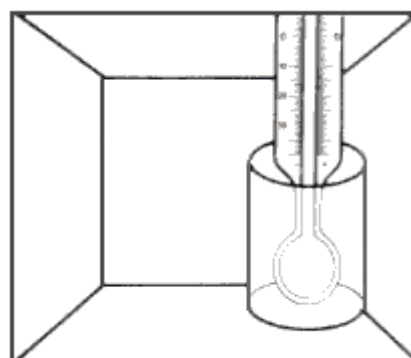

**AIR TEMPERATURE**  
*is measured using an ordinary thermometer. The bulb is protected from direct radiation by a polished cylinder which is open at both ends. Take the reading after ca 5 minutes.*

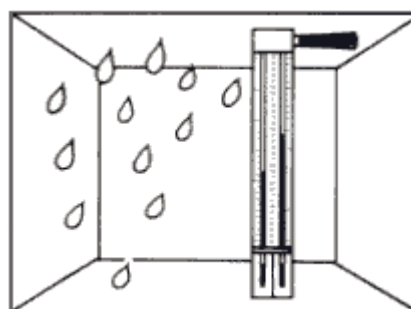

**AIR HUMIDITY**  
*can be measured using a wet and dry bulb hygrometer. Other instruments can be used e.g. a thermohygraph which registers humidity over a longer period.*

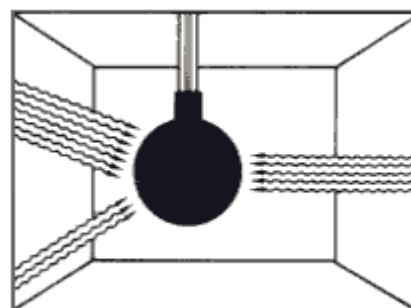

**RADIATION TEMPERATURE**  
*is measured using a globe thermometer. Read the temperature after 20-30 minutes.*

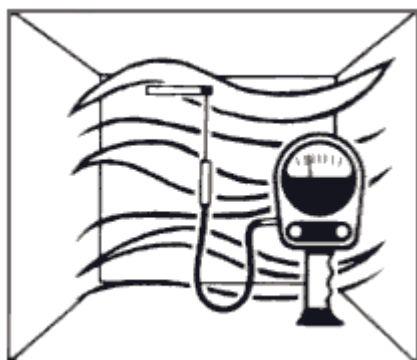

**AIR SPEED**  
can also be measured with an expansion instrument specially designed for low air speeds (0.2 m/s), that often occur in work premises.

## Measuring the person

When a worker is under heat stress, body temperature will rise. The body reacts by using its various mechanisms to keep the body temperature as constant as possible. The skin temperature will rise (the heart beat will increase, breathing will normally be deeper; and the worker will perspire. Thus the body temperature (core temperature measured in the mouth) will show the result of all these protective mechanisms. However the body temperature should not change by more than about 1°C.

For most levels of heat stress found in industry, the rate of perspiration indicates the strain produced on the body. The amount of perspiration in a working period can be measured by calculating the loss of body weight discounting the weight taken in by eating and drinking, weight lost when going to the lavatory, and any changes in weight of clothing. This can be up to a few kilogrammes after a day's work in hot environment.

Perspiration contains salt. If there is a lot of perspiration, the body loses a lot of salt. In extreme cases, cramp occurs in muscles due to a shortage of salt in the body.

The water and the salt lost by perspiration must be replaced. Unfortunately it is not enough just to drink when you feel thirsty. A fit young person in a very hot zone can lose more than one litre of perspiration in an hour. But normally he can tolerate losing up to about 4 litres in an 8-hour shift provided he replaces the water and the salt. The replacement should be by drinking either pure water or by drinking fruit juices. Adding salt to food and eating foods that contain natural salt and other minerals will also be helpful.

Anyone not taking in enough water to replace perspiration loss will not pass very much urine; that which does pass will be strong and darker in colour. This is unhealthy.

Perspiration is essential. The body will never perspire unnecessarily. It is dangerous to try to reduce perspiration by drinking less.

Two medical effects of heat are heat exhaustion and heat stroke:

- *heat exhaustion* is when you feel dizzy and faint and is due to a shortage of blood to the brain. Blood pressure falls. Lie down in a cool place so that the blood can flow to the head;
- *heat stroke* is when the workers skin is very hot and dry and is due to the perspiration mechanism not working properly. There is a rapid rise of body temperature to over 40°C, frequently with cessation of sweating. This is a medical emergency and medical assistance must be summoned immediately. While waiting it is vital to cool the body by sponging.

*Acclimatisation* occurs when a person lives and works in a hot climate. It means that the person has adjusted and adapted to the hot climate. For fully acclimatised people, body temperature and the heart rate react less to working in heat. They perspire easily and the perspiration is less salty. They can also have greater blood circulation near the skin.

There is, however, a limit to how much the body can adapt. Even for the fully acclimatised person heat stress should be reduced as much as possible.

### Points to remember!

- Perspiring is essential. The body will never perspire unnecessarily. As losing a lot of water and salt by sweating is not healthy, we should try to create working conditions where we need not perspire much. It is dangerous to try to reduce perspiration by drinking less.

## Discussion

- Is the local climate within the comfort zone?
- What indications would you find if a worker is supposed to be suffering from strong heat stress?
- What are the factors which increase heat stress?
- How does the body protect itself against heat stress?
- Is cool and drinking water provided at your workplace?

## Protection against heat

### HOW TO KEEP THE WORKPLACE COOLER

There are various ways to keep the workplace cooler. The basic ideas are to prevent outside heat from coming in and to increase ventilation, as in traditional houses in tropical climates. Remember to:

- *retain* the evening cool as much as possible by having fresh air in the evening and by considering the building features. In places away from the sea it is much cooler in the evening and morning than in the middle of the day;
- *open* the windows and doors very wide to increase the natural ventilation;
- *avoid* floors which retain heat, such as dirt, solid wood and carpets. Increase air circulation beneath the floor;
- *design* the roof to let the heat escape. The material of the roof and the way it is constructed are particularly important. Good ventilation near the roof makes a vast difference. To avoid direct radiation from the roof, change the material or ceiling underneath. A roof painted in light colours will reflect away the heat from the sun and the sky;
- *make* eaves or other overhangs longer so that walls are in the shade for longer periods. The walls, particularly those which are in sunlight, should be painted in lighter colours. Avoid metal or thin materials for walls which are easily heated by the sun;
- *use* light colours for inside walls. Light-coloured surfaces radiate less heat than do dark coloured surfaces. They may also give a psychological impression of coolness;
- *make* ceilings high. High ceilings are better than low ones;
- *install* ventilation devices. Artificially induced ventilation for extracting air or pushing air in, is helpful;
- *circulate* the air by using electric fans.

### Hot machines and processes

Hot machines or processes greatly add to the heat stress. The operator must be protected from the heat.

The normal steps are:

- *hot machines or processes* should be located outside or at least near the outside so that the heat can escape;
- *hot surfaces* should be insulated by the use of material such as foam or polyester over the metallic surface. This keeps the heat in, saves fuel costs, and

reduces the possibility of accidents through contact with the body;

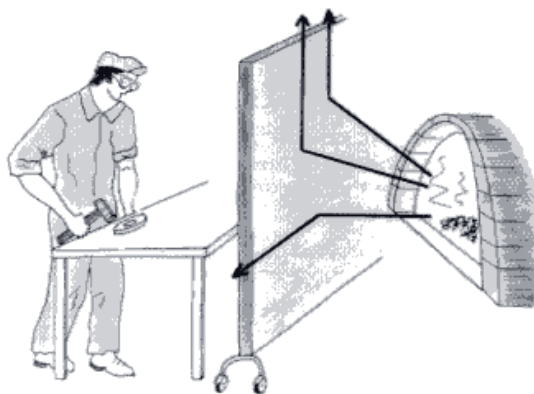

- *barriers* should be placed between the heat source and the workers. Some effective heat barriers in the workplace are aluminised reflective partitions, water curtains, and wooden or fabric-covered standing panels;
- *heat-protective aprons or clothing* should be used such as an aluminised jacket. However, this approach is not recommended for jobs with long exposure to moderate to heavy work, because the high insulation value of the clothing prevents evaporative heat loss;

It is seldom worth-while to try to reduce strong heatradiation with the help of a hot air extractor. The only really effective way is to partition off the heatradiating surfaces so that the heat waves are deflected away from the workers.

### Points to remember!

- There are reasons why some traditional houses in a shady wood are cooler. They make use of various ways to prevent unnecessary heat radiation and increase ventilation. We should be as wise as our ancestors. Make full use of vents, shades, screens and natural ventilation.

### Air-conditioning

Air-conditioning provides an indoor climate conducive to the health and comfort of people. An air-conditioning system usually simultaneously controls temperature, humidity and cleanliness of the air. Air-conditioning is costly, especially in factories, but it is sometimes a worth-while investment. It is known that air-conditioning increases productivity, helps reduce

accidents decreases absenteeism and improves human relations.

*An air-conditioning system should:*

- be of an appropriate type to meet the requirements of the air-conditioned space;*
- take into account the concentrations of gases, vapours, and dusts of within the space;*
- adjust the system functions to the comfort of the people in the space, not to the thermometer readings;*
- avoid overcooling and uncomfortable draughts;*
- maintain the conditioning equipment in good order, including its elements controlling humidity.*

## How to keep the body cool

Besides all these technical measures, it is helpful to learn how to keep the body cool. Heat energy comes from inside the body. There are means to restrict heat gain and facilitate heat loss from the body. Try to:

- avoid unnecessarily quick movements;*
- think out how to do physical work in a less heavy way and with less exposure to hot surroundings;*
- keep out of the direct sunlight;*
- stand or sit in a place where there is a breeze from open doors or windows or fans;*
- avoid closed positions where air circulation is restricted. If seated, use a seat in which air can be circulated;*
- keep away from sources of heat such as hot liquids, machines and fires. Consider whether any barrier can be placed;*
- never wear any tight clothes or those which prevent evaporation of perspiration;*
- take cool drinks regularly;*
- organise a cooler place for rest pauses.*

Improving conditions of work and welfare facilities is essential for work in a hot zone. The effects of heat, combined with physical workload, tend to accumulate. Arrangement of working time is particularly important. Remember to:

- avoid long hours of work when heat conditions are particularly severe;*
- ensure sufficient work breaks. Especially in physically moderate or heavy work done in a hot, humid climate or in radiant heat, 50 per cent or more rest time is essential to prevent body temperature rise. Shorter actual working time does not necessarily mean less production;*
- provide places to cool off away from work;*

- ensure a supply of cold drinking water near the workplace. Liquids should be taken in small quantities and often;*
- provide good washing facilities and access to cleaning of work clothes.*

### Points to remember!

- The heat generated inside the body by physical work adds to the heat coming in from the surrounding. Many people working heavy jobs in front of furnaces and similar equipment have a body temperature reaching 39°C (100F). To cope with the hot temperature, we need to reduce physical workload and secure rest breaks.

## Discussion

- What are the basic technical measures to protect workers from heat stress?
- What are your recommendations in reducing the physical workload? Do they include rest breaks and resting facilities?

## Protection against cold

Although cold is not usually a serious problem in the tropical climate, it can occur at high altitudes at night and in the morning in places well away from the sea. The sea and large lakes have a very strong influence in reducing the temperature difference between night and day. This is because water absorbs more heat during the day and releases it more slowly at night.

People working with cooled or frozen foods are also exposed to a cold surrounding. The large temperature difference between the cool room and the outside climate is uncomfortable and may be unhealthy.

Exposure to cold for short periods of time can produce serious effects, especially when exposed to temperatures below 10°C. The loss of body heat is uncomfortable and quickly affects work efficiency. Long exposures or extreme cold endanger survival due to a drop in body temperature.

Exposure to cold can be reduced by wearing thick clothing and gloves.

In a cold zone, body heat loss is accelerated by air movement. In fact the best protection against cold is to reduce air movement over the skin thus reducing heat loss through convection and evaporation. This can be done by both clothing and protection from the wind.

Work in a cold zone gives rise to multiple problems such as:

- The hands and feet feel the cold first, then the arms, the legs and finally the rest of the body.



- ❑ The worker will show a lack of co-ordination which reduces the speed and quality of work as well as safety. In addition to clumsiness, a loss of concentration from discomfort greatly affects safety.
- ❑ Bulky clothing can also be dangerous. It interferes with movements and it can easily get caught in the working parts of machines. The same applies to thick gloves.
- ❑ Handling metal or liquids causes the hands to become cold more quickly.
- ❑ Exposure to cold, especially at temperatures below 0°C, may result in frostbite of the fingers, toes, nose and earlobes. This is irritating, painful and dangerous.
- ❑ Damp cold is less pleasant than dry cold. This is mainly because dampness reduces the insulating properties of all clothing except wool.

**Points to remember!**

- Cold has a great influence on safety, even if the worker is exposed to cold for very short periods.

Heating is less expensive than air conditioning, and well designed clothing can provide protection against almost any climatic conditions. However, careful planning is necessary, and following precautions must be taken:

- ❑ Choice of clothing should take into account the protection from wet and wind and the escape moisture. The body perspires at all temperatures. Waterproof clothing tends to prevent evaporation. The clothing then gets wet from the inside. Adequate protection allows moisture to escape but does not allow rain and wind to penetrate.
- ❑ Bulky clothes should be avoided as they hamper movement.
- ❑ In heavy work, overheating under thick clothing is a problem. A number of layers of clothes (vest, shirt, pullover, wind jacket), which can be removed one by one, should be worn, or quilted clothes with zip fasteners.
- ❑ Hands and feet are particularly susceptible to cold.
- ❑ Older people need more protection against cold than do younger people.
- ❑ Machinery and tasks must be carefully designed to make them less hazardous and easier to perform (e.g. size and spacing of knobs, insulation of metal parts, elimination of sharp protrusions, etc.).
- ❑ Provision of comfortable, heated rest facilities is essential.

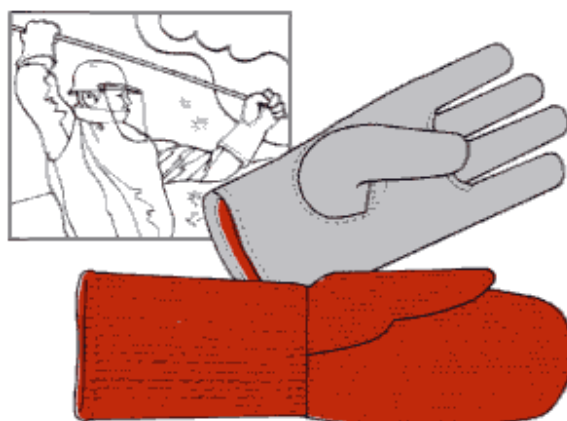

**HIGH TEMPERATURES.** Use e.g. thick, lined gloves of elk hide. Inner gloves of wool treated to be flame-resistant. The Fortamid mitten will withstand 400°C.

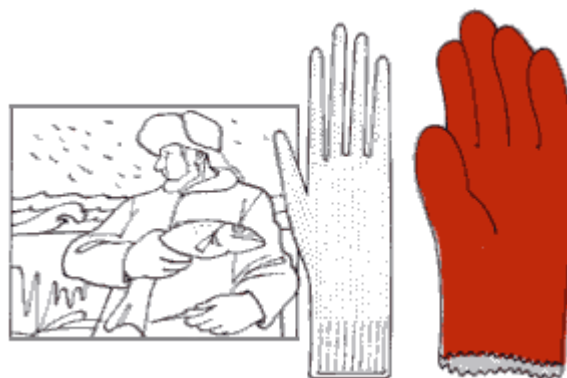

**HUMIDITY AND COLD.** E.g. short PVC gloves. Use a knitted inner glove of moisture-resistant material.

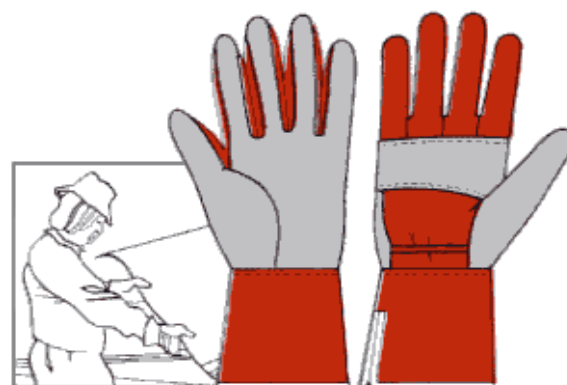

**LEATHER GLOVES** are all-round gloves for heavy duty use in dry work. Reinforced gloves last longer.

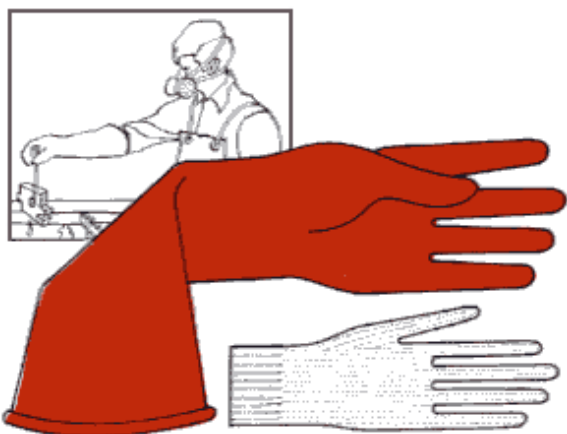

**WORKING WITH CORROSIVE SUBSTANCES.**  
 Use long rubber gloves of chloroprene rubber with knitted inner gloves of moisture absorbing fibre with a long cuff.

### Discussion

- Are there any work situations exposed to cold in your area? Do the workers know the risks associated with cold?
- What are the particular safety measures necessary in a cold environment?

## Lighting

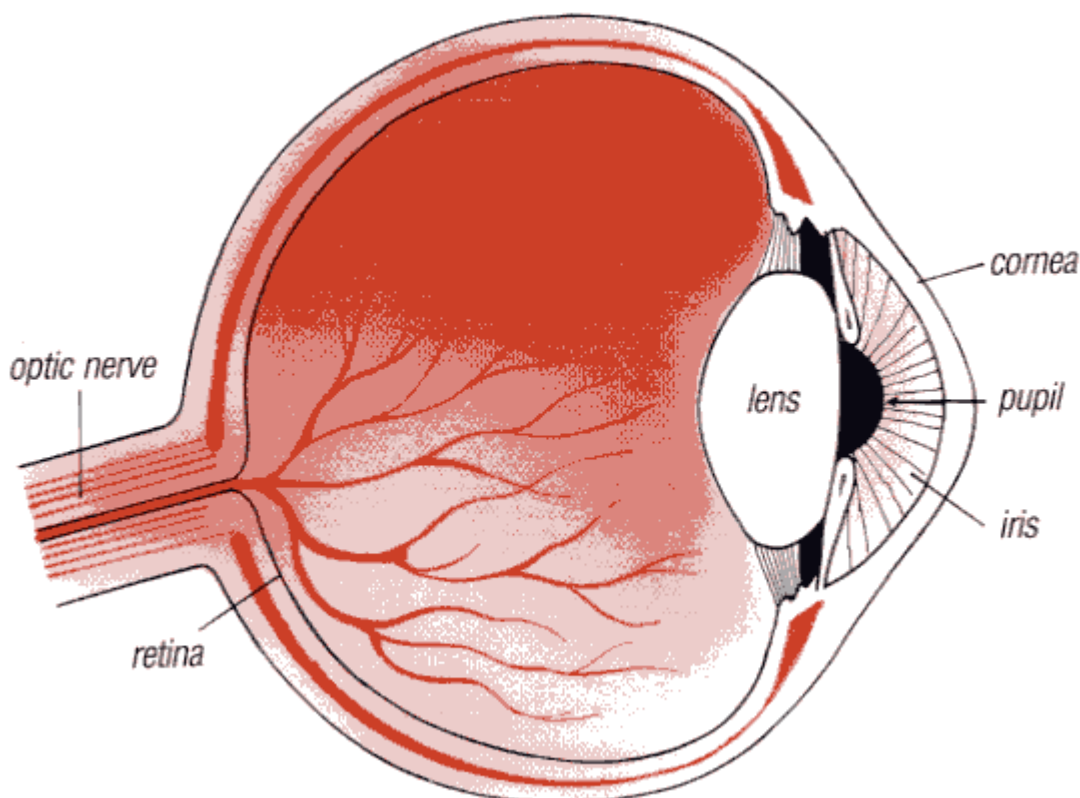

*The iris is the coloured part of the eye. The black hole in the middle is the pupil. The size of the pupil is determined by the amount of light hitting the eye.*

### THE EYE NEEDS ADEQUATE LIGHTING

We often forget how important lighting is both at home and at work. Our eyes can adjust to a wide range of brightness, but inadequate lighting makes it difficult to work and contributes to accidents. Poor lighting can also result in eye problems.

For most jobs we need to see the materials, products and other equipment clearly. If we cannot see well we may easily suffer from tiredness, over-exertion and headaches.

The eye can be compared to a camera. When rays of light fall on the eye they are broken up by a lens system consisting of the cornea, the lens and a watery liquid

between the two. The space inside the eye behind the lens is filled with a transparent liquid through which the rays pass to form an image on the retina, the curved screen at the rear of the eye. The retina is like a light-sensitive film in a camera.

Adequate lighting is important, for the following reasons:

- *Focus:* The eye cannot focus simultaneously on objects which are close and far away. When we rapidly change our focus on objects at different distances, the eye becomes tired. This can occur in inspection or assembly work. In such cases there should be plenty of light available, particularly at the area furthest away from the eye.
- *Changes in the eyesight:* Everybody's eyesight is different. Some people have weaker eyesight. Moreover, the ability of the eye to adjust rapidly to different distances declines as we grow older. Many people need glasses by the age of 40-50.  
It is particularly important that older people have adequate lighting.

## Eye testing

If you are unable to read this test with your eyes not closer than 40 cm your vision is less than 1.0. Contact an optician.

- You can test your vision by trying to read the above text.

- If you find it difficult to read in good lighting you should have your eyes examined and see whether or not you need glasses.

Lighting requirements at workplaces should make good use of natural light and at the same time avoid disturbances by sunlight or other light sources.

## Daylight

Artificial lighting is not as good as daylight, but daylight varies with the seasons and weather conditions. Consequently the amount of lighting required should be determined regardless of the amount of daylight.

Adequate lighting should reach your work area without being shadowed by you or part of a machine. This holds true with either daylight or artificial lighting.

It is important to get as much daylight as possible. Stored material should not be piled up where it blocks daylight. Windows should be kept clean, inside and outside. If the window faces a wall, that wall should be painted white so as to reflect more daylight into the work area.

In factories, windows and skylights can help increase lighting. However, adequate general lighting should be provided as sunlight may become inadequate at different times of the day.

Walls inside the factory should be painted light colours to make the most of daylight as well as artificial lighting.

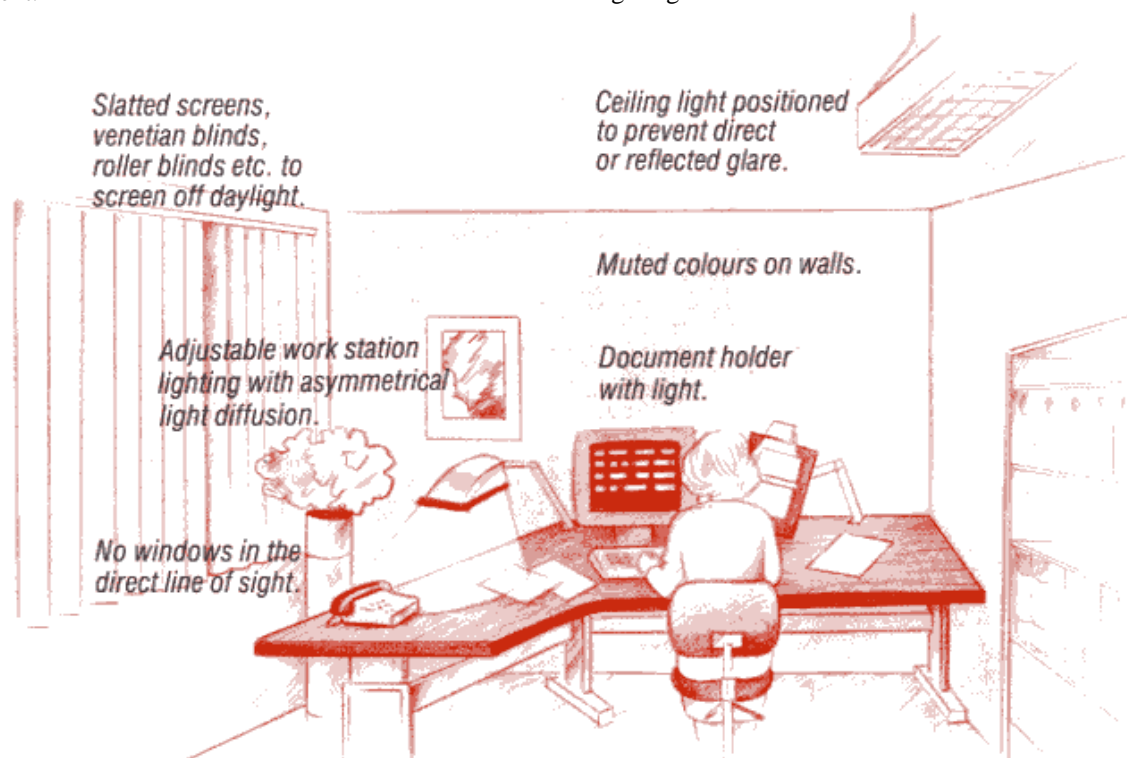

**Points to remember when planning, positioning and screening of VDUs in offices. Work at a dark monitor. In general, lighting must be far weaker than at other office workstations.**



## Contrast

The eye has to make an effort to distinguish between objects which have little contrast. It can be particularly difficult to distinguish such objects when lighting is dim. Moving from a very bright area, (from direct sunlight or acetylene lighting) to a shaded area can be dangerous, as the eyes require time to adjust to the different lighting, and therefore vision may be temporarily impaired.

In transport routes sharp shadows can lead to accidents if lighting is inadequate. This problem exists in many workplaces.

## Reflection

Reflection is the ability of a surface to throw back light. The darker the surface the less light it will reflect and the more light will be required in the premises. Light reflected directly into the eye can cause glare.



*Glare from a low ceiling lamp, incorrectly positioned.*



*Indirect glare, the light is being reflected*

*The eye adapts to the brightness of light, in this case from the lamp or the reflection. The pupil of the eye is constantly contracted because of the bright light. On the right, the eyes must constantly adjust to the reflection. In both cases it is difficult to see the work material, and this causes fatigue and headaches.*

## Lighting requirements

Most of the light should fall on the material or objects that we are working with. The light source should as a rule be positioned behind and to the side of the left shoulder if the person is right-handed. This only applies to the actual lighting of the individual work station.

Among the factors important in determining the quantity of the light are:

- the nature of the work (e.g. more light will be required for precision work)
- the ability of the surrounding surfaces to reflect light
- the size, form and light-reflecting properties of the material or object, and whether the object is easily distinguishable from the background
- the eyesight of the workers.

### Points to remember!

- Lighting problems are a combination of light sources, glare, reflections and shades.  
(A simple rule of thumb)  
Good lighting requires light coloured walls!

### Discussion

- What can be done to make the best use of light through the windows- doors or skylight?
- Do you think you require more artificial lighting in addition to daylight?
- How are the lights positioned in relation to the work? Are there any shades that shadow the work?
- Are there any glare problems due to daylight? How about glares due to lamps?
- Do the older workers have an adequate amount of light?

## General and local lighting

Normally the lighting in a work premises consists of general lighting or a combination of general and local lighting.

- General lighting is lighting from ceiling or wall lamps. General lighting illuminates the entire premises.
- Local lighting is lighting placed near workers to give direct light to object(s).
- Combining general and local lighting allows the lighting to suit the worker and the work.

## Cleaning and maintaining lamps and fittings

The output of light decreases with the age of the light source. The most common reasons are:

- wear of the light sources (lamps)
- dirty fittings and/or dirty light sources
- dirt on the surfaces of the room
- dirty reflectors and dirty anti-glare devices.

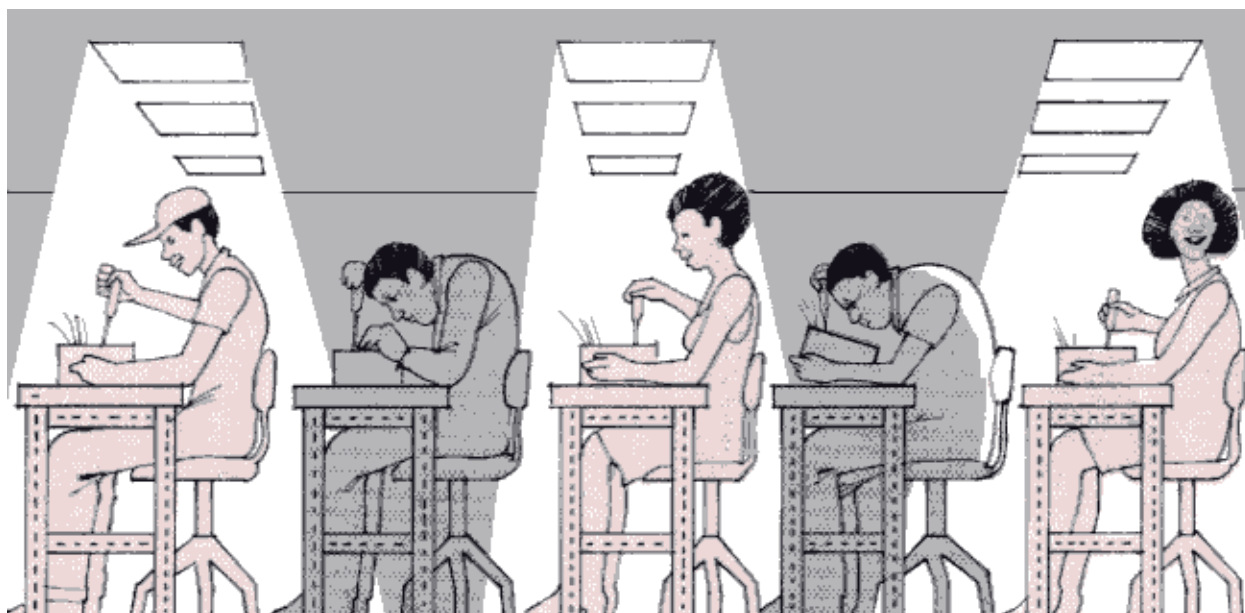

*Poor background lighting and the lack of local lighting causes unsuitable working positions and fatigue, and can also help lower productivity and the quality of the work. The background lighting must provide an even spread of light throughout the entire premises. The light intensity must be adapted to the work being carried out. Stronger light is always needed for work on small workpieces and components and precision work. In practice one way of arranging this is by fitting local workplace lighting. The colour scheme of the premises is also important. The floors, walls and ceilings should be painted in light colours.*

Dirt on the lamps and fittings is the biggest single reason for loss of lighting.

Lamps and fluorescent tubes grow old. After a period of time only half of the original light is produced. It is therefore not enough to replace lamps when they burn out. They should all be replaced when the lighting becomes inadequate.

Ordinary light bulbs usually have the shortest life and give off the least light. They usually last about 1,000 hours compared to fluorescent tubes which last over 7,000 hours.

Generally speaking, it is the type of work performed on the premises that determines how quickly the light fitting becomes dirty.

Also, for economic reasons, the lamps in the premises should be maintained on a regular basis. The required standard of lighting is more easily maintained if the lamps are cleaned and changed regularly.

### Points to remember!

- Regular service for lights is important. It also gives opportunities to think of better lighting.

## Discussion

- Who is responsible for keeping lights and windows clean?
- If a light bulb or tube fails who is responsible for replacing it?
- Are there any special tasks which require local lighting?
- Were any steps taken to improve lighting? Describe them.

## Effects of noise

Not all sound is noise. It is only *the sound that we do not like that we call noise*.

In recent years noise levels have increased. Machinery that has been made more efficient and faster has increased noise levels. In large open work areas, noise is widespread and can increase in intensity as additional machines add to the noise level.

The perception of noise is personal, however it is clear that any of us can have our hearing damaged, in some cases irreparably, if the sound level is too high.

It is not only *hearing* that can be affected by noise. Noise can also affect *blood circulation* and produce stress in the body. We then find it difficult to sleep.

*Noise can cause:*

- damage to hearing
- masking (disturbing to conversation)
- irritation or annoyance.



*We experience sound in different ways. What you find enjoyable and stimulating, other people may find noisy and unpleasant. Remember that every time you are exposed to a very loud noise you risk permanent damage to your hearing.*

**NOISE = UNPLEASANT SOUND**

**Injurious noise**

At many workplaces the level of noise can be injurious to hearing. Often the noise is created by different types of processing machines. Tools powered by compressed air, or manual work hammering metal objects also creates loud noise.

Noise which is continuous at a level of 85-90 dB(A) or more is injurious to hearing. You risk damage to your hearing if you spend more than five hours a day at this level of noise.

Hearing can also be damaged by sudden loud noises from an explosion near the ear. Unfortunately, you can't close your ears like you can do with your eyes.



*It isn't only direct damage from noise that affects us negatively. In stressful work situations, masking or irritating noise can give rise to mental stress which in turn can cause physical damage to our bodies.*

**Masking noise**

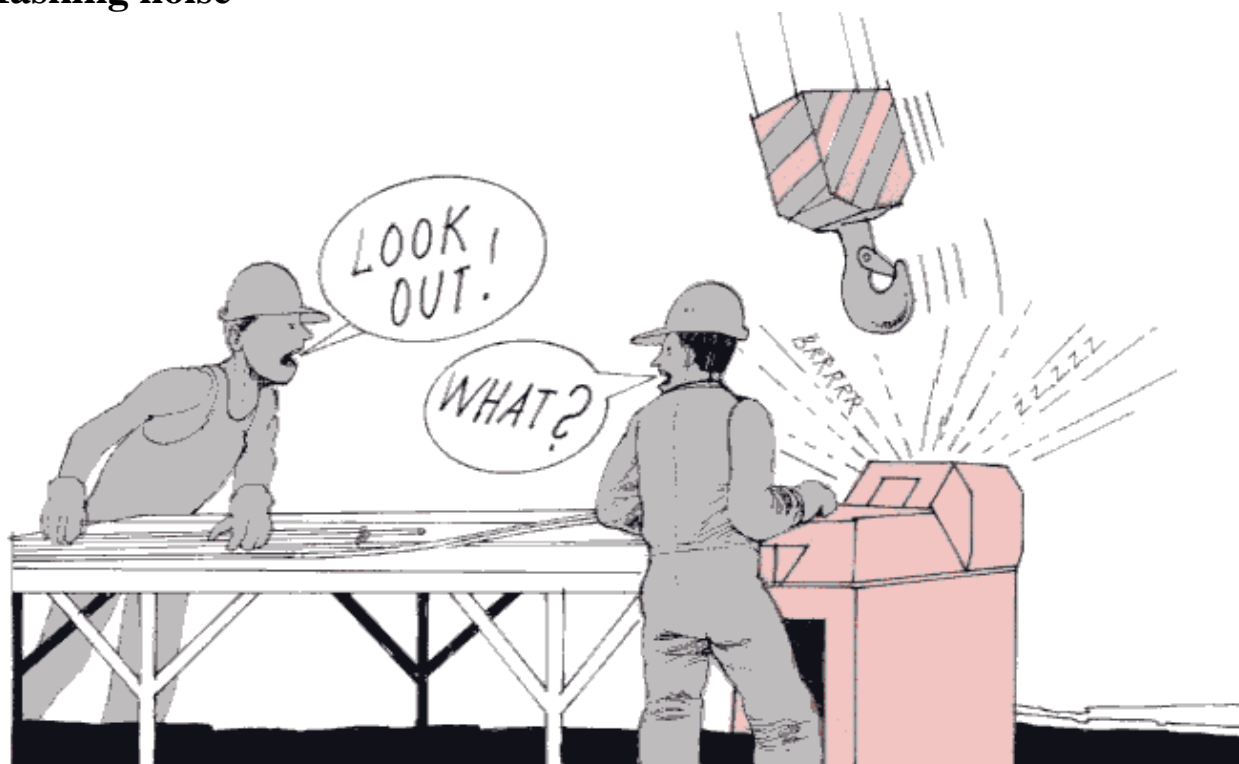



Masking noise means that the sound we want to hear is drowned by another sound. This can cause accidents, because warning shouts and other signals are not heard.

At a workplace the noise from machinery can mask the sound of a truck or disturb a conversation. Similar problems exist in most industrial workplaces.

The level of sound should not exceed 60-70 dB(A) if we are to conduct a *conversation at a normal distance*.

## Irritating noise

Irritating noise exists in various forms. The extent to which we feel that a noise is irritating is in part subjective, depending on our feeling as to whether the sound is desirable or not. Even a low volume sound can be irritating.

Restaurant patrons may enjoy music being played in the background while the waiters might find it irritating. We also frequently find this problem in the home, we can feel that our neighbour's music is irritating while he thinks that it is wonderful.

## Discussion

- At work, is it sometimes difficult to hear what people say?
- Discuss noise sources which disturb you most while working.
- Do you feel that there are levels of noise which are injurious to hearing?

## Injury to hearing

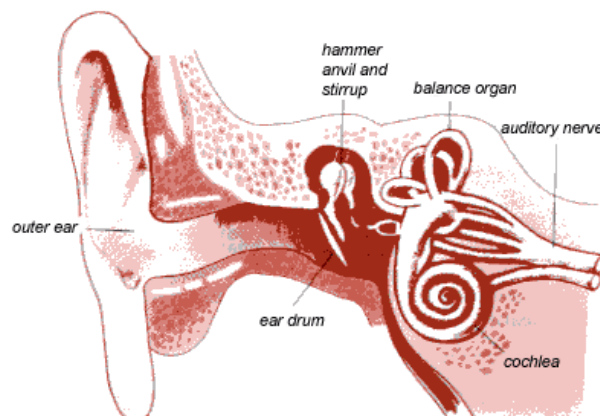

Long periods spent in areas of high noise levels can result in a measurable deterioration in hearing. The ear is a highly sensitive organ that we must protect.

The upper picture shows a cross-section of an ear. Sound travels through the outer ear, and causes vibrations of the ear drum and the three ear bones (hammer, anvil and stirrup). The vibrations pass through the fluid contained in a tightly coiled tube called the cochlea. The auditory nerve which has endings in the cochlea transmits the signal to the brain.

It is the cochlea which is damaged when we are exposed to an excessively high sound level. The very fine nerve endings in the interior of the cochlea are damaged and die. This damage is irreversible. It cannot be repaired.

Individuals have different degrees of sensitivity to noise. Some people's hearing can be damaged faster than the others.

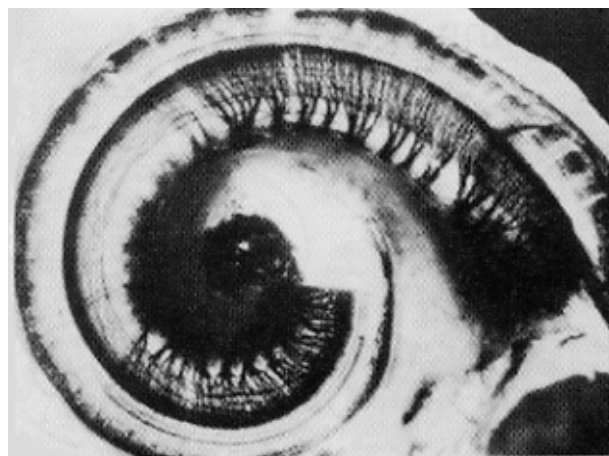
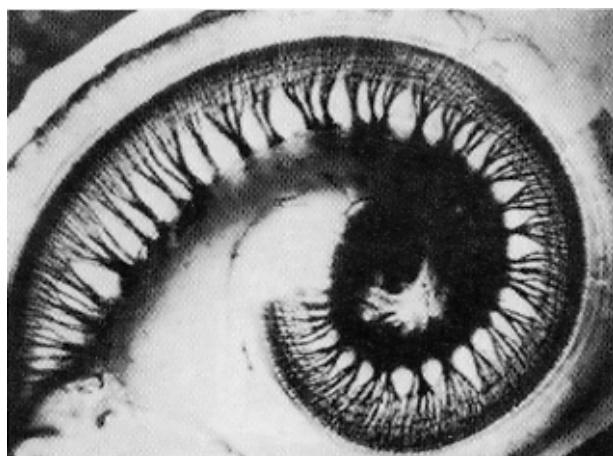

*A cochlea damaged by noise. About one-third of the nerve endings have been totally destroyed. This makes it impossible to hear high tones – a hearing injury.*

## Temporary noise-induced hearing loss

There is one warning sign that we must heed: if after a short time in a noisy environment we leave it for a quieter one and do not at first hear the quieter sounds, our hearing has been reduced – this is called temporary noise-induced hearing loss. This kind of loss is reversible. Normal hearing will return after a period of rest.

It is therefore important that those who spend time in noisy workplace be allowed to rest their ears by taking a break in quiet surroundings.

Temporary noise-induced hearing loss is a warning sign. You must avoid working for many years in such an workplace to avoid permanent hearing loss.

## A handicap

Hearing is an important sense which helps us establish contact with our surroundings. If we permanently or partially lose our hearing, we will find it difficult to hear what other people are saying and difficult to listen to the radio or TV.

Partial or total hearing loss can have the following consequences:

- you may find it very difficult to understand normal speech

- you may have difficulty in understanding what supervisors or workmates say and in recognising sound signals
- you may suffer from a feeling of isolation as you cannot participate in discussions during breaks or conversations with friends during time off
- you may need more rest and relaxation than normal because you must often use all your energy to do your job.

### Points to remember!

- The ear can tolerate low tones more easily than high tones. Consequently, if the ear is damaged, it is the perception of high tones which disappears first. We must not notice this because we can hear normal speech. It takes several years before the damage becomes so apparent that we have difficulty in understanding what other people say.

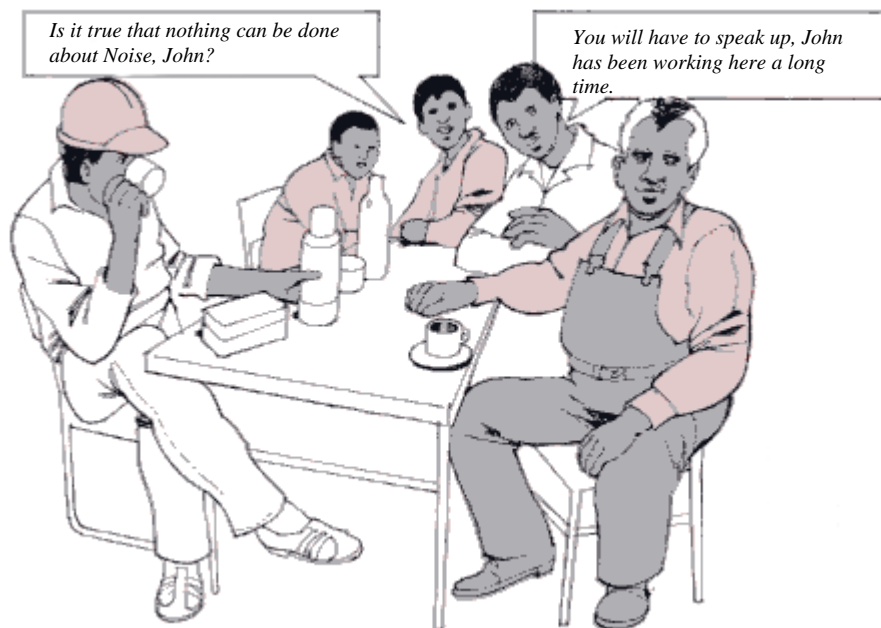



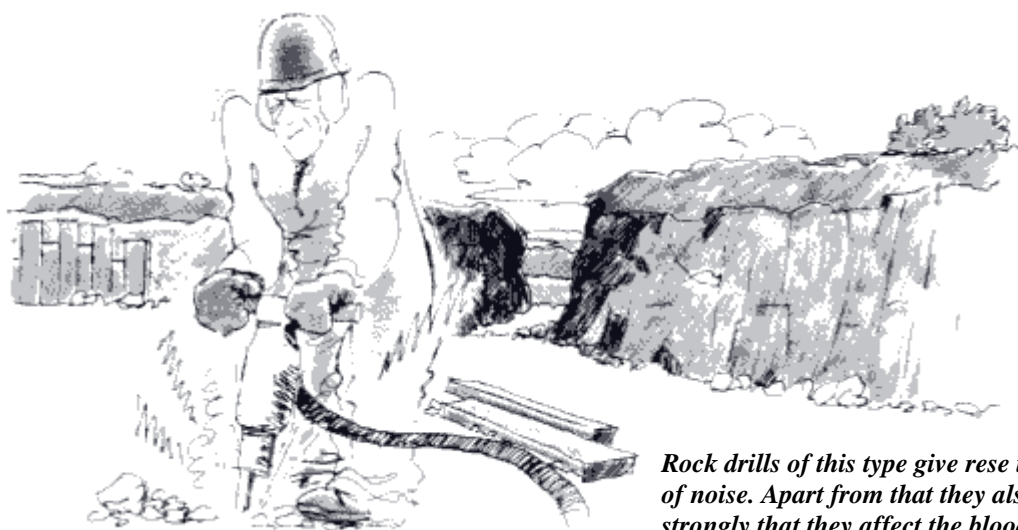

*Rock drills of this type give rise to a very high level of noise. Apart from that they also vibrate so strongly that they affect the blood circulation and injure muscles and joints.*

## Vibrations combined with noise

Noise stems from vibration or flowing gases or liquids. Many machines or power-driven hand tools also transmit their vibrations to the human body. They can injure muscles and joints and affect blood circulation. “White finger disease” seen among workers using pneumatic drills or chain-saws is a painful example of vibration injuries.

Whole-body vibration is also a problem. A vehicle operator who sits for lengthy periods on a seat or on a forestry machine is subjected to strong vibrations. In this case, the frequency of the vibrations are much lower, although they are accompanied by the loud noise of the engine. The vibrations a forestry machine operator receives can cause considerable discomfort and even damage to internal organs.

### Discussion

- Do you or any of your workmates suffer from partial hearing loss or deafness?
- What problems can deafness cause at work? What problems can deafness cause when not at work?
- Hearing loss due to machine noise has long been known to us and is still a problem. How do you feel about it? Do you accept it as an inevitable evil?
- What are the bad effects if a workplace is too noisy? Make a list of possible effects on health and possible effects on safety.

## Decibels

Sound may consist of one pure tone but mostly it is a mixture of many tones of different volumes (loudness) and pitches (high or low frequency). The volume is measured in decibels (dB). The pitch is measured in hertz (Hz).

If we find a sound disturbing it is not simply due to its loudness. The pitch can also be a contributing factor. High tones irritate more than low tones. Pure tones may be disturbing and can cause more injury than complex sound.

The table below shows the volume of different sounds expressed in dB(A). dB(A) is normally used because this corresponds most closely to the effect of noise on the human ear.

### The characteristics of the decibel scale

Noises from different sources blend together. The level of total noise in any area increases with the number of sources of noise. Because of the peculiar characteristics of the decibel scale (a logarithmic scale) we cannot simply add up the different noise levels. Two different sources of noise which each creates a noise level of 80 dB(A), together give a decibel count of 83 dB(A) – *not* 160 dB(A).

Another important characteristic is that a change from 80 dB(A) to 83 dB(A) is experienced by the ear as just as great as a change from 40 dB(A) to 43 dB(A).

A change of 3 dB(A) – as in this example – always has *the same effect* on our experience of noise regardless of the initial noise level.

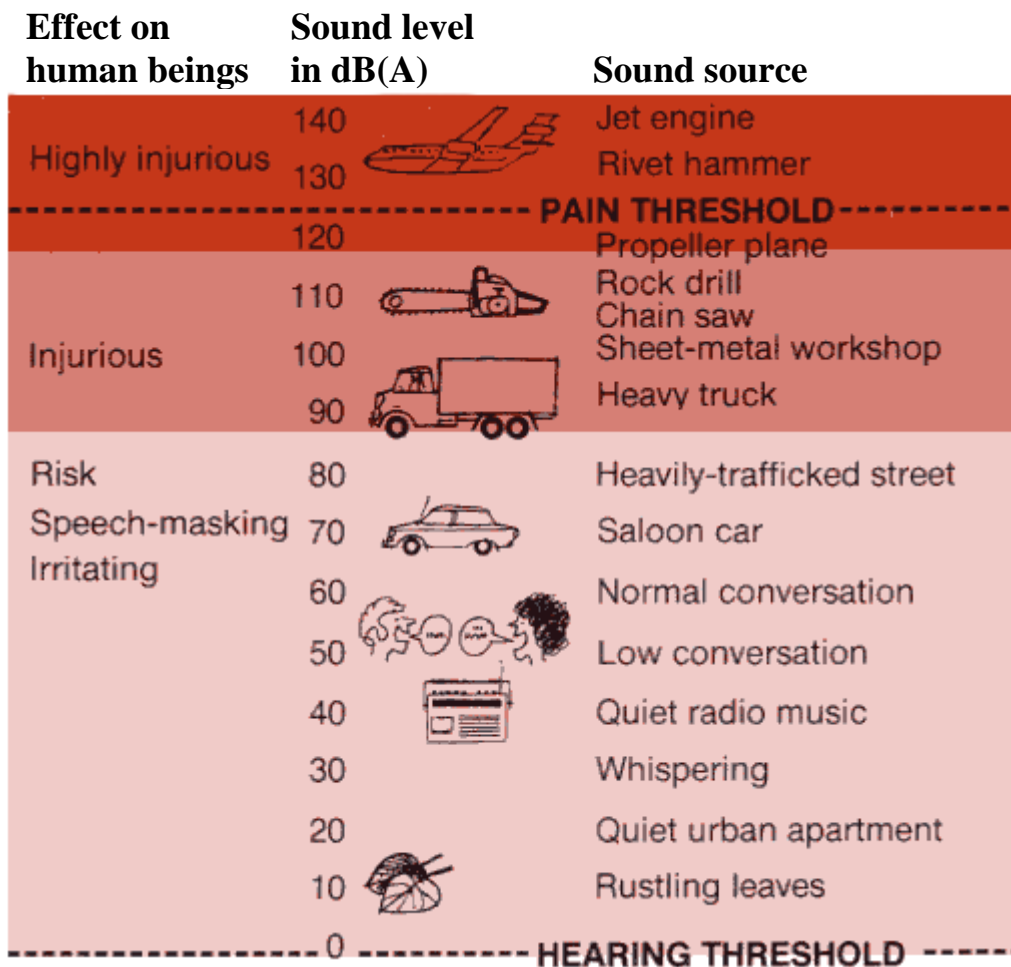

It is important to bear these facts in mind when discussing the intensity of noise and changes in noise intensity. Saying that the noise level has been cut *from 90 dB(A) to 80 dB(A)* doesn't sound very significant, but with the particular characteristics of the decibel scale in mind, it means that such a reduction is the same as the effect we get in a workplace if *we remove nine out of ten noisy machines*.

**Points to remember!**

(A simple rule of thumb)!

- If you are unable to speak in a normal tone of voice standing at arm's length from your workmate then the noise level is too high.

**Discussion**

- List the sources of noise which affect you.
- For particularly noisy sources, can you identify which machine components or elements are the main sources of such noise?
- Can the noisy work at your workplace be separated from the quiet work?

**Methods of noise control**

**1. MACHINERY AND PRODUCTION PROCESSES**

Many sources of noise produce both air-borne and structure-borne sound. We must, therefore, try to reduce the level of noise both from the machinery and on the work premises.

It can be difficult to reduce the amount of noise produced by machinery and production processes without interrupting or reducing production. However, try to:

- *enclose* entire machines, or particularly noisy parts of machines
- *service* the machines regularly to keep them in good condition and thereby reduce the noise
- *reduce* the vibration in component parts and casings, etc.
- *replace* metal parts by parts made of sound-absorbing material, e.g. plastic, rubber or other soundproof materials
- *lengthen* the braking period for reciprocating parts.

**Noise-insulated air compressors. The principle is that the noise should be contained under the hood. The hood is made of hard material with a soft, absorbent lining.**

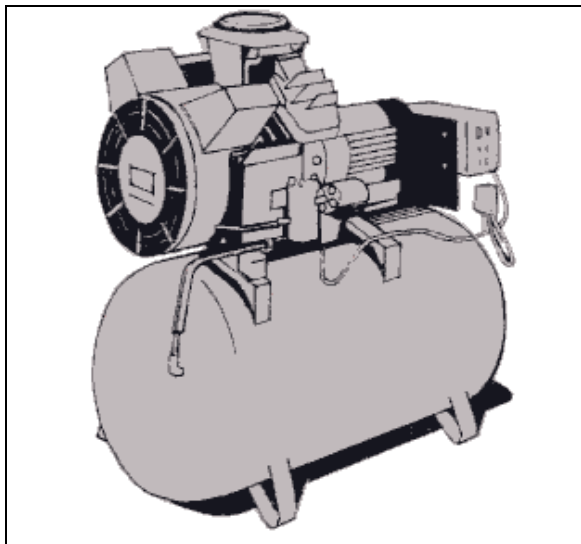

A well designed soundproof casing can reduce the noise level up to 55 dB(A). If the level of noise in a workplace is higher than 80 dB(A), steps must be taken to reduce the overall noise level. This can entail the construction of soundproof casing around the machines or the use of personal hearing protectors. Building a soundproof cover around the noise source or similar measures is preferable to relying on hearing protectors. However while waiting for such improvements, always use hearing protectors.

*1.5 mm stiffened plate  
reduce  
vibrations*

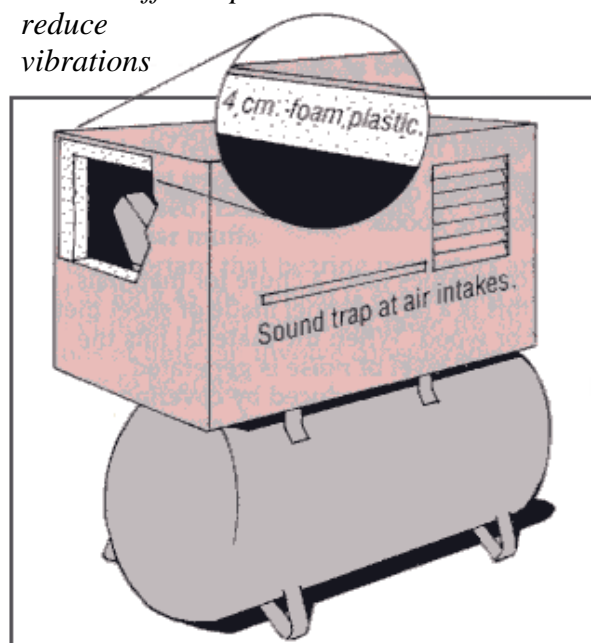

## 2. NOISY EQUIPMENT

Noise from equipment can be reduced efficiently without taking complicated measures. Examples of methods are:

- fitting* a screw-on muffler on the exhaust outlet
- changing* the type of pneumatic equipment to reduce high-frequency components
- replacing* the equipment with a quieter model e.g. quieter fans with proper blades
- properly fastening* some noise-producing parts
- isolating* or screening the workplace containing noisy equipment.

## 3. MATERIALS HANDLING

Noise generated by the handling of materials can often be reduced. Avoid banging and knocking materials during handling, particularly transportation equipment.

Remember also to:

- reduce* the height that goods in bins and racks can fall
- reinforce* sheet metal constructions that are hit by packets or materials or cover them with sound-proofing sandwich sheets or similar materials
- reduce* sharp blows by using rubber or plastic coverings
- reduce* the speed of the conveyor systems
- install* several conveyor belts to divide the load and thereby reduce the speed.

*Another method* of reducing the noise level in transporting goods:

Many companies have a chute for materials. As a rule this is a large funnel made of sheet metal, plastic or wood. When the material hits the chute a high level of noise is generated.

The noise can be reduced by covering the outer surface of the chute with sound-proofing material. When purchasing a new chute, make sure it is of a sandwich type construction.

The following example shows how steps can be taken to reduce the level of sound resonance, i.e. sound which is amplified through contact with e.g. discs and wheels.

The conveyor belt is constructed so that it can be lowered or raised with a hydraulic system. The end of the belt has a drum attached to it with rubber breaking blocks attached to the insides of the container. The drum is automatically raised. The free fall height is always the same as the difference in height between the fast rubber breaking block and the top level of the materials or objects in the container.

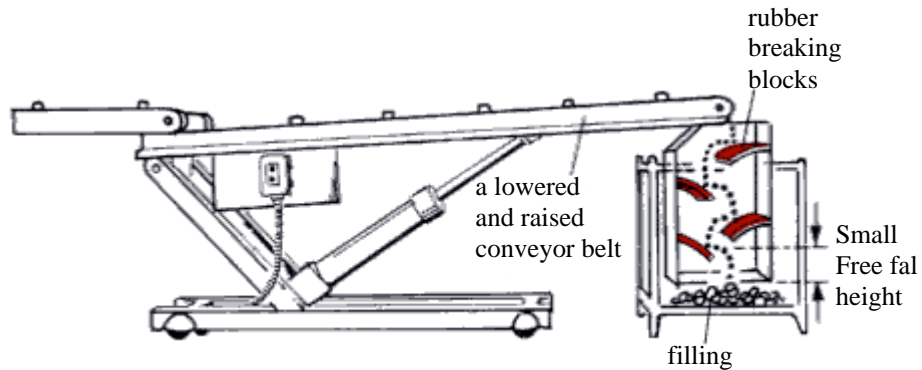

#### 4. WORK PREMISES

The distribution of sound on the actual work premises can be reduced by:

- covering the ceilings and walls with sound-absorbing materials (porous material)
- using sound-absorbing screens
- building sound-proof control areas and rest rooms.

Installing sound-proof material in the ceiling lowers the general level of sound on the premises. The baffles in the picture above are often replaced nowadays by sound-absorbing ceiling panels.

If the noise sources are isolated by a wall or enclosed in sound-proofing casings the noise level can be reduced both near the source of the noise and further away. Those people who are working at quieter jobs with quieter machines are not then unnecessarily disturbed by surrounding sources of noise.

By covering the ceilings and walls with sound-absorbing materials, the distribution of the sound on the premises can be reduced and the level of noise lowered.

It is often necessary to place machinery which creates noise on elastic pads or feet. This isolates the vibrations and prevents them from being distributed through the structure of the building, ducts, pipes, etc. Large, heavy machinery should be placed on individual foundations separated from the main workshop floor.

#### EXAMPLE

*In a car plant with several different productions lines the noise from one line is higher than from the others. The grinding work on the undercarriages creates a screeching high frequency sound, which disturbs everybody working in the main hall.*

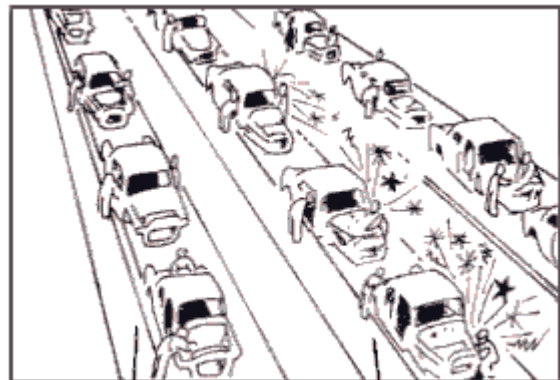

Line with low noise level

Line with high noise level

#### Points to remember!

- In practice, a combination of the following noise reduction methods are usually used:
  - reducing the level of generated noise
  - screening the source
  - absorbing noise
 Often reduction of generated noise may be too expensive, and other methods must be used. For example, we might use enclosures with porous absorbers.

#### Discussion

- How would you decide whether the workplace is too noisy?
- Have any of the suggestions made in this section been applied to machinery?
- What steps are necessary now to reduce the noise levels?

**MEASURES**

*Putting up fight partitions along the sides of the production line and hanging sound absorbing baffles over the opening above, cuts off the other production lines from the grinding noise. But you still have to use protectors hearing.*

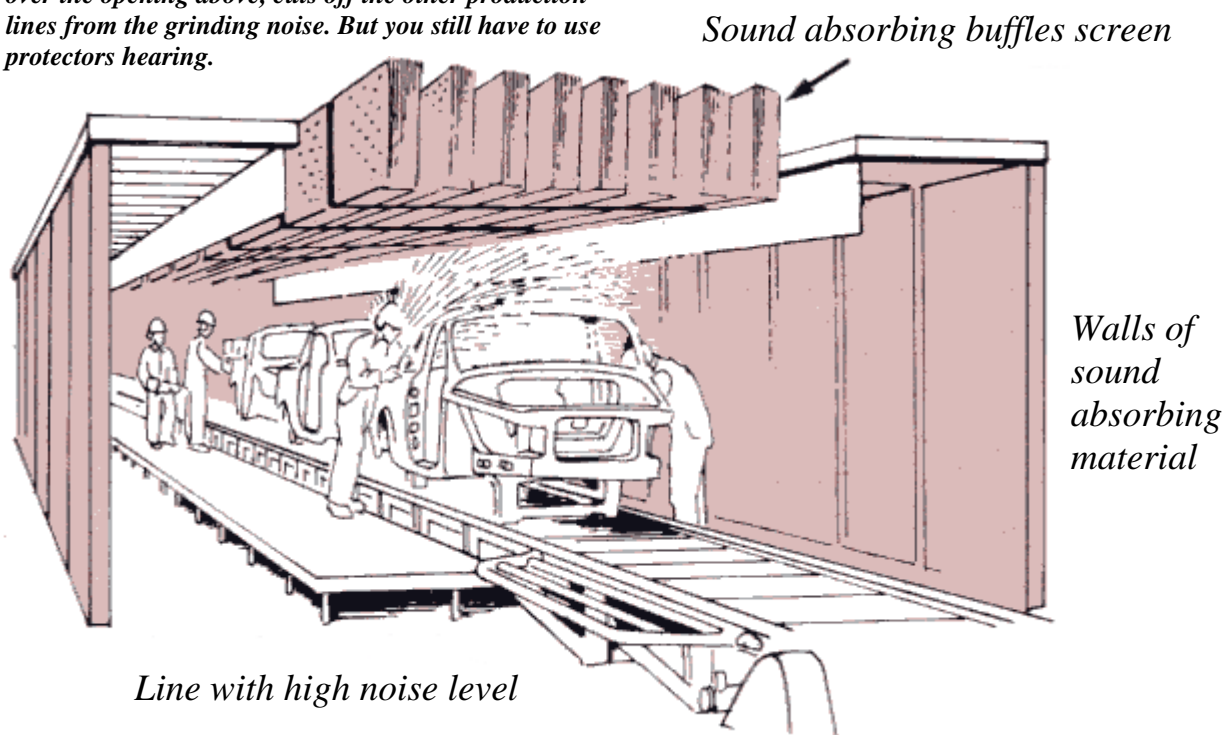

## Hearing protectors

### **EAR PLUGS, EAR MUFFS**

Noise which is injurious to hearing should be dealt with by technical measures. If this is not possible then personal protective equipment should be used. Examples of this are use of ear plugs and ear muffs.

It is important that hearing protectors are used as long as the person is exposed to a high level of noise. Even removing them for short periods of time can involve considerable risk of damage to hearing.

### **Points to remember!**

- If ear plugs or ear muffs are to be used, they should be thoroughly tested. To be effective they must provide a good sealing effect. Also note that loosely inserted ear plugs or a worn muff will not protect your hearing. Plugs and muffs must be regularly cleaned and repaired or replaced. Full co-operation of supervisors and workers is necessary to ensure the consistent use of ear protectors.

### **Discussion**

- Are there any hearing protectors provided?
- If so, are they used? Are they cleaned regularly?
- Do you think there are some jobs for which the use of hearing protectors should be obligatory?
- Why do many workers not like using hearing protectors?



*Disposable earplugs.*

- 1. Formable wedging – acoustical fibres.*
- 2. Plastic covered acoustical fibres.*
- 3. Expandable plastics.*
- 4. Reusable plastic earplugs.*

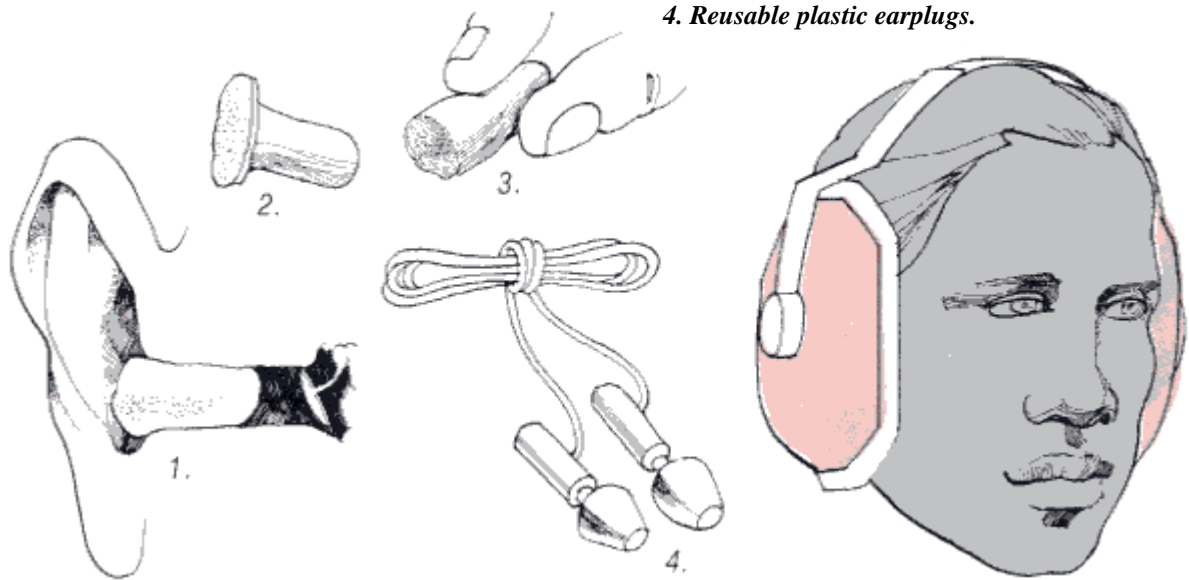



# USEFUL HINTS

## Heat and ventilation

- There is enough natural ventilation through windows and openings.
- Radiation from roofs and walls are minimised by using the appropriate materials and colours.
- There is good ventilation near the roof or ceiling.
- An adequate number of ventilators provided to keep workplace air clean and comfortable.
- Air is circulated by electric fans in hot workplaces.
- Hot surfaces are insulated as far as possible.
- There are barriers between the heat source and the workers.
- Where necessary, heat protective aprons or clothing are used.
- Where air conditioning is used, an appropriate type is provided taking due account of possible air pollution resulting from work processes.
- Overcooling or uncomfortable draughts by air-conditioning is avoided.
- Heavy physical work in hot workplaces is reduced as much as possible.
- Work in confined areas in a hot temperature is avoided.
- Sufficient breaks are provided in work in a hot temperature.
- Cold drinking water is available near the workplace.

## Noise

- Noisy parts or machines are enclosed or covered completely.
- Machines are regularly serviced to avoid increased noise.
- Sound-absorbing materials are used at ceiling, walls or machine covers.
- Noisy equipment or its parts are replaced with quieter models.
- Adequate screens are used to prevent propagation of noise.
- The height of objects in containers is minimised to avoid falls of great distances.
- People working with quieter machines are not unnecessarily exposed to noise from other machines.
- Workers in most noisy workplaces are rotated to avoid long hours of exposure.
- Transmission of vibration from machines to hands is damped as much as possible.
- Ear-plugs or ear-muffs are used where the noise level reaches or exceeds 85-90 dB(A).

## Lighting

- Enough daylight reaches worksites without being shadowed by obstacles or wrong worksite positions.
- Skylights are used to increase daylight.
- Light colours are used for walls.
- Glare at work does not occur from ceiling lamps or spot lamps.
- Glare from strong reflections is avoided.
- Shades of too strong contrast are avoided.
- General lighting is adequate to the type of work done.
- Spot lamps are used to supplement general lighting, especially for precision work.
- All lamps are changed regularly.
- Lamps and fittings are cleaned regularly.

# CHEMICAL RISKS TO HEALTH

*“Every day we are exposed to different types of chemicals in the home and at work. There are estimated to be approximately two million chemical compounds. Only a small number of these have been tested thoroughly regarding their dangerous properties. Chemicals should therefore be treated with the greatest care.”*

## Inspection and control of chemicals

The inspection, control and handling of chemicals must be on-going in order to protect workers from injury.

We all must increase our knowledge of the chemical risks in the workplace, in particular with regard to the possible long-term effects of chemicals. Many current cases of occupational cancer have their origins in working environments two or more decades ago.

This section will look at how different chemicals and different methods of handling them can affect us, and examine what measures should be taken to ensure effective protection.

The subjects covered are:

- chemicals and their risks
- atmospheric pollution
- gases
- liquids and vapours
- metals
- exposure limits
- preventive measures
- personal protective equipment.

## Chemicals and their risks

### HOW WE ARE AFFECTED

We are exposed to chemicals in different ways, for example:

*A chemical can cause injury in several ways:*

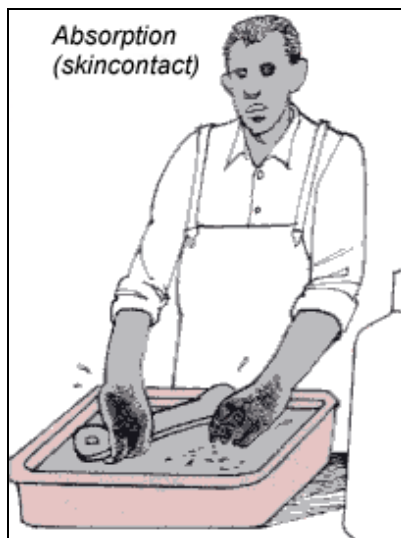

Our body has a considerable capacity to purify dangerous substances. It is primarily the liver and kidneys which do this work, but if the body is exposed to a chemical over a long period of time our defences can no longer render it harmless. The substance is then stored in the body and can cause various medical problems. Lead and cadmium are examples. It takes a long time for the body to break down lead and, in the case of cadmium, there is no breakdown at all.

## Acute – chronic condition

There is a difference between acute (short-term) and chronic (long-term) conditions.

An acute condition is often discovered quickly and has short-term effects. The common symptoms are dizziness, headaches, vomiting.

Solvents are typical substances which can produce these acute effects. They act rapidly on the body and for the most part produce effects which are of a passing nature. Solvents can, however, have both acute and chronic effects on the nervous system.

Chronic conditions may result from exposure to dangerous substances over a long period of time. Asbestosis, a lung disease, is an example of a chronic condition.

Both acute and chronic conditions can result in permanent injury. However, the injury can be only temporary if steps are taken to ensure that the person does not come into contact with the substance again. The extent of the injury depends on dangerous health characteristics of that substance.

## Discussion

- Explain some typical symptoms of acute and chronic conditions. Distinguish between them.
- Have you known any worker who suffered from any of these symptoms? What happened?

## Some main categories

From a practical standpoint the main chemical risks to health can be divided up into:

- atmospheric pollution (dust, fumes and smoke)
- gases
- liquids and vapours (solvents, acids and alkalis)
- metals (lead, nickel, chromium, etc.)
- chemicals causing contact dermatitis.

## A. Atmospheric pollution

### AIR-BORNE PARTICLES

There are many substances at our workplaces which are suspended in the air in the form of particles. The body can reject or filter out the larger particles through the nose and the mucous membrane (thin tissue) of the respiratory tract which catch many of the particles. They are either coughed up or swallowed. The lungs also contain cells which to some extent remove particles that are inhaled.



The ability of the body to render inhaled particles harmless depends upon:

- the size of the particles
- the nature of the particles
- the quantity of the particles
- the time spent in that workplace.

The smaller the particles are, the further into the lungs they reach. Some dust can even enter as far as the tiny air spaces which make up the air sacs, thousands of which form a lung.

The chemical composition of the substance is also of great importance. Particles of some metals or metal alloys can damage the body's internal organs. Some examples are lead, manganese and chromium.

The concentration of the particles, (i.e. the amount of dust and smoke present on the work premises) is one of the key factors determining the extent of the risk.

Another vital factor, in addition to the amount, size and nature of the particles, is the length of time one spends in the work.

Smoking and other activities which reduce the body's resistance to illness increase the risk of injury.

## DUST

Dust, fumes and smoke are the most common types of air-borne particles found in workplaces. They are formed when working with different materials.

Inhaled dust accumulates in the lungs and causes a tissue reaction. This lung disease is called "pneumoconiosis". It is still the most common incapacitating occupational disease. Continued exposure to the dust increases the affected area of the lung and its breathing capacity is damaged. The air sac structure of these areas may deteriorate into 'fibrous' form and remain there as a permanent scar in the lung. Breathlessness and inability to work may result after many years of exposure to dust.

Once fibrous changes develop in the lung, the air space is permanently destroyed. These changes are incurable. Examples of pneumoconiosis with various effects on the lung are silicosis caused by quartz dust and asbestosis, caused by asbestos dust. Many other forms of pneumoconiosis are also known. It is therefore vital to protect workers from high dust concentration. Dangerous dust can also arise from unpaved roads and upswept factory floors.

Quartz dust is produced when processing certain types of rocks. Silicosis is a possible consequence of exposure to quartz dust over a long period of time. This disease is characterised by a slow destruction of the lung tissue making it difficult to breathe. Many people have died from silicosis. Silicosis facilitates the development and spread of tuberculosis.

*Asbestos* is fibrous silicate used in various materials, e.g. insulating material for protection against heat and fire, building materials (walls, ceilings, etc.), sealing components in the undercarriage of motor vehicles,

*Asbestos fibres can be compared to barbed spears which penetrate the tiny air spaces of the lung.*

*Inhaling asbestos fibres increases the risk of lung damage and can also cause various types of cancer.*

*The needle-sharp asbestos fibres penetrate the deepest parts of the lung, the alveolar sacs, where they lodge.*

*Macrophage cells trying to surround an asbestos fibre and render it harmless. Instead, the asbestos fibre destroys the macrophages one by one in a 'perpetual' sequence.*

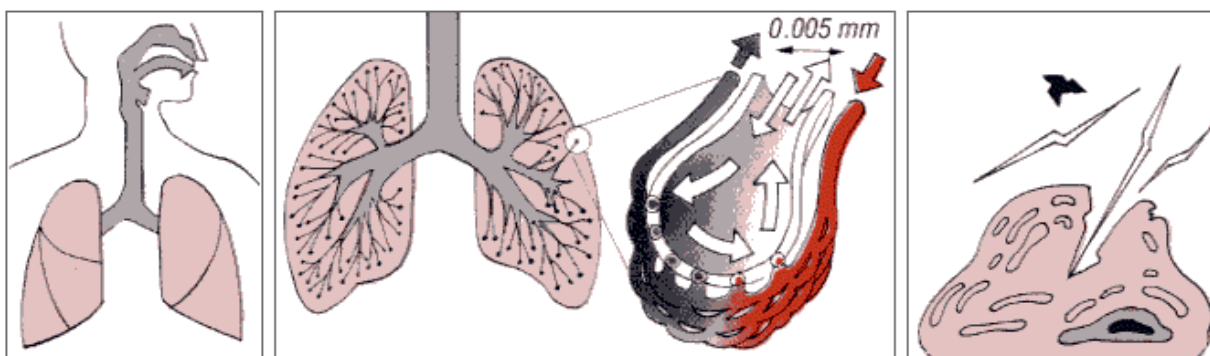

rubber seals, etc. Asbestos dust consists of thread-like fibres which penetrate the lungs and destroy the lung tissues. Fibres which penetrate the lungs remain there for the rest of the person's life. Asbestos dust can cause the disease, *asbestosis*. This develops in the same way as silicosis. It can take decades before the first symptoms are noticed, including considerable difficulty in breathing. In many cases asbestosis can cause cancer of the lungs or air sacs.

Surveys carried out in the USA show clearly that there is a great danger of developing cancer as a result of exposure to asbestos. The risks are particularly high in combination with smoking.

Asbestos is used in several countries around the world, despite its danger to health. However, its use has been restricted in several industrialised countries due to the considerable risks of cancer. Discussions are taking place in many countries on limiting or prohibiting the use of asbestos. The use of asbestos should be forbidden all over the world due to the risks of lung cancer, stomach cancer, cancer of the bowels, cancer of the throat and the tumor illness called mesothelioma.

## FUMES AND SMOKE

Fumes and smoke are also inhaled and can cause damage to the body. They are formed when various materials are exposed to intense heat, as in welding. For example, zinc and some other metals, when inhaled in a large quantity, are known to cause "metal fume fever" which develops about half a day after exposure.

**WHERE IS ASBESTOS TO BE FOUND?**

*Asbestos is often present in buildings and ships and as fire protective, sound and heat insulation, and as a filler in cement and plastic. Its other uses include brake and friction-plate linings in vehicles, machines and hoists.*

*Mining, processing, demolishing and other processes involving asbestos releases airborne dust which contains needle or thread-shaped asbestos particles. It is these free fibres that are a direct health hazard.*

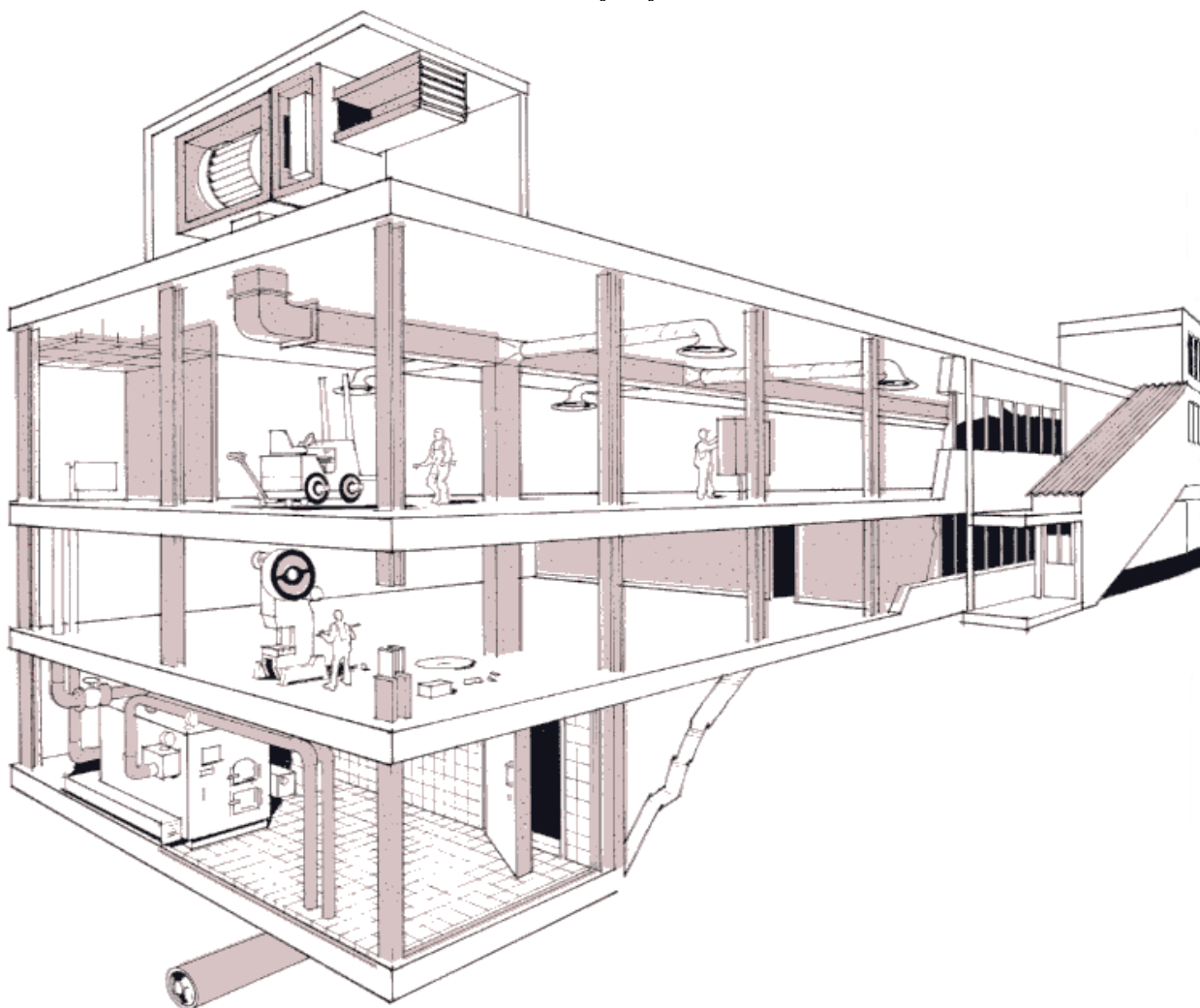
**WHERE ASBESTOS IS PRESENT**

*Industrial premises with both office and workshop divisions. The following items contain asbestos:*

- *Intake air ventilation (on roofs) with sound baffles and heat exchangers.*
- *Asbestos cement board*
- *Fire break walls, fire doors*
- *Heating and sanitary installations with furnaces, piping and gaskets (in cellars)*
- *Fire protection on steel beams*
- *Spark shields in electrical junction boxes etc.*
- *Tile adhesive*
- *Paint and glues*
- *The backing of plastic carpeting.*



## B. Gases

Some gases and vapours have a sharp or irritating smell. This smell is an early warning signal. The gases which do not give a warning signal or which rapidly reduce our ability to realise or assess the danger are even more dangerous. Gases may spread into the workplace air through various chemical processes or through leakage from gas cylinders.

Normally a distinction is made between two types of gases:

- irritant gases, which have a corrosive or irritating effect on the breathing organs;
- gases which are absorbed by the blood and affect the internal organs.

Chlorine and sulphur dioxide are examples of irritant gases. A high concentration of these in the air can damage the lungs.

Other irritant gases are phosgene and the nitrous gases. They do not provide a warning signal in the form of irritation when breathing. Phosgene is formed when e.g. trichloroethylene or tetrachloroethylene come into contact with hot surfaces or naked flames. Nitrous gases are formed when the oxygen and nitrogen in the air are heated intensely, as in welding.

Carbon monoxide, hydrogen sulphide and radon are examples of gases which affect the internal organs. Carbon monoxide is a colourless and odourless gas which combines with the oxygen-carrying elements of our blood faster than oxygen can. Exposures to certain levels of carbon monoxide may result in acute medical conditions and death.

A word of caution is necessary about the *lack of oxygen* that can occur in confined spaces (silos, tanks, reaction vessels, air-tight compartments, etc.). This is a very dangerous situation and can rapidly kill. Oxygen may be removed from the air by, e.g. excessive carbon dioxide due to fermentation, slow oxidation during rusting, etc. Setting up and enforcing proper procedures is absolutely necessary for working in confined spaces.

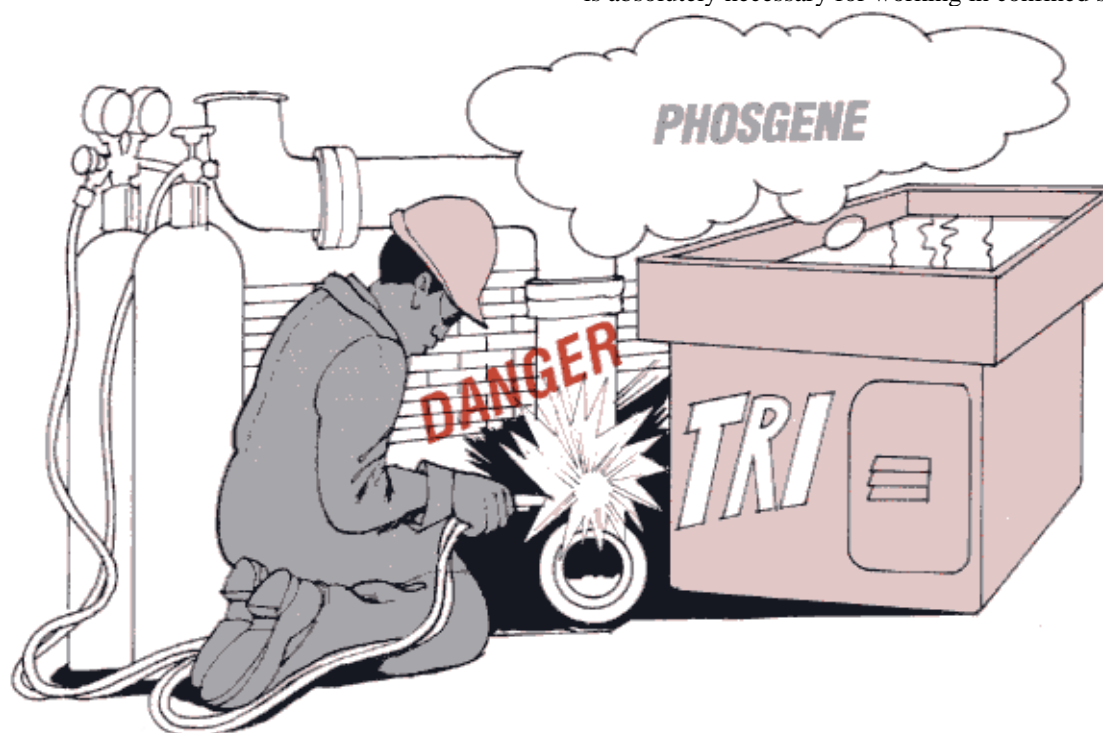

### Points to remember!

- Hazardous dusts, fumes, gases and vapours are invisible. Dusts seen in the sunlight, for example, are large particles which are caught before reaching the lung. Careful assessment of air pollutants is essential for prevention.

### Discussion

- State the processes where you notice the most dust.
- Do you think it likely that this dust is harmful to health?
- Can you think of any places where dangerous gases might be formed?
- For such places, what remedies can you take?



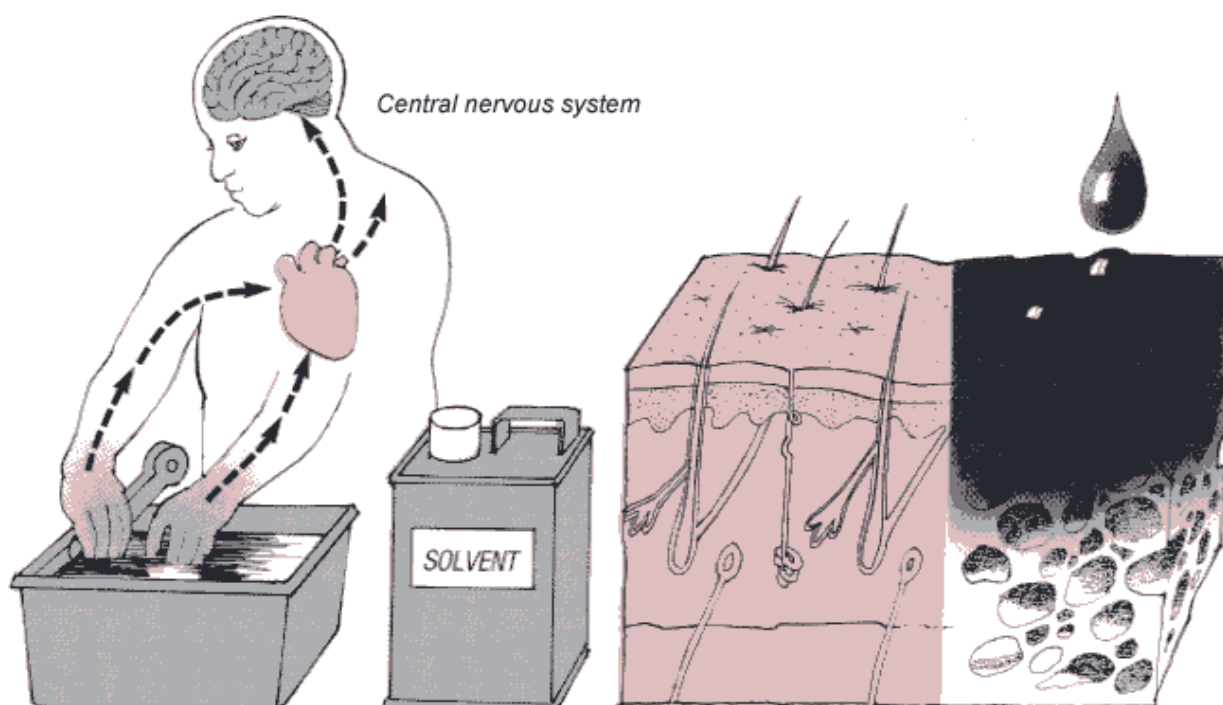

*Solvents can reach the brain both through the lungs and through the skin. The brain's cells contain a lot of fat and therefore attract fat-dissolving substances.*

## C. Liquids and vapours

### SOLVENTS

One of the most common risks to health in working life is caused by vapours and splashes from solvents. Solvents have the ability to dissolve other substances, particularly greases and fats. Furthermore, they evaporate rapidly.

When a solvent evaporates, the vapour becomes part of the air that we inhale. It then travels through the blood to the internal organs, e. g. the brain and liver. Because solvents can dissolve substances they can also affect mucous membranes and the skin. Some solvents can even be absorbed through the skin, though the majority are inhaled.

The greater a solvent's ability to dissolve greases or fats, the greater the effect it will have on the central nervous system.

Dizziness, headaches, tiredness, reduced comprehension and prolonged reaction times are some of the symptoms of short exposure to solvents. Although these effects may disappear quickly they increase the risk of accidents.

For a long time it has been known that solvents which are absorbed and stored in the body have the

same effects as an anaesthetic. In fact many solvents were previously used as anaesthetics, intoxicating people and putting them to sleep. In extreme cases the effect of the anaesthetic is loss of consciousness and death. Some of them have a very low viscosity, and the concentration in the work premises can easily rise to very high levels if the solvent is not handled properly. Vapours from solvents containing chlorine can produce phosgene and hydrogen chloride when they come into contact with hot objects.

### Points to remember!

- The ability of a solvent to cause injury includes the following factors:
- the viscosity of the solvent: low-viscosity solvents spread more rapidly in enclosed areas
- the concentration in the air: the amount of solvent in the atmosphere can be checked by using measuring devices
- exposure time: the longer the exposure time, the greater the risks of injurious effects.

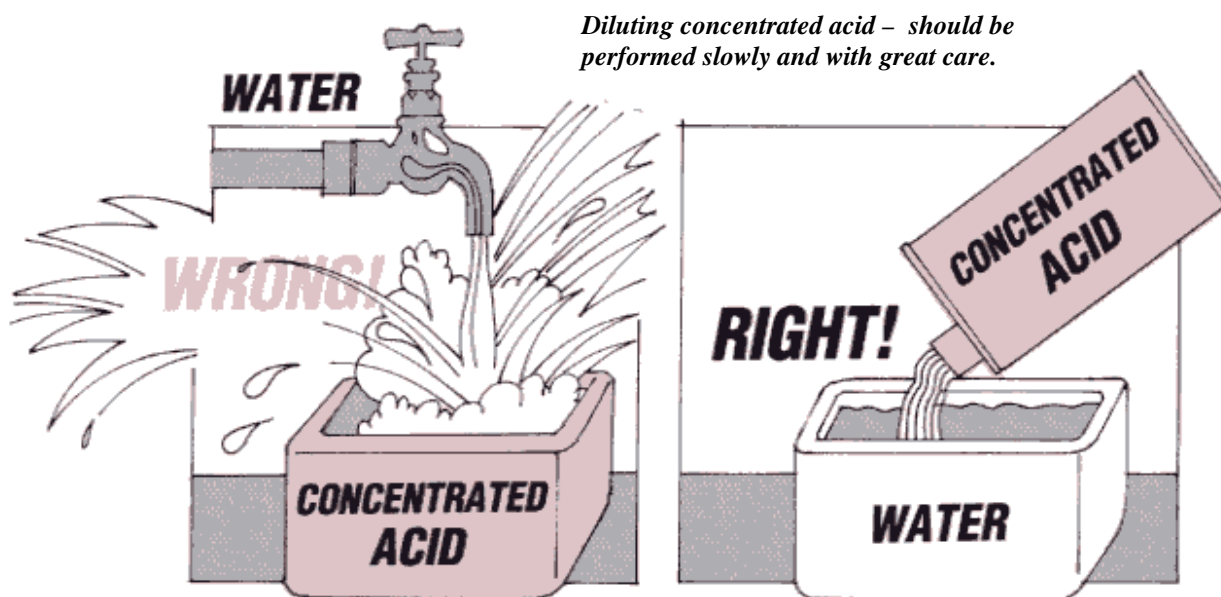

## ACIDS AND ALKALIS

Acids and alkalis are corrosive substances which can damage the skin and eyes on contact.

A corrosive mist can form above acids and damage the respiratory tract and lungs. Especially dangerous acids include hydrochloric, sulphuric, chromic and nitric acids.

Among other things, alkaline substances are used to clean grease from metal objects. Soda lye (caustic soda) and ammonia are examples of alkalis.

Contact with the skin can cause serious burns unless large amounts of water are used to rinse the substance off.

## Discussion

- Are any solvents used at your workplace? What are they used for?
- Are they stored and labelled properly?
- When acids or other strong liquids are used in any manufacturing process or for cleaning, what instructions are given to the workers?
- Have any of the workers dealing with solvents, acids or other strong liquids shown any symptoms or have there been any complaints about these materials?

## D. Genetic effects

The risks to health in the workplace which can result in adverse genetic effects are difficult to detect. Exposure of men and women to different chemicals over a long period of time can cause serious birth defects to their

unborn children. The effects of this exposure are often difficult to detect immediately, and therefore we should be increasingly aware of the risks which are present in daily working life. Several substances used at work are suspected of causing damage to both the egg cells in women and the sperm cells in men, and thereby the unborn child. Even diesel fumes may cause genetic damage.

## Some facts

The human body is built up of cells. Most of the cells in our bodies are continually being renewed – a process which consists of old cells dying and being replaced by new cells. The composition of each cell is fixed. It has a specific genetic structure (chromosomes and genes). Genes are the units that transmit hereditary characteristics from the parents to the child. The genes are arranged on the chromosomes and there is a fixed number in every cell. It is the cells, with their chromosomes and genes, which can be damaged if the worker – male or female – absorbs too much of a dangerous chemical into the body. The effects of this can be miscarriage – the foetus does not go the full term in the mother – or can lead to deformation or illness in the child or grandchild.

Examples of chemicals which can cause deformities in unborn children include: lead, vinyl chloride and trichloroethylene. However, it should be remembered that the dangers involved in using these substances depend on the way they are used, the amount of the substance used, and the length of time that the individual worker is exposed to them. Another factor to remember is that these substances may be combined with others.

It is important not to use petrol or turpentine when cleaning your hands at work, for example. You should use ordinary soap and water in order to avoid genetic injuries.



## E. Metals and other hazardous chemicals

Many metals and metal alloys are present at work. Some metals, such as lead, cadmium and mercury, can damage our bodies. Heated lead, as in the case of battery manufacturing or soldering, and mercury can easily concentrate in the air. Absorption by the body over a period of time may lead to various degrees of lead poisoning or mercury poisoning that also damage the nervous system.

Chromium, cobalt and nickel are examples of other dangerous metals. They are used extensively in the metal and engineering industries. These metals can cause cancer, mainly of the respiratory system.

Dangerous metal dusts or fumes are formed in welding, grinding, paint spraying, etc. Some chromium and nickel alloys can be absorbed into the blood via the lungs, and can then damage other organs in the body. They can also cause allergies.

## F. Occupational skin diseases

Various occupational skin diseases result from contact of the skin with hazardous chemicals. Occupational *contact dermatitis* (or *eczema*) account for the great majority of occupational skin diseases.

Human skin, except for the palms and soles, is quite thin. Within certain limits, it is a unique shield for protection against mechanical trauma, heat and cold, micro-organisms and chemical agents. This defence by

the skin is weakened by mechanical injury, contact with alkalis or other substances. Toxic materials can be absorbed through the skin itself; though not frequent, whole body intoxication can result from the absorption through the skin, as in the case of mercury, tetraethyl-lead and some pesticides. Eczema due to contact with chemicals is more common. In many countries, eczema accounts for nearly half of occupational diseases receiving compensation.

Occupational eczema is seen among workers in different industries; building, engineering, textile, chemical, printing workers, cleaners, painters, hairdressers, workers in plastics, rubber, electroplating, leather, electric apparatus industries, etc. In all these occupational groups, the following two types of occupational eczema are reported:

- irritant eczema (non-allergic);
- allergic contact eczema.



### ***IRRITANT ECZEMA***

Irritant eczema is a skin disease produced by prolonged contact with certain chemicals. After a time the skin dries out, becomes tender, reddens and cracks. This type of eczema is caused by solvents, corrosive (alkali) substances, detergents, coolants and cutting fluids.

Once contact with the chemical that caused the eczema has ceased, the skin can heal and become healthy again. Generally speaking, the healing process takes many months. During this period the skin is even more susceptible than usual and therefore must be protected.

### ***ALLERGIC CONTACT ECZEMA***

Allergic contact eczema is a delayed type of skin disease caused by newly acquired high sensitivity to a chemical. Very small quantities of the chemical, which previously had come into contact with the skin without causing any noticeable irritation, produce eczema due to this new sensitivity. Symptoms are irritation and swelling of the skin, with subsequent drying and flaking.

An allergy is not inherent but is acquired as a result of contact with a certain substance. Excess sensitivity – allergy – usually persists for the rest of the person’s life. The symptoms normally disappear once contact with the substance ceases.

Eczema of this type is caused by contact with substances such as chromium (present in cement, leather, rust-proofing agents, etc.), cobalt (present in detergents, colour pigments), and nickel (nickel plated objects such as keys, coins, tools). Rubber and certain types of plastics and adhesives can produce these effects.

### Points to remember!

- Contact dermatitis or eczema is one of the causes of occupational diseases. Irritant eczema is usually limited to the area of contact. Allergic eczema may not be limited to the site of initial exposure to the substance. It can take a very long time, even many years, for an allergy to develop. Knowledge of the chemicals contacting the skin is essential for preventive measures to be taken.



Allergic symptoms in the form of coughing and breathing difficulties can also occur after exposure to certain types of dust. The symptoms are colds, running eyes and nose, or asthma. The sources of this allergy include dusts of flour, cotton, hay and wood. Allergic respiratory complications can also be caused by certain artificial substances, e.g. in sprays.

## Discussion

- Is there any work involving the use of lead or other dangerous metals?
- Is there any risk of breathing in metals? How about the risk of metals entering the body through the nose or mouth?
- What are the symptoms of occupational eczema? Describe them for non allergic and allergic eczema.
- Do you know any worker who suffered from any of these symptoms? Do you know what the causes were?

## Occupational exposure limits

For most toxic substances, there is a close relationship between the amount of the substance absorbed by the body and its effects on health. By knowing this uptake-effect relationship, it is possible to evaluate the risk of exposure. This knowledge can be used to establish a safe limit of occupational exposure. This is called an exposure limit. Below the exposure limit, there should be no health hazard for the average worker and no deterioration in the degree of comfort that is required to maintain production and to keep the risk of accidents to a minimum.

The limit may, however, be expressed by different definitions. The legal status of exposure limits varies from country to country. Though the limit values are based on medical data, they are normally a compromise between different interests. Some countries establish the values as legal standards. The ILO lists nearly 1200 substances for which occupational exposure limits have been established in a score of countries.

### Points to remember!

- In practice every occupation in industry is exposed to some kind of chemical risk to health. Exposure to several kinds of risks is quite common. Sometimes different substances combine or reinforce one another.

The lower the exposure limit of a substance, the more dangerous it is usually considered to be. The limit values of some substances have been lowered based on new research results showing disorders and even cancer.

Workplace monitoring is carried out by measuring the concentration of a certain substance in the air and determining whether it exceeds the limit. Certain substances cause irritation which result in coughing, running eyes or difficulty in breathing; others cause a general feeling of sickness.



The majority of substances do not give such warning signals, and can therefore cause fatal injuries and diseases without anybody being aware of it. Measurements to ensure that the limits are not exceeded is the only way of preventing injury and illness.

When assessing the risk to health of a substance we should also remember that heavy work requires considerably more oxygen, i.e. air, than light work. This means that one potentially breathes in considerably more of the substance involved in heavy work than in light work.

## Preventive measures

### ***LABELLING***

Labelling of all dangerous substances used is very important. Persons transporting or handling them may not be aware of their nature, hazards, and the necessary precautions to be used. A label is an essential requirement to identify the contents and to warn of the hazard.

Most dangerous substances can be adequately classified as either explosive, flammable, toxic, corrosive or radioactive. Labelling should be clear and visible and kept wherever the substances are stored or used.

### ***INSTRUCTIONS FOR USE AND SAFETY INSTRUCTIONS***

Due to lack of space the information on the label on each container is often incomplete. It is, therefore, necessary to draw up more detailed information in the form of instructions for use or safety instructions.

These should contain simple and clear information on:

- the most important characteristics of the product
- risks involved in handling the product
- preventive safety measures
- suitable safety equipment
- action to be taken in the event of an accident, first aid instructions, fire or spillage precautions.

## Information

It is important that people working with chemicals receive information on the risks to health, training in how they should protect themselves and how they should wear and care for personal protective equipment. Each person working with dangerous substances should be provided with written instructions containing illustrations. Safety instruction and information brochures should be easily accessible at the workplace. This information must be shared with all individuals that may come into contact with the substance.





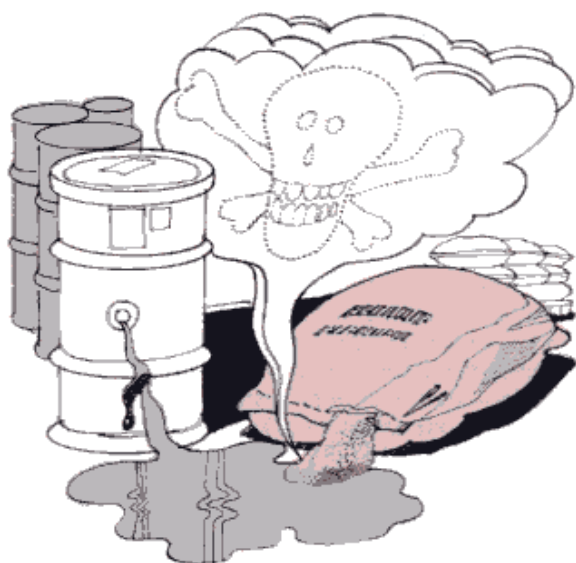

*Products incorrectly stored near each other can cause risks to health, explosion and fire.*

## The storage and transportation of chemicals and handling of chemical wastes

Every company should have written information on how chemical products should be stored and transported and how chemical wastes should be treated. If one dangerous substance comes into contact with another, e.g. in the event of a leak or a fire, dangerous gases can form. Such substances should not, therefore, be stored near each other.

## Discussion

- Are the workers given information about the risks associated with the chemicals they handle?
- Are all the dangerous substances marked so that anyone can easily know their nature and possible hazards?
- Are there clear instructions on how these materials should be stored and transported?

## Principles of technical measures

For the safe handling chemicals it is necessary to take several preventive measures. First, eliminate whenever possible very hazardous chemicals from the workplace. Secondly, limit the chances of working with hazardous chemicals. If this is not possible, prevent exposure to the substances by using suitable ventilation and personal protective equipment.

## Exchanging substances and materials

Find out if it is possible to replace a dangerous substance with a less dangerous one. In some cases it may be difficult to find replacement products. In that case, it may be useful to look at alternative production processes that can be done without using such substances.

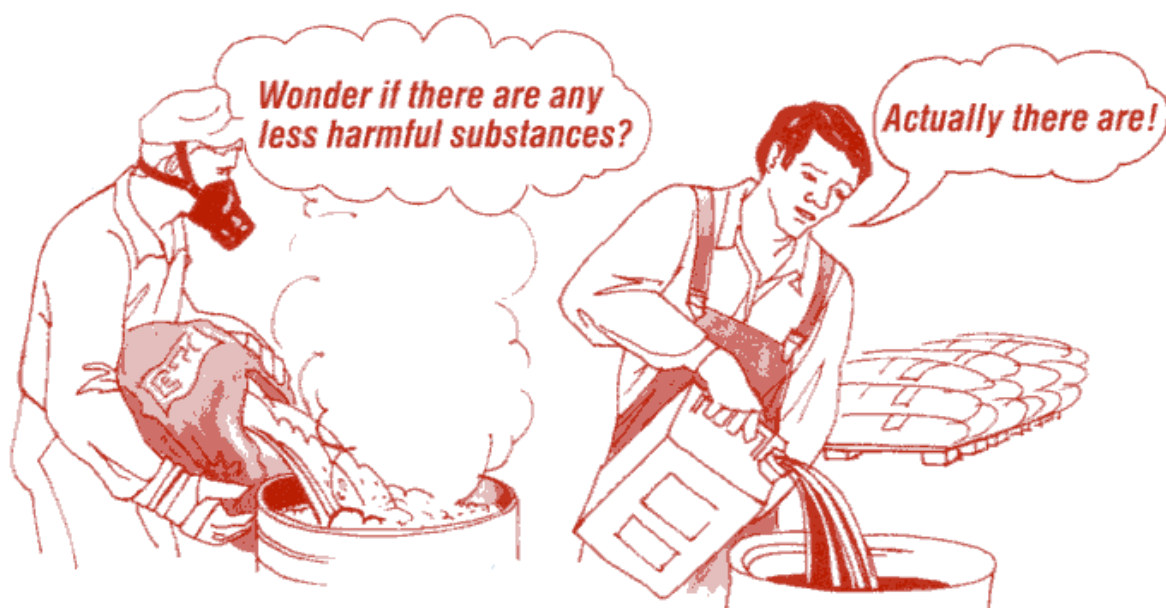

Specifications in the manufacture of products such as paints, varnishes and adhesives, are now more frequently calling for water base rather than solvent base.

Instead of using powdered substances which produce dangerous dusts, the same substances can be manufactured in pellet form.

## Improved process technology and encapsulation

Technical progress in working methods and working processes can lead to the solution of many working condition problems. One example of such progress is the change to electrostatic painting instead of spraying with paints containing solvents.

The use of industrial robots to perform dangerous work is another measure. In certain cases the entire process can be encapsulated, automated and operated from a special control room.

## Ventilation

The most effective way of reducing the risks of atmospheric pollution is to enclose the entire process. If this is not possible, then the polluted air must be extracted. Extraction and encapsulation often need to be supplemented by increased ventilation.

*An old and a new model grinder. There is a cover on the new model which protects the worker from particles and dust.*

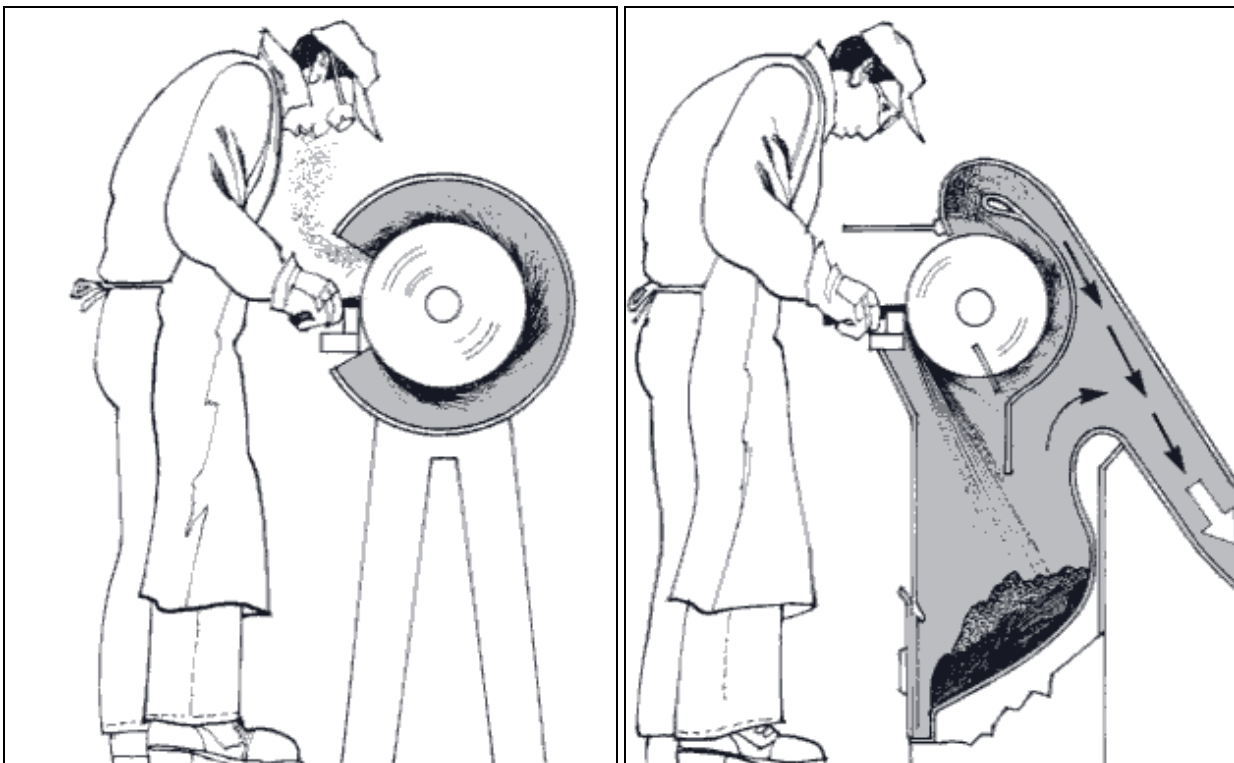

Different types of covers with built-in extractors can be connected to tools and some hand-operated machines. Both covers and booths can be used for stationary grinders and buffing machines. The problem with booths is that the wider the opening the more difficult it is to get the extractor to work effectively. The worker should therefore, also use the personal protective equipment even though a booth may be provided.

An air curtain system can be arranged for baths of dangerous liquids. The air is blown in under pressure from one side and extracted from the other, thereby screening the worker from the dangerous vapours.

A difficult problem is preventing dust and gas accumulation in welding. There are a number of smaller ventilation units now available which can either be connected to the central air extraction plant or are portable. A little hood is installed at the welding area for direct extraction of the gases.

## Maintenance

All technical equipment should be well maintained. In order for a ventilation system to work effectively, the filters should be changed regularly, the fans and ducts/pipes should be checked, gaskets/washers replaced and valves inspected.

**Points to remember!**

- Identifying chemical hazards and giving instructions is only the first step. The next step is to reduce or eliminate them altogether.

**Discussion**

- Discuss technical measures that can be taken to prevent chemical risks.
- Is there enough ventilation? Are there extractors at particularly hazardous sites?
- How is the ventilation system inspected and maintained?

**Ventilation in car plants and workshops**

In order to reduce the risks of carbon monoxide poisoning in garages and car workshops, engines should not be kept running more than is absolutely necessary to get the vehicle in and out of the workshop, or move it around inside the workshop. In other cases where the motor is kept running (during repairs, tuning adjustments or testing) the exhaust gases should be extracted away from the worker and released outside the workshop. This can be done by attaching the exhaust to a hose or pipe which leads the gases directly outside or to a suction drum connected to the air extraction system in the workshop. It goes without saying that such workshops should also have an adequate ventilation system. Since carbon monoxide replaces oxygen, a filter type respirator may not be effective if there is no way to remove the carbon monoxide gas.

When running a motor in a garage or car workshop the exhaust gases should be conducted out into the open air.

**Personal protection equipment**

**THE CORRECT CHOICE**

Using personal protective equipment can often involve discomfort. The aim must therefore be to use preventive technical measures to try and reduce the need for personal protective equipment. It is, however, impossible to reduce the atmosphere pollution produced on some jobs to a level where there is no risk to health. In such cases personal protective equipment *must* be used.

The body must be protected if there is any risk of coming into physical contact with chemicals.

Careful checks should always be made that the protective equipment meets the requirements for resistance against the chemicals being handled. This is also true of eye protection. Every worker should be informed both *by spoken* words and *in writing* on:

- when the personal protective equipment should be used
- how it should be used
- what type of equipment should be used in different situations
- with respiratory protection, what type of protection and what type of filter should be used
- how to care for the equipment.

*Three types of half mask with filter. Top: as protection against airborne particles, e.g. stone dust. Middle: as protection against gases and fumes, e.g. when using paints containing solvents. This filter contains activated carbon. Bottom: With a combination filter containing both a dust and a gas filter. These masks are examples of the simplest effective respiratory protection. Replace the filter when it gets harder to breathe or when it begins to smell. Replace the filter frequently.*

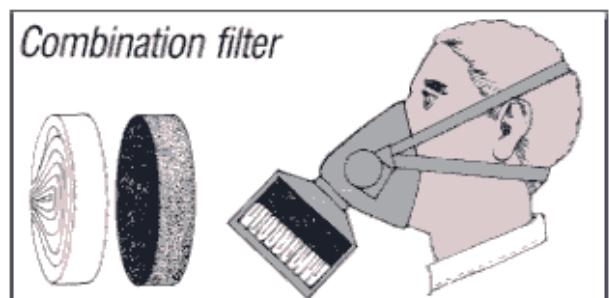
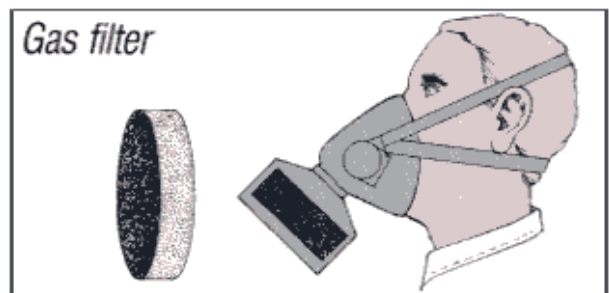
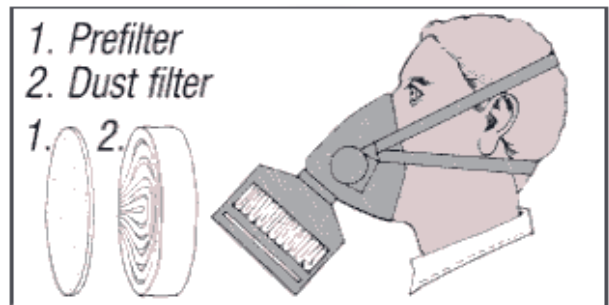

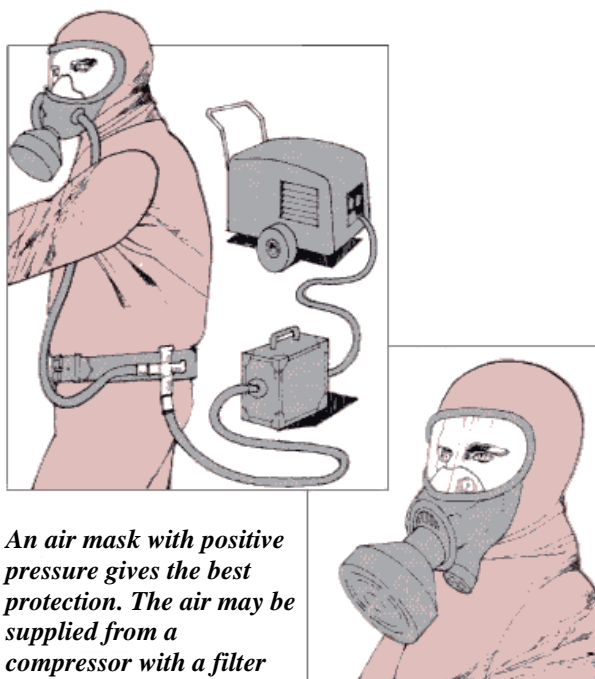

*An air mask with positive pressure gives the best protection. The air may be supplied from a compressor with a filter (shown here), a permanent compressed air plant (with filter) or oxygen bottles. In a warm climate, this is the most comfortable mask. Why?*

In situations where oxygen may be limited a filter type respirator is unsatisfactory. A unit which supplies breathing air to the worker becomes an essential part of the workers' personal protective equipment.

**Points to remember!**

- Face masks which are of the wrong type, unfit for the person, worn out or blocked by dirt, can result in serious injuries. The wearer believes that he is protected and is therefore unaware that he is exposed to risks.

*A full mask can be fitted with the same type of filters as the half mask on the previous page. A full mask will also protect your eyes and face.*

**IF YOU HAVE A BEARD, A FILTER MASK WILL OFFER YOU NO PROTECTION AT ALL BECAUSE IT WILL NOT FIT TIGHT AGAINST YOUR FACE.**



*Depending on their chemical composition, pesticides can cause serious poisoning, including nerve damage and skin and eye damage. Early symptoms may include headache, nausea, dizziness and loss of strength. Use caution when handling chemical substances. USE THE APPROPRIATE SAFETY EQUIPMENT.*

## What to do when there is an accident

Despite different technical measures, personal protective equipment and other preventive steps, accidents still happen. Quick action and proper first aid can save lives in many cases. It is therefore important that one knows what to do when a colleague is injured, and what steps should be taken until he receives proper medical care.

Unconscious people should be rapidly removed from areas containing poisonous gases. Artificial respiration should be given as quickly as possible.

Large amounts of water should be used to rinse parts of the body that have been splashed with chemicals.

## Discussion

- Is personal protective equipment against chemicals, such as masks, gloves or eye protectors, available?
- Is it the tested type?
- Is the personal protective equipment actually used?
- Who checks that people use the correct type in all the situations requiring its use?
- Who looks after the maintenance of the personal protective equipment?

*If you get a splash from a dangerous liquid in your eyes you should immediately rinse your eyes with ordinary water. The best thing to do in workplaces where chemicals are used extensively is to install an eye shower.*





# USEFUL HINTS

## Labelling, information and emergency measures

- All containers with hazardous chemicals have labels indicating the contents and warning of the hazard.
- Necessary information on safe handling and first aid measures is given on the label or as written instructions.
- Workers dealing with hazardous chemicals are trained on health risks and safe handling.
- Training includes safe storage and transportation of chemicals.
- Emergency showers and eye-wash stations are available at the worksite.

## Technical measures

- Whenever possible, less toxic chemicals are used.
- Work processes minimising the emission of gases, vapours, dusts or fumes are used.
- The source of emission of gases or vapours is completely enclosed.
- Dust-producing machines or piles of dusty materials are isolated or enclosed as much as possible.
- Work positions are chosen so that exposure to gases, vapours, dusts or fumes is minimal.
- Effective local exhaust ventilation is provided to extract gases, vapours, dusts or fumes.
- Small, portable ventilation units are used for moving jobs such as welding.
- Exposure to hazardous substances is minimised.

## Personal protective equipment

- All necessary technical improvements must be taken before resorting to the use of personal protective equipment.
- Adequate types of personal protective equipment are used:
  - helmet or head-protector
  - ear-plugs or ear-muffs
  - goggles, face shield or eye-protector
  - breathing mask
  - gloves
  - safety footwear
  - protective aprons or clothing
  - safety belt and life-line
- Personal protective equipment is suitable for the work being done.
- An adequate number of personal protective equipment is available.
- Workers are trained to use personal protective equipment correctly and whenever necessary.
- Personal protective equipment is kept complete and clean.
- Responsibility for overseeing the use and maintenance of personal protective equipment is clearly delegated.

# *FITTING WORK TO PEOPLE: ERGONOMICS*

*“Ergonomics (human engineering) is a way of thinking and planning work so that it is organised to suit the abilities and needs of the people doing it.”*

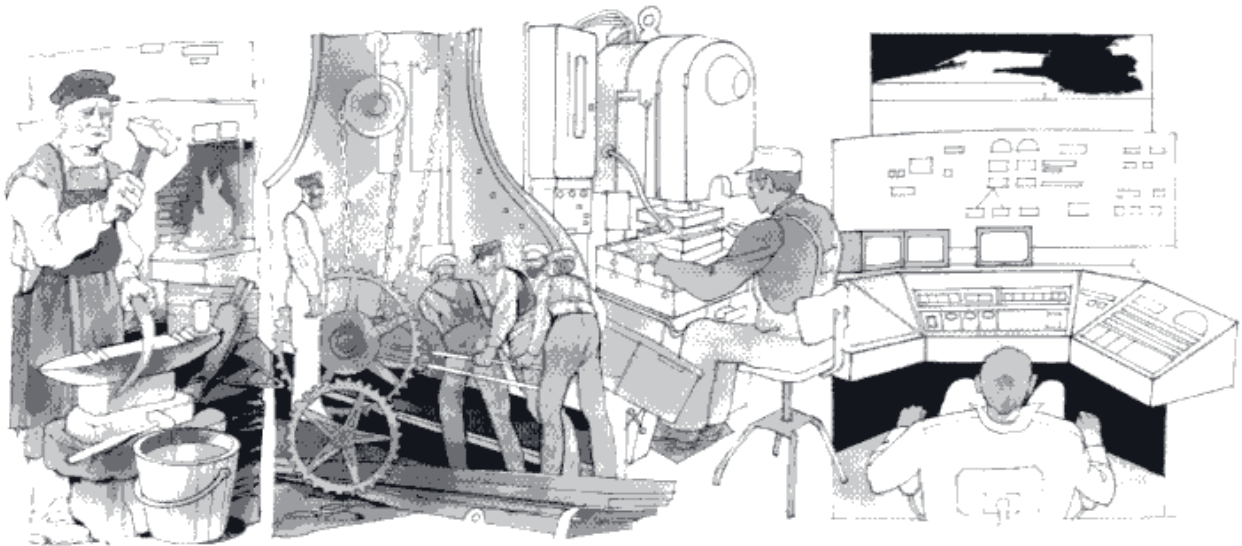

## **Changing technology and people**

An increasing amount of manual work is now being done by machines. This increase in mechanisation and automation means that the pace of work has increased and that individual work assignments have become more diversified and at times uninteresting. On the other hand, there are still many jobs that must be done manually, with heavy physical stress.

Human beings have not changed very much during the course of recorded history. While machinery and working routines are changing, people are not. This means that technology is increasingly exceeding people's ability to adapt, both physically and mentally, to change. This has various negative consequences. Technological progress has meant that manual work has been replaced by machines and computers. Heavy manual work still occurs, but many modern jobs require the repetition of simple operations or just the monitoring of a production process.

Many of our most common illnesses result from inappropriate people-work relationships. If our bone and muscle structure is overloaded this can result, for example, in back injuries or joint and muscle disorders. Many illnesses such as stomach ulcers, high blood pressure and heart disease are the result of stress at work.

### **Discussion**

- Describe machines or procedures which have changed recently because of new technology.
- Can you mention the positive and the negative effects of the new technology in your experience?

## Everybody is different

People are of different heights, they are built differently, some people are stronger than others. Their ability to withstand physical or mental stress varies. These basic facts cannot be changed. We must use these facts as a basis for planning jobs and for planning the working conditions.

Despite progress in technology there is still a lot to be done before machinery and equipment are properly designed for use by people. As a result of poor design, for example, people often suffer from lower back pain and injury to muscles and joints. Visual problems are increasing with the wide spread use of various display units and inspection work. These are among the most common health problems in working life today.

In this section, we will discuss:

- working positions – standing
- working positions – sitting
- visual conditions
- strenuous work
- controls and tools
- signals and panels.

## Working position – standing

### **HEAVY WORK OR JOBS REQUIRING A LOT OF MOVEMENT**

A job that involves standing all day puts a lot of strain on the legs. This may result in the swelling of the legs, because the muscles do not move, sufficiently to pump the correct amount of blood back to the heart. The heart has therefore an insufficient supply of blood to work with, and the individual feels tired and listless.

Jobs requiring a lot of movement and considerable stretching of powerful muscles are often performed in a standing posture – operating certain types of machinery, for example.

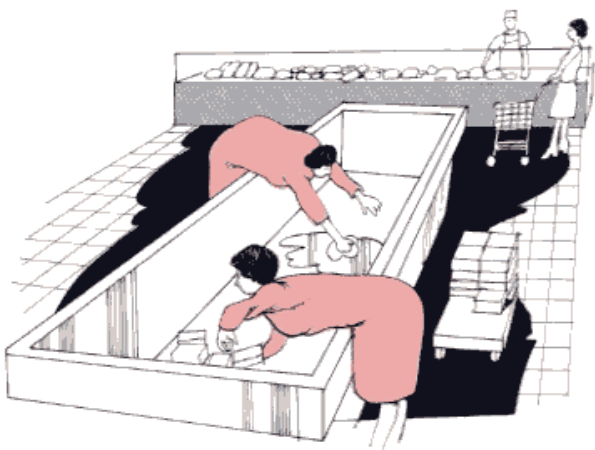

In any standing work, bending of the back should be avoided. If one leans forward or to one side, the muscles in the legs, back and shoulders must be tightened to hold the body in that position. When you keep bending, the back muscles continue to be strained. And when you straighten up again, you feel pains in the back as it has stiffened into a fixed position.

It is impossible to stand at ease all the time while working if the working height is not set correctly, or if the controls, materials and the tools to be used are not within easy reach. There should be *plenty of foot room* as it allows the working position to be altered and loads to be evenly distributed. *Avoid wearing tight fitting working clothes* as they hinder smooth physical movements required by the work.

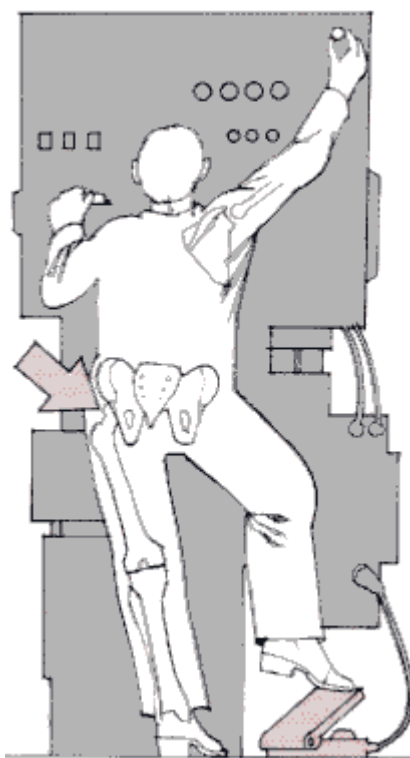

*When joints are stretched, uncomfortably pressure can cause considerable fatigue. Standing on one leg can lead to a load pressure on the hip joint which is equal to two and a half times the weight of the body. A good example of how this can occur is found in cases where the standing worker has to operate a badly positioned foot pedal.*

When joints are stretched uncomfortably pressure can cause considerable fatigue. Standing on one leg can lead to a load pressure on the hip-joint which is equal to two and a half times the weight of the body. A good example of how this can occur, is found in cases where the standing worker has to operate a badly positioned foot pedal.

## Working height

The working height is important. If it is incorrect, the body gets tired quickly. The working height should be such that the job can be done without the back bent and with the shoulders relaxed and in their natural position.

The work should be done at a natural hand position as close to the body as possible. Comfortable working height varies depending on what type of work you are doing. If the work demands precision, where vision is important, then the working height should be higher. Precision work often also requires support for the arms. Where heavy work is involved, the working height should, for certain operations, be low enough to allow the worker to use the weight of his own body to the best advantage. It is important when working in a standing position that:

- the things you need for the job are within easy reach
- the height of the work table is adjusted to the height of the worker, so that the working surface is level with the elbows when standing with the back straight and the shoulders relaxed
- the worker should stand straight in front of and close up to the work table/bench with his weight evenly distributed on both feet. There should be enough room for his legs and feet
- the special nature of the work can mean that the working height must be changed
- controls, such as levers or switches, should be lower than shoulder height
- the surface that the worker is standing on should be suitable for the working conditions
- proper footwear reduces strain on the back and legs.

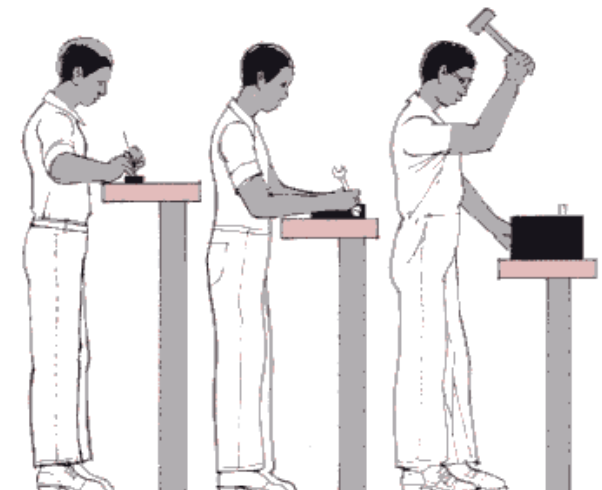

*Different types of work require different working heights. The working surface should be considerably higher for precision work than for heavy work.*

## The proper footwear

It is very important to have the correct footwear for jobs involving a lot of standing and walking. Shoes should be stable and fit well – if not, the feet will not be given the support they need. The result will be a tired back and legs. If the work involves anything which might damage the foot when dropped, such as heavy metal components, safety shoes or boots with reinforced toe-caps should be worn.

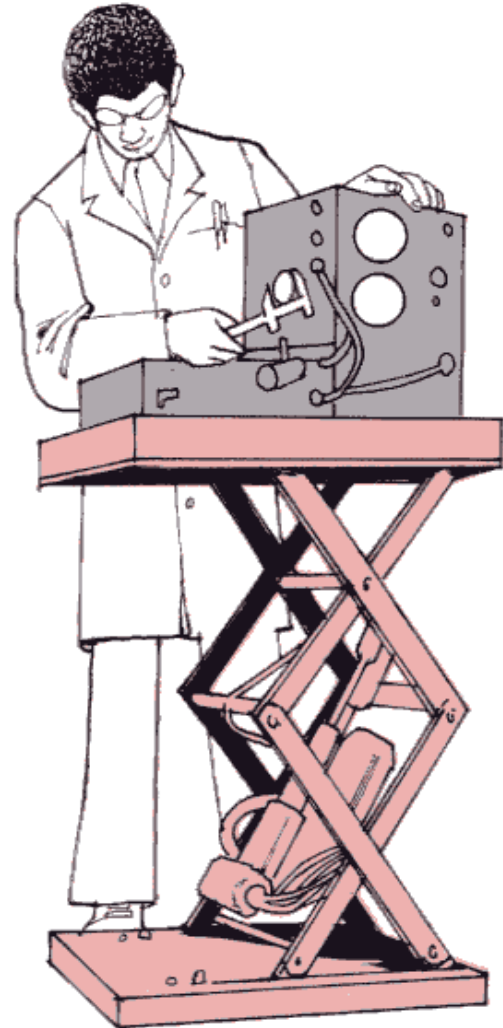

*The work height can be varied according to personal requirements with the help of an adjustable work table.*

### Points to remember!

- If possible the worker should be able to alternate from a sitting position to a standing position and vice versa. Work requiring no change in the working position should be alternated with work requiring more movement.

## Discussion

- Give examples of jobs where the posture seems awkward.
- Can the working height be changed for workers who have to bend frequently?
- Examine carefully the surface that the worker is standing on. Could this be improved?
- Examine carefully the footwear in use. Does this provide proper support and protect the toes?

## Working position – sitting

### LIGHT WORK

Work which does not require a lot of muscular power and which can be performed within a limited area should be done in a sitting position. It should be possible to reach the entire work area without unnecessary stretching or twisting.

A good sitting position means that the person is sitting straight in front of and close to the work. The work table and chair should be designed so that the working surface is just about the same level as the elbows with the back straight and the shoulders relaxed.

For precision work, if possible, some form of support for the elbows, forearms or hands should be provided. The support should be adjustable.

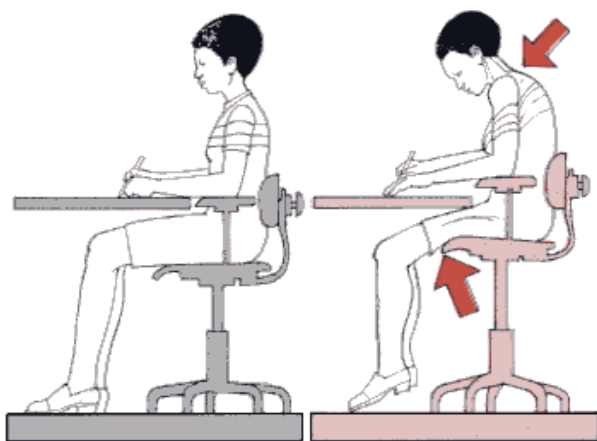

*The working position should be as comfortable as possible.*

### Points to remember!

- Sitting all day is not good for the body. There should therefore be some variation in the jobs performed. A good chair allows easy changes in the way work is done and in the leg positions.

## The work chair

The design of the chair should satisfy certain basic requirements. The chair chosen should be suitable for the job being done and the height of the work table. It should be possible to adjust the height of the chair. Sufficient “leg room” is necessary to allow free change of leg positions. The chair height is most comfortable when the feet are placed flat on the floor. When this is not possible, a foot rest can sometimes help to add to seating comfort. But it should be sufficiently large to allow the feet to be placed on it in several different positions.

## Discussion

- List the conditions which make up a good sitting posture.
- What are the symptoms which people will complain about if they have to keep a bad sitting posture?
- Are there chairs or make-shift sitting arrangements which need improvement?

## Visual conditions

You have to be able to see clearly what you are working with. Most objects should be 50 cm away from the eyes, providing that they are not too small. If the objects are very small they should be placed on a raised surface or it may even be necessary to use some form of magnifying glass. Otherwise you will have to lean forward with your head bent downwards and that puts an unnecessary strain on the neck.

Operation of sophisticated equipment such as microscopes or computer display units while sitting puts enormous demands on the worker.

Concentrating on small objects through a microscope or watching a monitor screen for a long period of time puts a considerable strain on the eye muscles. It can even result in blurred vision, though after resting, normal vision returns. This form of static load on the muscles of the eyes causes headache and eye strain.

A further complication in this type of work is the repetitive finger movement and the restricted posture. The results are pains in the hands and arms; muscle stiffness; and pains in the back and shoulders. Display units of computer terminals must also be designed carefully. In addition to visual and postural conditions, the display unit operators should be given frequent breaks to avoid excessive fatigue.

An uncomfortable sitting position. The ocular angle of the microscope should be adjustable. The work chair should also be adjustable and have support for the back.



Discomfort arising from work with sitting operations of machines or display units can be reduced in the following ways:

- careful adjustment of the display or lens conditions to suit individual vision
- the eye-to-display distance and the display positions should be adjusted to the worker
- adjustment of the general lighting in the workplace to the quality of illumination required or the provision of special lighting in the work areas
- varying the work as much as possible, so that rest for longer periods of time from work which puts a strain on the eyes is possible

- ensuring that individuals have the right to take a break in a separate room in order to rest their eyes
- ensuring that the work chair is adjusted to a suitable height and that the sitting position is comfortable.

Another cause of uncomfortable working positions is protruding machine parts. Sometimes parts of machinery or other equipment are located so that the worker has to twist his body in order to “look around the corner”. Such equipment and machinery is all too common.

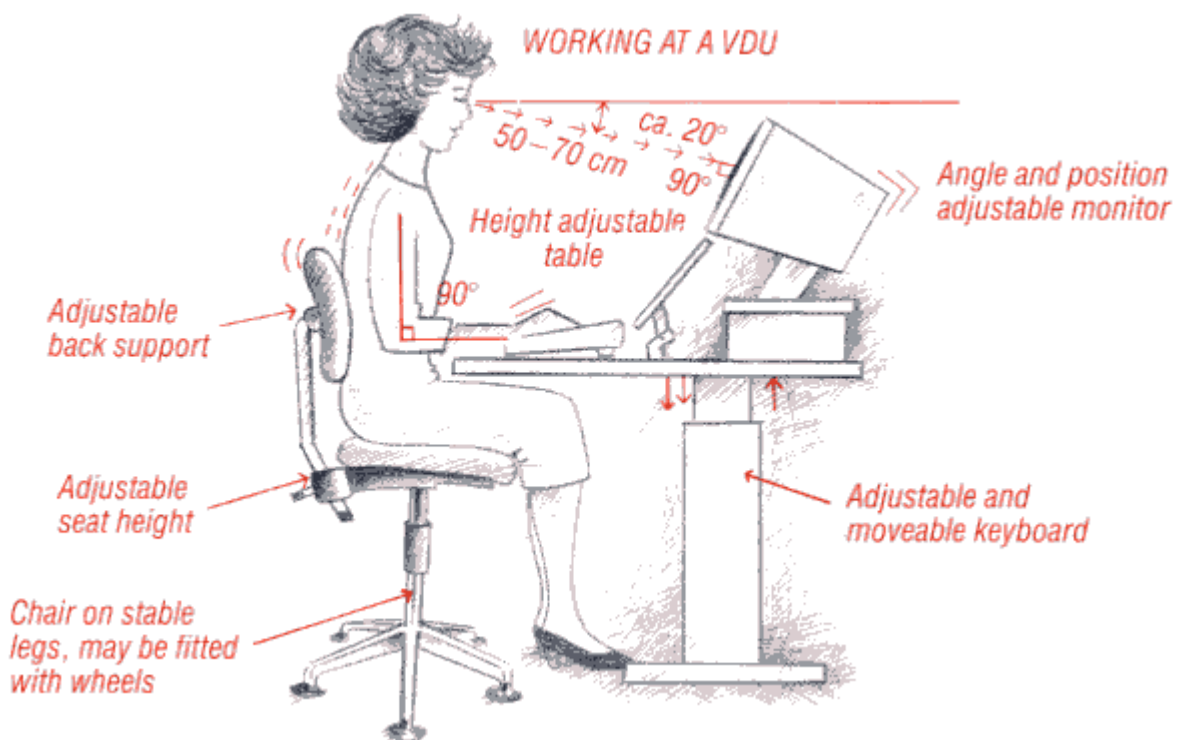

**EACH USER MUST BE ABLE TO FIND HIS/HER BEST WORK POSITION**

## Strenuous work

### HEAVY PHYSICAL WORK

Continuous heavy manual work increases the rate of breathing and the heart beat. If the worker is not in good physical shape, he will tire easily.

There are risks involved in working at maximum capacity. The use of mechanical power to replace heavy work helps reduce these risks. Mechanical power also helps increase the work opportunities for people with less muscle power.

On the other hand, it is not a good idea to give people jobs that require no physical effort. Such jobs are tiring and boring.

It is important that the workload is not too heavy and changes during the day. Effective rest periods must be included in the day's work.

### STATIC LOADS

The most natural way to work is to work rhythmically. This “dynamic” load enables the muscles to alternate between contraction and relaxation. If an object is lifted up and held in this position, this puts the muscles under a uniform “static” load. Muscles under static load become tired because they are continually contracted. After a short time the muscles feel painful. A static load on the muscles over a long period of time will also increase pressure on the heart. The pulse increases because the blood remains in the muscles.



*Too high hand positions or forward bending are among the most common ways of creating “static” load.*

### Points to remember!

- Static loads, such as high hand positions or bending, are common. They are often combined with repetitive operations visual loads and work pressure. It is necessary to have a new look at the way work is done.

### Discussion

- Is there any physically heavy work at your workplace? What suggestions can you make to improve the work?
- What are the special problems of sitting operators of microscopes, visual display units or similar equipment?
- Explain what is meant by the static load. Give some examples from your own experience.
- Are there any jobs involving static loads in your workplace? Can you think of ways of reducing them?

### Lifting

Lifting is a problem which has to be dealt with carefully.

Lifting and carrying heavy loads manually should be avoided. This should be performed by mechanical devices as much as possible. Otherwise, several people should help. It is important that everybody work together and use the correct lifting methods.

### The correct way to lift

It is the legs and not the back that should be used to lift loads. Throw your shoulders backwards, arch your back and bend at the knees. Keep the load as close to your chest as possible and then straighten your legs to lift the load while keeping your back straight:

- load close to your body (starting position)
- feet apart and body correctly balanced
- bend at the knees
- neck and back in an almost straight line
- straighten the legs while keeping the back straight
- where possible the load should be held in both hands.

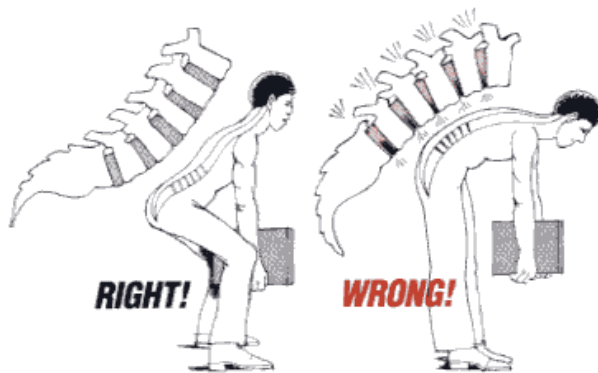

## Discussion

- What sort of heavy lifting jobs do you have?
- Do you know anybody who has a bad back resulting from lifting loads that were too heavy or from lifting things incorrectly?
- Do you have any lifting equipment to help you? Is it used properly? If not, what is the reason?
- Do you need more or other types of lifting equipment? If so, what types and for what sorts of operation do you need them?

## Design of controls and tools

### CONTROLS

It is important that control switches, levers knobs of different kinds are within easy reach of the operator in a normal standing or sitting posture. Frequently many of the controls of a lathe or similar machines are below waist height and at more than arm's reach from the operator position. The location is of the primary importance for frequently used controls.

### FURTHER REQUIREMENTS OF CONTROLS INCLUDE:

- selection of adequate types of controls – (e.g. hand controls for precision of high-speed operation and foot controls such as pedals for larger force operation, though two or more pedals should not be used per operator)
- distinction between emergency controls and those which are used in normal operations (by separation, colour coding, clear labelling or guarding)
- prevention of accidental activation of controls (by proper spacing, adequate resistance, recesses or shields)
- adequate resistance in operation, with a clear indication of activation of the controls

- operating procedures are easy to understand according to common sense (knobs on electrical equipment to turn clockwise for “on” and “increase”, but valves turn counter-clockwise for “open”, etc.)

Operating procedures based on common sense are very important. In a hurried situation or an emergency, people tend to operate important controls as they would normally react. Common sense reactions may differ among countries. Sometimes, “on” and “off” switch positions can even be reversed. It is important to ensure that operation directions are compatible with common sense and do not entail any danger by mistaken operations. If a piece of equipment is purchased that violates the local custom for movement, it should be very clearly labelled to indicate “on” and “off” actions.

## Hand tool selection

The design of hand tools can affect the productivity and health of an operator if it does not fit the individual or task. In most instances the tools are bought from an outside vendor. Poor quality ones must be avoided.

The following considerations are important in selecting hand tools:

- avoid static load at the shoulder or arm due to continuous holding of a tool at a raised position or gripping of a heavy tool (proper arm position and adequate weight)
- avoid awkward wrist angles (while using tin snips, pliers, etc. )
- reduce uncomfortable pressure on the palm or joints (too small pliers)
- avoid pinch points (as by double-handed tools such as tin snips, scissors)
- make handles easy to grasp, with good electrical insulation and without sharp edges or corners
- consider special-purpose tools for repeated actions, e.g. a soldering iron with a bent tip, a tool holder in using a chisel, etc.

### Points to remember!

- Easy and dynamic handling is important for controls and tools. They are usually small and may seem unimportant. But the selection of good controls and tools are as important as that of costly machines. Ask opinions of the operators who use them.

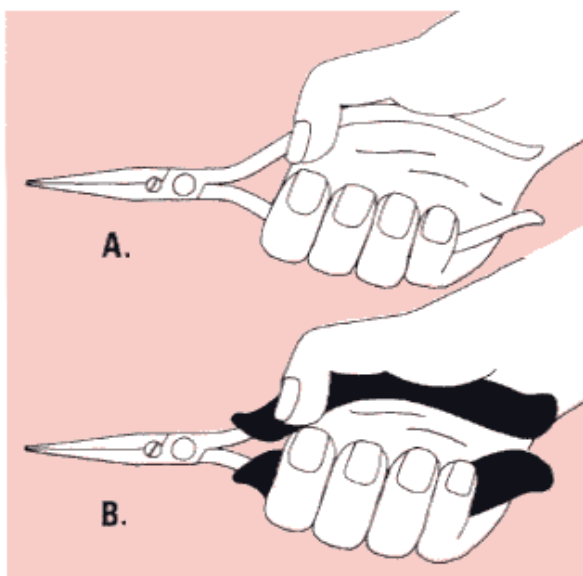

*With a short pair of wire clippers (A) force applied to the base of thumb may produce soreness. With a palm-adapted pair of pliers (B) the operator can make four times more motions before getting tired.*

## Signal displays and panels

### **OBSERVATION REQUIREMENTS**

It is easy to react to one clear signal. It takes a fraction of a second to press a button when a signal lamp lights and mistakes rarely occur.

However, as soon as one has to make a choice before acting, things become more difficult, (if you have to press a button when a red lamp flashes from among several lamps of different colours).

Consequently all information and signal systems used to initiate subsequent operations should be as simple as possible.

In order to be able to read instruments rapidly it is important that:

- the instrument panels are sufficiently large and clear
- the instruments are clearly marked and placed according to work process or category
- all gauges turn in the same direction
- all gauges are easy to read instantly when pointing at the normal functioning position (e.g. by marking of target zones)

*There are optimal directions-of-motion to avoid confusion.*

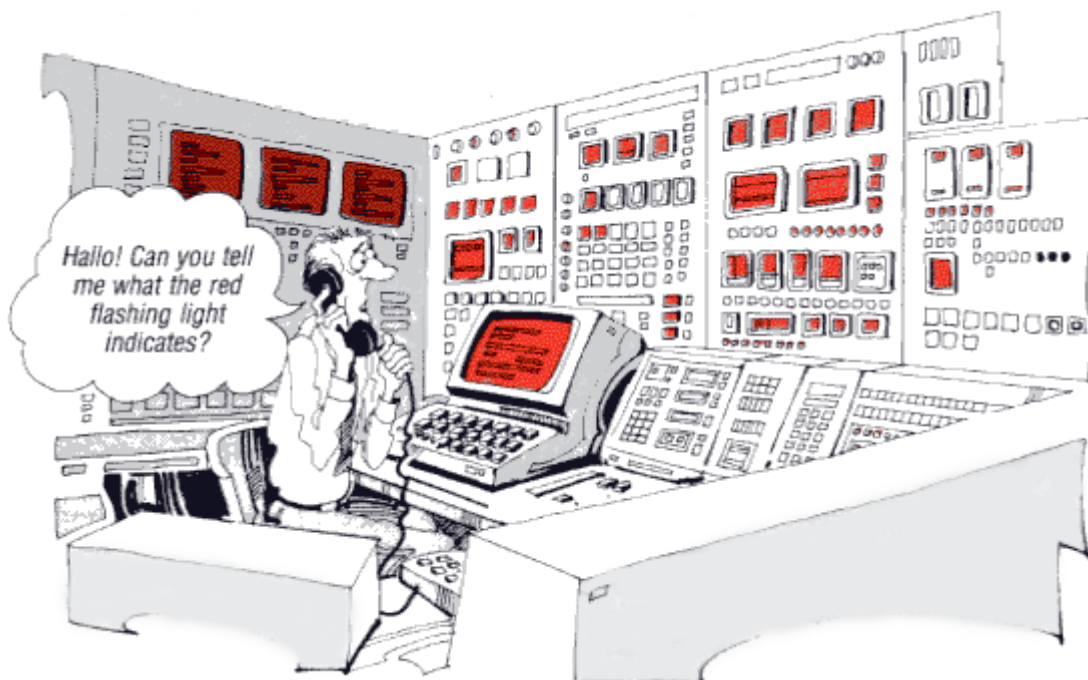

*There are many instrument panels in working life today where different types of signals, lights and gauges enable different features of the production process, i.e. speeds/rates, pressures, levels, supply and discharge of gases and liquids, to be read rapidly. They should be arranged on a panel so that one look at the panel can show whether any of the gauges is giving an abnormal reading.*

## Location of signals and displays

All signals and information displayed to the operator must be easily distinguishable. This can be done by the proper placement of display positions and by changing the size, shape or colours of the displays. Good ways to do this include:

- placing the instruments or indicators in logical sequence or in correspondence with the machines represented by them
- locating frequently used ones between the work table height and eye level
- changing the size, shape or colour for different categories of instruments or indicators
- using simple words or adequate abbreviations for clearly marking each instrument or indicator
- removing or covering unused displays
- making emergency signs outstanding by the position, size and colour
- using signal lights of different colours where appropriate.

### Points to remember!

- In transferring information in daily work, brief and clear instructions are best. The same is true for the instrument-to-person transfer of information. It must be easy to read and easy to understand what action is needed.

### Discussion

- Are there any operators who have to deal with too many controls?
- Are hand tools properly designed? Mention examples of tools at your workplace for which the selection of proper types is important.
- Which jobs involve monitoring instruments or instrument panels?
- Are the instruments, buttons and controls so placed that they are easy to manipulate and distinguish from each other?
- Is there any risk of operating controls or reading gauges incorrectly?

# USEFUL HINTS

## Standing positions

- Work that involves the bending of the back is avoided as much as possible.
- Work is arranged to alternate standing and sitting.
- Working height allows work with the back naturally straight and the shoulders relaxed.
- Working height can be higher for precision work and lower for heavy work.
- Work is done with a natural hand position as close to the body as possible.
- Instruments needed for work are within easy reach.
- Enough room is available for the legs and feet.
- Switches or other points of manipulation should be lower than shoulder height.
- Foot plates can help smaller workers.

## Sitting positions

- Variations in work to avoid sitting all the time.
- Table or hand position height is at the level of the elbow.
- Seats are padded and the height is individually adjustable.
- Seat height gives little pressure on the lower side of the thigh, and allows placing the feet firmly on the floor.
- Backrest with padding gives comfortable support to the back.
- Footrest is used when seat height is unchangeable.
- Enough leg room is secured for easy change of leg positions.
- Materials and tools are placed within easy reach.
- Continued repetitive movements of the fingers are avoided.



## Visual conditions

- ❑ Objects should be able to be clearly seen from the normal work position.
- ❑ Objects can be seen without constantly bending the head.
- ❑ Variations in work prevents high visual load for a long period.
- ❑ Frequent breaks are taken to avoid fatigue caused by strenuous monitoring.
- ❑ Illumination is adjusted to make visual conditions easier, including local lighting.

## Lifting

- ❑ Lifting or carrying of heavy loads is mechanised as much as possible.
- ❑ When moving heavy objects, the height difference is minimal.
- ❑ Static holding of materials or tools is minimised.
- ❑ When lifting, the feet are apart and the knees are bent.
- ❑ Weight is lifted by straightening the bent knees without bending the back.
- ❑ When lifting is combined with pushing, one foot is placed ahead in the direction of movement.
- ❑ Twisting of the body while lifting is avoided as far as possible.

## Panels and controls

- ❑ Most important displays (signals gauges, etc.) are placed within easy sight.
- ❑ Information presented by displays is simple and easy to read.
- ❑ Panels, consoles, worktables, etc. are sufficiently large and all their parts are easily seen from the normal work position.
- ❑ Instruments, displays and controls clearly marked to show what they are for.
- ❑ Differences in size, colour, shape and location are used to make different instruments, displays and controls distinguishable.
- ❑ All gauges are easy to read whether they are in the normal functioning position or not.
- ❑ Emergency controls are easy to find and operate.
- ❑ Accidental activation of controls is prevented by proper spacing, resistance, shield, etc.
- ❑ Direction of operating controls is easy to understand according to the local custom.

## Tools

- ❑ Hand tools are not too heavy for easy handling.
- ❑ The shape of each hand tool is so made as to prevent awkward hand positions.
- ❑ Hand tools can be gripped without undue pressure on tissues and joints.
- ❑ Double-handed tools have stoppers to avoid any pinch points.
- ❑ Tool handles are easy to grasp and adequately insulated.
- ❑ Special-purpose tools, made for easy handling, are specifically constructed and used for the most frequent actions.



***Servicing power tools is very important and repairs should be carried out by properly skilled tradesmen.***

# WORK ORGANISATION AND WORKING TIME

*“Our experience of work is dependent to a large extent on the number of hours worked, the pace of working and the pattern of work assignment. More and more attention is now focussed on the work itself and how work is scheduled.”*

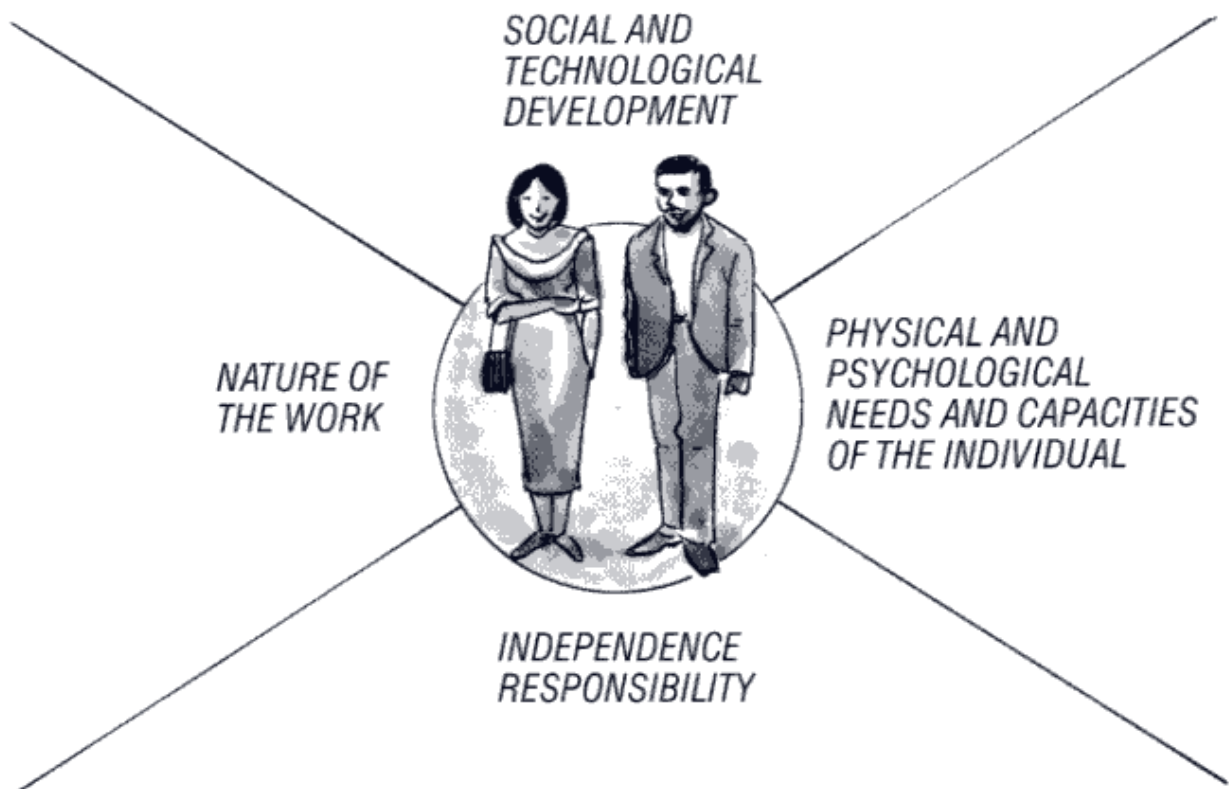

A satisfactory working environment is both an environment free from accident risks and physical and mental stress, and an environment that has been adapted to the needs and limitations of man.

It should also allow employees to participate actively in designing their own workplaces and duties. In this manner, the ground is prepared for personal involvement, personal development and pleasure in one's work.

## Better quality of working life

In our daily working life, the way work is done and scheduled is fundamental. When a worker's skills and abilities do not match the job, or when schedules of work do not leave sufficient time for rest and leisure, serious problems arise for both the worker and the employing organisation.

In the family and among friends and acquaintances, it is vitally important to feel that our work is meaningful, that we can exercise some influence, and that we really have the opportunity to develop our own individual abilities and to provide a service to society. The pattern of work organisation, which has a direct influence on job content, largely determine whether work is arduous or enhancing, unpleasant or satisfying.

The duration of work – every day, every month, every year and for the whole of our working life – can also greatly affect the safety, health and value of our daily life.

In this section, we will discuss:

- work organisation and job content
- ways to improve work organisation
- hours of work
- time for rest and leisure
- shift work
- new patterns in working time.

## Work organisation and job content

### CHANGE IN JOB TASKS

Technological change in modern society has also changed the way individual jobs are performed. Organisation of work, including use of skills, control over work and communications, has been greatly affected by a high degree of “division of labour”.

Until recently, it was assumed that job characteristics were predetermined by technical and economic considerations. Managers were supposed to find the “one best way” to define jobs. The idea was to break the work up into task and assign each worker the simplest possible combination of tasks.

It was often thought that in order to make sure any worker could do the work, it was necessary to design tasks that call for minimum skills. However, if our jobs do not provide the possibility for developing useful skills and self-respect, we can all too often lose our sense of self-esteem. Such jobs are not very productive, either.

We now know that better jobs can be provided by improved methods of work organisation. These methods

are important not only because they improve jobs from the workers' point of view, but because they lead to higher productivity and better use of technology.

## Poorly organised work

Before considering how jobs can be improved, we should consider some of the disadvantages of work which is poorly organised. For example:

- oversimplified jobs require little skill and provide few opportunities to learn anything useful. The worker is “underutilised”;
- repetitive jobs are monotonous and boring;
- jobs which have no possibilities for co-operation are isolated;
- jobs which do not allow for learning or growth limit the workers' career possibilities;
- jobs which have no real responsibilities require continuous supervision;
- jobs where performance is measured by repetition of a simple task are frustrating and stressful.

Obviously, workers whose skills are poorly utilised and who are over supervised, tired, bored and frustrated are unlikely to care very much about production. They are more likely to make mistakes, to have accidents, to be absent and, if they get the chance, to leave.

The *psycho-social* conditions can “poison” us in a dangerous way. Poor management can create a bad atmosphere and do much to undermine the feeling of job satisfaction. Changes are needed if we are to create a working situation that guarantees job satisfaction and a feeling of wellbeing at work.

### Points to remember!

- Poor work organisation is bad for the worker and for the enterprise. Workers must have a chance to develop and use skills if they are to contribute fully to production goals. Treating workers like machines ignores their potential and creates a dissatisfied, unproductive work atmosphere.

The planning of these job assignments should be based on a clear understanding of the aspects of work.

## A good job

To improve work organisation and job content, it is useful to consider the characteristics of *good jobs* free from excessive stress, fatigue or pressure. The right tools equipment, supplies and assistance and enough time to do good work will be necessary. In addition, a good job should have:

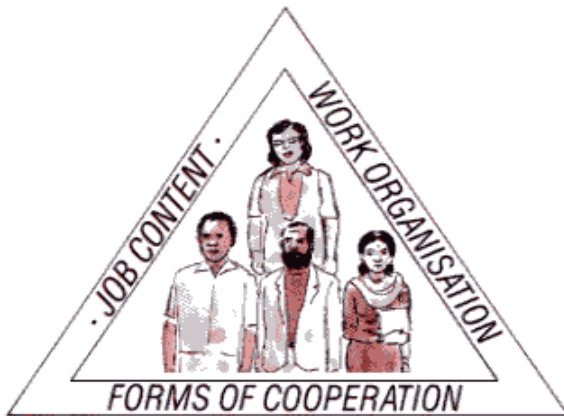

*An emphasis on physical environmental factors must be supplemented by a knowledge of the social and psychological climate at the workplace and its influence on the individual's sense of well-being, his health and the quality of his life.*

*Job content, work organization and the forms of cooperation are particularly important factors in terms of job satisfaction.*

- variety and a reasonable work cycle;
- some choices to make about the work with knowledge about and responsibility for results;
- opportunities for communication and support among fellow workers;
- enough skill for self-respect and the respect of others;
- arrangements for continuous in-service training;
- a chance of a better job in the future.

These conditions will make a job more challenging. In most cases, they require changes in shop-floor organisation, communication and layout and job

*Examples of typical buffer stock techniques in manufacturing operations.*

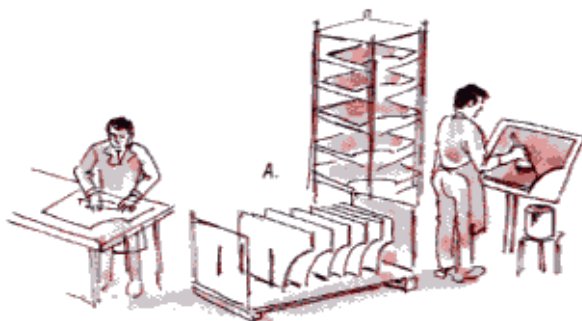

**A. High-stacking machine used as a buffer**

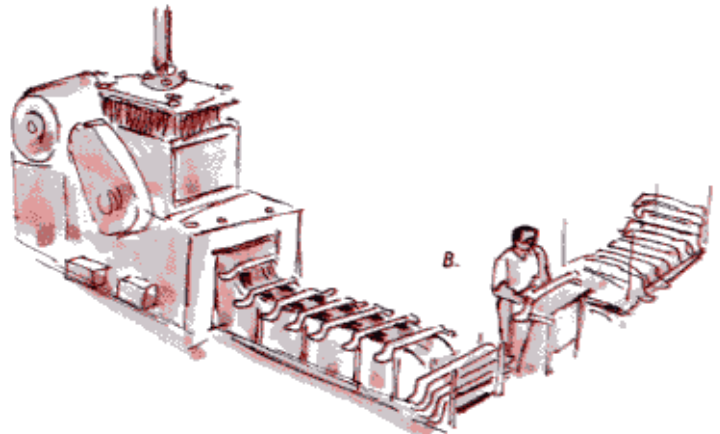

**B. Buffering track**

relations. There is always the danger of increasing the work intensity excessively.

This can result in increased occupational stress. But experience shows that machine-paced, boring jobs are more stressful than mentally challenging jobs, and that strictly controlled operators show greater symptoms of stress than operators with expanded autonomy.

This does not mean that a good job is the same for all workers. Workers have different backgrounds, skills and preferences. Their personal strength or weaknesses and attitudes towards work are also different. For example, one worker may emphasise pay, another companionship, and yet another responsibility and high skills. Therefore, jobs should be arranged so as to meet individual needs and preferences.

### Points to remember!

- We all need to feel that our work has some value and that we can build on and develop our innate abilities.

## Ways to improve work organisation

### RE-ARRANGING INDIVIDUAL JOB CONTENT

The following ways are often used to improve work organisation and job content:

- mechanisation* (but be careful; mechanisation can easily lead to machine-paced tasks and poorer jobs);
- ergonomic* improvements, especially with respect to appropriate equipment and sequence of work;

- *change of layout* of worksites (e.g. using a round table) so as to allow easier communications and co-operation;
- *job enlargement* by combining separate tasks, for example by creating shorter parallel lines, each with a longer cycle time;
- *buffer stocks* of unfinished products; the worker can draw on upstream stocks when wanting to work faster, and another downstream stock can act as a buffer when the worker takes a break or is working at a slower pace;
- *job enrichment*, by adding more responsible tasks such as inspection of semifinished products or machines, maintenance and repair.

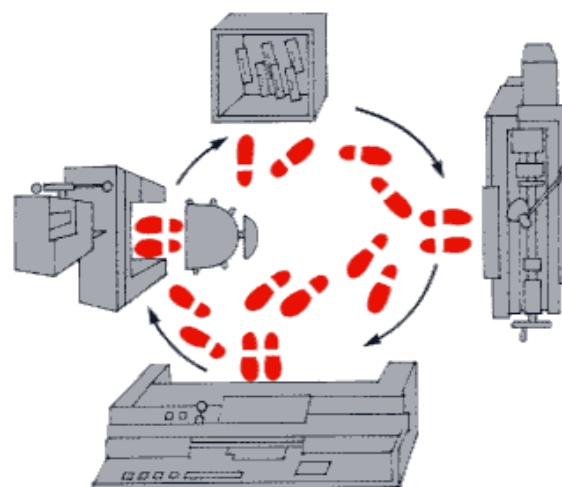

*A workstation organized so that one worker performs a sequence of operations.*

*Layout of a group organized to perform an industrial process in a sequence of operations.*

*Shop for turning, drilling, grinding and assembly.*

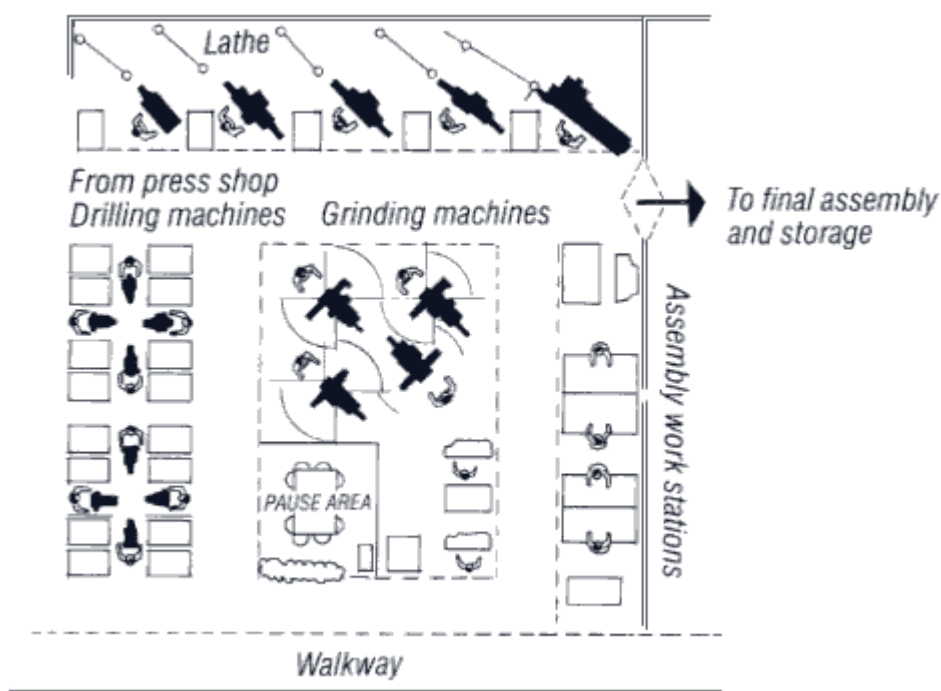

## Group work

A very flexible way of improving work organisation and job content, with many advantages for both management and workers, is *group work*. Most people like to work together and co-operate. Moreover, in co-operative work, the weaknesses of one worker can be compensated by the strengths of another. Similar

adjustments can be done for differing preferences, temporary problems including absences, etc.

There are various ways of organising effective group work. Many of the traditional types of work take into account the advantages of group work. A typical new form of work is a semi-autonomous work group which can decide, to a considerable extent, work methods, scheduling, work assignment and problem solving.



Another new form is to have group work of workers whose skills overlap with those of some others.

To facilitate the improvements in work organisation, early planning with the participation of all parties is essential. These improvements are directed not only at improving working conditions but also more efficient work. They make the work operation more flexible and adaptive to production procedures and change-overs. For workers, improvements such as reduction in occupational stress, greater opportunities for co-operation, better use of skills and improved career prospect are combined with the benefits of a more productive enterprise. Many modern management techniques, such as quality circles or management by objective, make use of participative planning.



*A company or an organization usually has an activity planning function, which describes how different groups and departments are supposed to work and interact in relation to the overall goals. Responsibilities and powers are divided and fines of communication and forms of cooperation are defined.*

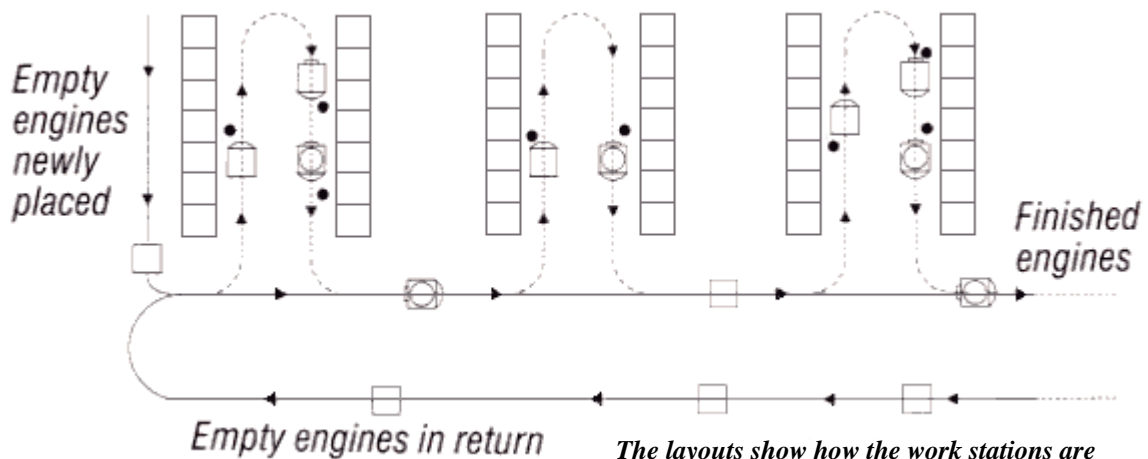

*The layouts show how the work stations are organized and are therefore useful in planning the working environment.*

**Points to remember!**

- Good work organisation provides room for individual and group initiative. Suggestions should come from both supervisors and workers. As there are no simple solutions to the problems of work organisation, we must take advantage of these suggestions and the experience of others.

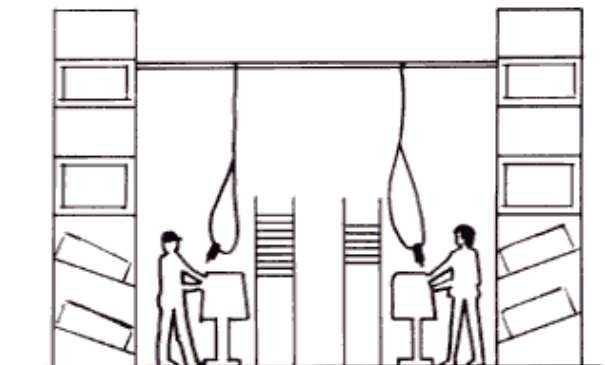

*Each assembly group can decide how the work should be divided in the group. There is no forced mechanical steering of the assembly process.*

## Discussion

- Are there any examples of high pressure jobs?
- How about jobs requiring repetitive and boring movements?
- Are there any jobs in your workplace which you think combine appropriate responsibilities and are done in a good working atmosphere?
- Discuss other types of work in your workplace which can cause mental stress and give rise to problems.
- What are your suggestions for improving the organisation of work in these problem-raising jobs?
- What methods will be suitable to get suggestions from your supervisors and workmates?

## TIME SPENT AT WORK

The number of hours of work and the way those hours are organised can significantly affect the day-to-day life of the worker. It is essential the workers have free time for rest and leisure.

The number of hours worked is one of the principal demands of a job. Limitation or reduction of hours of work has been the subject of numerous ILO Conventions and Recommendations. The arrangement of working time, including shift and night work, allowance for seasonal changes, family duties, training, and commuting problems, is also important.

The basic hours of work are usually fixed by law. These hours of work may be further limited by agreements between employers and workers. The actual hours worked often differ from this normal duration, since overtime can be added. If the hours of work are too long or their arrangement is inappropriate, they can influence health and safety, the degree of strain and fatigue and the quality of working life in general.

## Hours of work

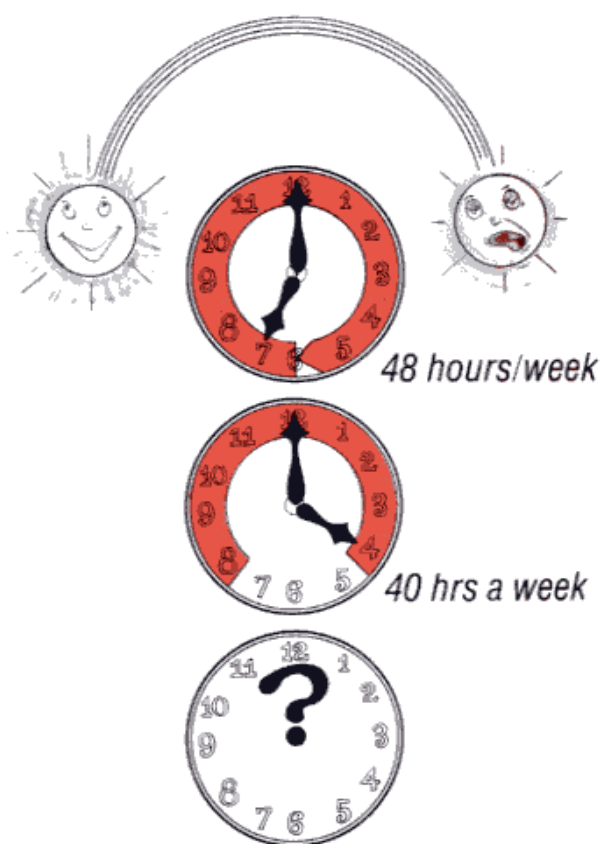

*The international trend points towards shorter working hours.*

## NORMAL HOURS OF WORK

Normal hours can be fixed in terms of the day or of the week. Time worked beyond normal hours constitutes overtime or exceptions. Usually the limits to the number of normal hours in both a day and a week are set by law or regulation. The traditional legal limits are eight hours per day and 48 hours per week. Many countries now prescribe lower limits. The ILO Recommendation No. 116 of 1962 reaffirms the 48-hour work week as a basic standard and calls for *progressive reduction* towards the social objective of a 40-hour work week. This progressive reduction of normal hours generally focuses on the number of hours per week.

As for the *length of the working day*, normal hours of eight or less are well established in most countries. In special circumstances, such as shift work, hotels and transport, or in flexible working hours, the working day on particular days can exceed the limit of eight hours. The introduction of a five-day work week may sometimes make it unavoidable to work more than eight hours on at least some of the working days. The question is raised whether a working day substantially longer than the eight-hour standard is acceptable. This question must be answered by examining how work schedules are adapted to individual needs without imposing adverse consequences.

## OVERTIME WORK

Overtime means hours worked in excess of the normal hours. If the normal weekly hours are not exceeded, hours worked on a certain day in excess of the normal daily limit are, in some cases, also regarded as overtime. When overtime is frequent and substantial, the resulting long actual hours of work may affect health, safety and well-being.

Overtime usually means not only longer hours but also higher rates of pay. For the enterprise, overtime work may be needed for organisation of some preparatory, seasonal or emergency work or for economic reasons. Problems arise when overtime becomes the rule rather than the exception, which involves substantial additions to wages. These higher earnings are advantageous to individual workers; however, increased earnings from long hours of overtime are at the expense of rest, family life and leisure. Frequent overtime work has other disadvantages, including unstable earnings and adverse health and safety effects. Thus there may be a need to reduce or limit overtime.

### EXCESSIVE HOURS OF WORK

Excessively long hours of work can be caused by:

- seasonal concentration of work;
- intermittent work being spread over long work days, as in road transport;
- labour shortages, especially of skilled or specialised workers;
- weak or difficult enforcement control.

Whether hours of work are “excessive” or not is in fact a relative question, but usually long hours of work do have effects on workers including:

- excessive strain and fatigue, both physical and mental;
- poor quality of work and increases in errors;
- increased numbers of accidents;
- insufficient sleep, in some cases associated with difficulty in sleeping and possible use of drugs;
- decreased resistance to illness, often leading to early ageing;
- disturbances in family life or social activities.

These negative effects of long hours may be compounded by extreme climate, poor hygienic or safety conditions, malnutrition, poor general health, poor housing conditions, lack of public social services, long commuting distances and over-burdened transport facilities.

#### Points to remember!

- There has been a progressive decline in normal hours of work, but actual hours of work often remain a major problem. Excessive working hours cause real problems: serious fatigue, accidents, ill-health, and a deterioration in the quality of life.

## Discussion

- Do you sometimes feel exhausted at the end of a long day’s work?
- Should overtime work be continued as you do it now?
- What do your family members say about the time you spend on leisure and family affairs?
- Compared with five or ten years ago, are there any significant changes in working time? How do you evaluate them?
- What future changes do you think will be desirable in hours of work?

## Time for rest and leisure

### REST PERIODS AND BREAKS DURING THE WEEK

Provision of a sufficient number of rest periods and breaks is essential for workers’ safety, health and well-being. Such rest periods and breaks include:

- short breaks during working hours
- longer breaks for meals
- daily or nightly rest
- weekly rest

*Short breaks* during working hours are necessary to prevent fatigue. They are particularly important in jobs requiring fast machine-paced work or continued vigilance.

*Meal breaks* should always be provided. They are often regulated by law. A meal break of 30 minutes or more is usually indispensable in a working day of eight hours.

When the meal break is less than one hour, the worker may find it difficult to leave the workplace to take his meal. This creates a need for meal-serving facilities.

Workers are inconvenienced by a working day composed of two or more periods separated by long breaks, for example 7-9 a.m., 11 a.m.-2 p.m. and 7-9 p.m..

*Daily or nightly rest* needs to be long enough to secure sufficient sleep and suitable leisure and family life activities. The limitation of daily hours of work provides a minimum period of rest. In the case of irregular working time or shift work, precautions are particularly necessary to secure daily or nightly rest.

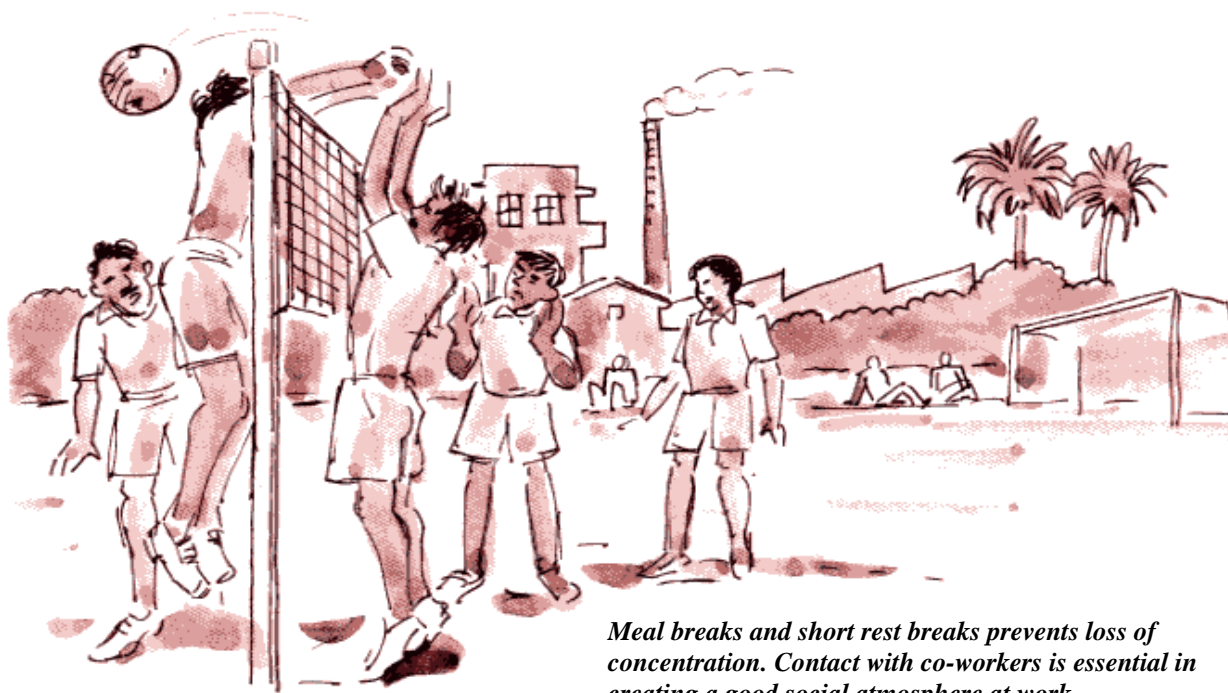

*Meal breaks and short rest breaks prevents loss of concentration. Contact with co-workers is essential in creating a good social atmosphere at work.*

*Weekly rest* is fundamental to the health and well-being of workers. The minimum amount of weekly rest established in the ILO Weekly Rest (Industry) Convention (No. 14) and the Weekly Rest (Commerce and Offices) Convention (No. 106) is 24 consecutive hours in any seven-day period. The widespread adoption of the five-day week has made two weekly rest days common in a number of countries.

Particular problems of weekly rest are:

- the weekly rest day does not always coincide with the customary rest day;
- working seven days a week is still commonly seen in poorly regulated sectors.

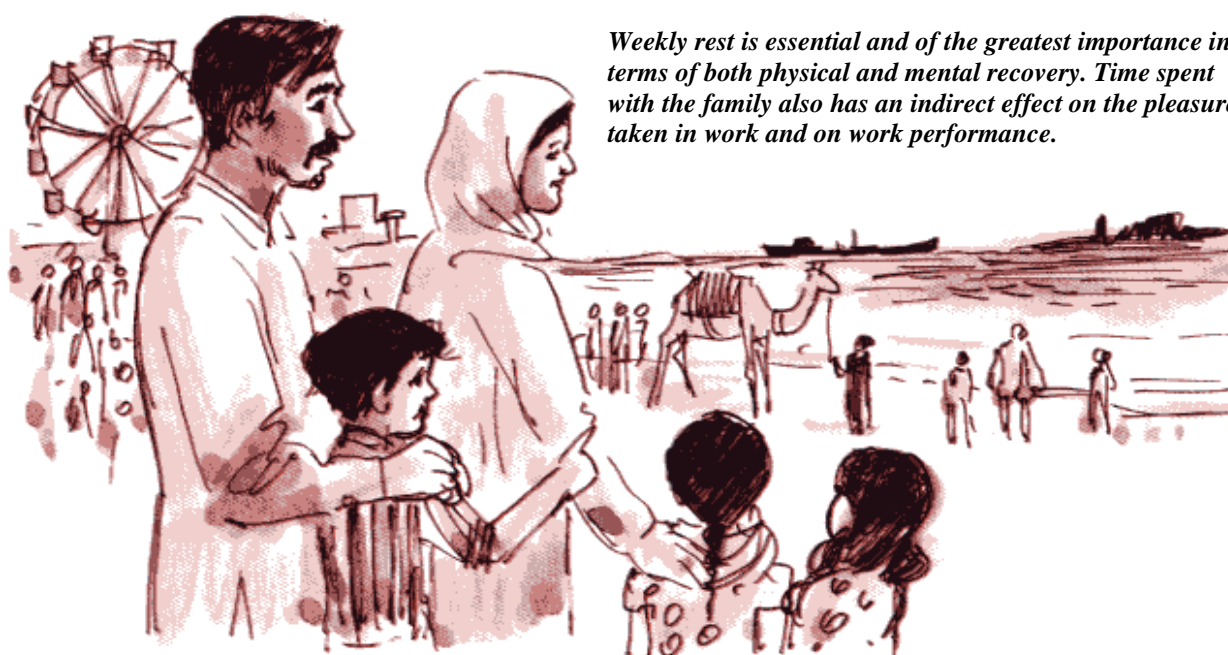

*Weekly rest is essential and of the greatest importance in terms of both physical and mental recovery. Time spent with the family also has an indirect effect on the pleasure taken in work and on work performance.*



## Holidays and leave

In most countries, entitlement to annual holidays with pay is provided by law. The minimum length of paid holidays laid down by national laws differs among countries. The ILO's Holidays with Pay Convention (No. 132) prescribes holidays of at least three working weeks for one year of service. It is a common practice to grant longer holidays to workers with long service or those working under particularly stressful or hazardous conditions.

In addition, all countries observe certain days as public holidays which usually have some religious, historical or cultural significance.

It is important to make the terms of holiday entitlement precise, and to ensure that the holidays are actually taken. Pay in lieu of holidays does not have the same effect as actual time off.

Other forms of leave are often related to the culture and way of life in each country. They include casual leave, compassionate leave, educational leave, etc. Periods of absence due to illness or injury should not in principle be counted as part of annual holidays, though applications of this principle may differ between countries. In many countries, sick leave is covered by the social security system, but there are some countries where sick leave may also be granted by the employer. Educational leave taken after some years of service to acquire knowledge and skills is also becoming important.

## Shift work



## SHIFT SYSTEMS

Irregular working hours are becoming more common in many industries, which inevitably creates problems such as effects on health and social life. Very few people can adapt completely to shift work and irregular working hours due to disturbances in their "biological clock" and in daily life.

There are various reasons for adopting shift work. First, shift work is needed where continuous production cannot be interrupted for technical reasons. Second, shift work is adopted in railways, fire stations, hospitals and other public services. Third, shift work is also introduced for economic reasons to make more use of costly equipment. In any form of shift work, workers grouped in separate crews work in turn to cover the whole operation time.

The effects of shift work are primarily dependent on shift systems. The effects are more significant when the system involves night work or does not allow a weekend break. The main types of shift systems are:

- the *discontinuous shift system*: The undertaking operates less than 24 hours a day with a daily interval and usually a weekend break (e.g. morning and afternoon shifts);
- the *semi-continuous shift system*: the undertaking operates 24 hours a day but with a weekend break;
- the *continuous shift system*: the undertaking operates 24 hours a day and seven days a week.

The crews can be assigned to shifts either:

- by *fixed (or permanent)* shifts in which each crew is permanently assigned to the same shift; or
- by *rotating* shifts.

In the case of rotating shifts, the frequency of rotation from one shift to another is important. Crews may change shifts every week or at shorter or longer intervals. Numerous variations are possible, especially for continuous shift systems. There are also irregular shift assignments as in the case of train drivers or broadcasting stations.

## Problems of shift work

Working on different shifts causes a disturbance in normal biological rhythms. The body temperature varies during the day, for example, and normally has its minimum in the early morning hours and reaches a maximum in the evening. This coincides with other changes in blood, tissues, hormonal and brain activities which are suited to the day-work and night-sleep pattern. These rhythms cannot be reversed completely by transfer to night shifts. It is known that complete adaptation does not take place even after continuing the day sleep and night-work pattern for weeks. This is one reason why night work is arduous and why day sleep is



shorter and less recuperative than the normal night sleep.



*Shift workers may suffer from disturbed sleep patterns, stomach complaints etc. Shift work must be arranged and adapted to prevent the shift worker from becoming socially isolated. Work should also be planned with regard to the employees' chances of using public transport to and from their work.*

### **THE DISADVANTAGES OF SHIFT WORK ARE OF TWO TYPES:**

- *effects on the workers' health:* the disturbance of normal biological rhythms brings about special problems. These include digestive disorders, fatigue, and sleep disturbances. Chronic ill health can result in the form of stomach and intestinal disorders. Lack of sleep can, moreover, lead to various nervous complaints;
- *effects on family and social life:* shift workers often have difficulty with family activities and maintaining normal contact with their spouse, parents and children. Social relationships are also disturbed. This includes contact with friends, participation in clubs, associations and trade union activities and public entertainment.

## **Practical measures to improve the conditions of shift work**

To improve the conditions of shift workers, action in two areas is needed:

### **IMPROVING SHIFT SCHEDULES:**

- shorter hours of work (including reduction in weekly hours of work, granting of additional holidays and limiting the proportion of working life spent in shift work): a reduction in working time helps relieve burdens inherent in shift work;
- arrangements to allow workers to choose their work shift in the case of fixed shifts;
- improvements in the frequency and pattern of shift rotation: rapid rotation with more crews is generally favoured as it reduces the need for adjustment and the frequency of night shifts;
- sufficient rest periods between shifts;
- sufficient rest days, especially weekends;
- changes in shift rotation time, if necessary.

### **IMPROVING CONDITIONS OF WORK AND LIFE:**

- fixing meal breaks and other breaks during a shift;
- providing canteens or other facilities for hot meals and drinks;
- providing transport services;
- ensuring first-aid services and medical supervision;
- providing places to rest and relax during breaks and providing recreational equipment;
- improving housing conditions;
- improving access to training and social activities.

Since the difficulties of shift workers are increased with night work, systematic efforts are particularly necessary to reduce the burdens of such workers.

### **Points to remember!**

- When the regular "morning-work", lunch, "afternoon-work" pattern is not allowed, the worker is seriously affected. Extra wages cannot compensate for lack of sleep and other adverse effects. Measures are necessary to improve not only shift schedules but also conditions of work in a broad sense.



Conditions on and off the job, during working hours and leisure time are intimately linked and affect our well-being. There is an interaction between man and his total environment, which affects our ability to cope with stress.

**Social life, leisure activities, smoking habits, rest and relaxation – all of these factors may affect our position on the health-sickness spectrum.**

## Discussion

- Do you think that the breaks and weekly rest you have are sufficient for your recovery from fatigue?
- Compare your present work schedules with those of five or ten years ago. Are the changes agreeable to you?
- What arrangements in work schedules would be helpful for you to improve your family and social life (starting time, breaks, reduced overtime, weekly rest)?
- If you work a shift system, what services or facilities are needed to help you cope with the problems involved?

## New patterns in working time

In accordance with recent technological and social changes, some new patterns of working time are spreading, taking into account individual needs. These may differ from country to country. Examples are flexible hours, part time work, staggered hours and so on:

- *flexible hours*: within certain limits, workers fix their own work schedules from day to day (usually all workers must be present during “core” periods);
- *part-time work*: certain workers work fewer hours than others;
- *staggered hours*: different firms or units adopt different starting and finishing times.

These patterns permit flexibility in working life, but they may also lead to problems with timekeeping, overtime, friction between groups of workers, inconvenience of trade union or other group activities, etc. Caution is necessary when these new patterns are introduced. They should be introduced only after full consultation of the workers and their organisations.

## Discussion

- What are the minimum and maximum number of annual holidays with pay in your workplace? Do you and your workmates make good use of them?
- Do you have problems with the scheduling of your own annual leave?
- Are there any steps necessary to make better use of leave entitled to you?
- Do you think that new patterns in working time have any impact in your workplace?

# USEFUL HINTS

## Work organisation and job content

- Strenuous or arduous work is mechanised with due consideration about new job content.
- Work standards allow many opportunities to take short pauses without falling behind in the work schedule.
- Buffer stocks are available to avoid machine-paced work.
- Tasks are combined so that work is varied and the cycle time is long enough.
- Simple and repetitive tasks are often alternated with other types of tasks.
- Rotation is used if particularly tiring or boring tasks are inevitable.
- Communication with other workers is possible while working.
- Work in isolation is avoided.
- Workers have certain choices about the way work is done.
- Group work is organised so that there is room for individual and group initiative in carrying out the tasks.

## Working time and rest periods

- Daily hours of work leave enough time for rest and leisure.
- Actual hours worked per week are within a reasonable limit.
- A sufficient break is provided for meals.
- Short breaks are scheduled.
- Weekly rest and public holidays are adequate.
- Annual holidays with pay are provided and are taken.
- Other forms of leave are available so as to meet the individual needs of the workers.
- Flexibility in working time is considered appropriate.

## Shift work

- A limit on actual working hours is considered in arranging a shift system.
- There is a rapid rotation of shifts takes place rapidly where possible.
- Limits are set on the number of consecutive night shifts allowed.
- Short intervals between shifts are avoided.
- Shift-changing time is arranged taking into account local custom and the available means of transport.
- First aid services and ambulance facilities are available during all shift periods.
- Canteen services or facilities for meals and beverages are provided for all shifts.
- Means of transport, such as bus services, are available for all shifts.
- Appropriate rest places for shiftworkers are provided.
- Shiftworkers' access to training and social activities is supported.

# DAILY ACTIVITY FOR SAFETY, HEALTH AND WELL-BEING

*“Take care of yourself and your workmates.  
Do not get old before you need to! Make  
sure your workplace comes up to standard  
and is consistent with your well-being.”*

*A good working environment is everyone’s concern. It can only result from collaboration between employers and employees. In designing new, or modifying old workplaces and production systems, psychological factors and people’s reactions have to be taken into consideration.*

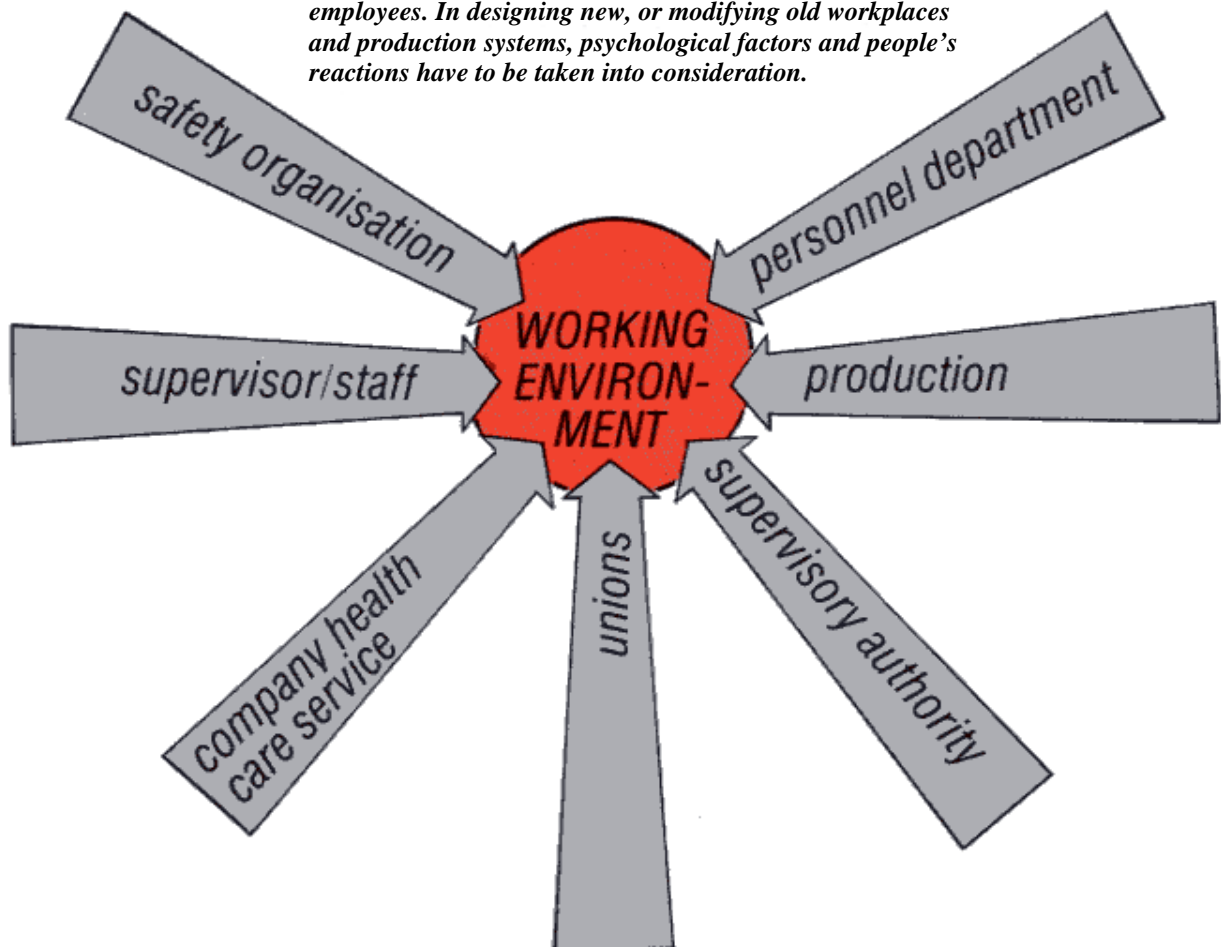

## Better safety, health and working conditions improve productivity

The improvement of safety, health and working conditions and environment is gaining attention today in numerous countries. To realise the improvement, a programme of action is required on concrete measures for introducing changes. Active participation of management and workers is essential to finding practical solutions.

Improvement in occupational safety and health and work organisation enhances productivity by lessening the number of interruptions in the manufacturing process, by reducing absence, by decreasing the number of accidents and by improving work efficiency. It is to the benefit of the workers because they then run less risk of injury or illness. It also contributes to job security and well-being.

In this section we will be discussing the various objectives of safety, health and welfare activities at work and how they can be organised in practice.

This section contains:

- objectives for safety, health and well-being at work
- inspection routines for checking workplace conditions
- enterprise health service
- good safety and hygiene practice
- welfare facilities
- information
- safety committees
- national and international laws and regulations
- action programme for better safety, health and working conditions.

## Objectives for safety, health and well-being at work

The principal objectives of safety, health and well-being at work are to:

- identify* the risks which can lead to injury, illness and unsatisfactory conditions at the workplace
- analyse* and determine the nature of the risks and problems; how they affect the worker and what measures need to be taken
- correct* the situation and introduce improvements
- follow up*, ensuring that the measures have been properly carried out and have had the intended effect
- ensure* that no new problems have been introduced into the workplace.

Safety is of a preventive nature; the aim is to stop the creation of risks and unsatisfactory conditions and their incorporation into better working conditions. This requires contributions from, and, above all, co-operation between both workers and management.

## Discussion

- Who is responsible for the health, safety and welfare of workers?
- Do you receive regular visits from government inspectors?
- Do the workers have confidence that management will provide reasonable protection?

## Routines for workplace inspections

### SYSTEMATIC EXAMINATION

Risks of injury and ergonomic and organisational problems can be found by systematically examining and inspecting the workplace. Safety inspections are one of the most important preventive measures that can be taken to ensure a safe workplace. The nature of the work will determine how often the safety inspections should be conducted. If there is a high risk of injury, inspection must be conducted at frequent intervals.



***It is a good idea to carry out a safety inspection once every three months, when the responsible supervisor, production manager, safety representative, trade union representative and perhaps the full safety committee take part.***

***In addition to checking that measures have been taken in accordance with previous decisions, one should also look for risks that may occur when new chemicals, machines or equipment are introduced.***



If a safety committee or a similar committee has been established, it can take the initiative in these workplace inspections. If a safety committee does not exist, one can be organised with the full co-operation of the workers and management.

When carrying out workplace inspections, it is important first to establish:

- the emphasis and scope of the inspections
- how they are to be carried out and what form the reports should take
- which persons should be included in the inspection committee (in addition to the safety officers or representatives)
- who is responsible for seeing that the improvements suggested are presented to the management and implemented
- what checks should be done as a follow-up to ensure that the agreed steps have been taken.

Workplace inspections will vary slightly between large and small enterprises. It may be difficult to carry out a single comprehensive inspection of a large enterprise because production may be split into many different sections or departments. In smaller enterprises the entire production is usually located in a smaller area.

## Implementation

Workplace inspections can be classified according to the composition of the inspection committee. The purpose of the inspections are:

- *General workplace inspections* are principally intended to check the general standard of the workplace conditions within an entire enterprise or factory and are carried out at least once a year.
- *Detailed workplace inspections* are carried out within specific areas. They can be carried out regularly, e.g. once a month.

While inspecting individual items against a checklist, the employees at each workplace should be asked whether they have any problems or suggestions regarding safety, health and working conditions.

One can either inspect the entire workplace at once (according to the list on the next page) or investigate specific problem areas, such as the risks of accidents, ergonomic conditions, noise, etc.

Therefore, the third type of workplace inspection is:

- *Special workplace inspections.* These inspections follow no particular schedule and can cover one or more specific problems, e.g. studying the risks involved in handling chemicals or improvements in lifting. Special safety inspections can also be made

of one specific workplace or a process posing special problems.



**Inspection and regular checks make equipment safer.**



**Special inspectors often need to carry out annual inspections of transport vehicles, cranes, pressurized vessels etc. The supervisor responsible and the operator should also carry out their own inspections of the equipment. To improve safety, daily inspections should be carried out by the operator when starting up the machines.**

It is impossible to remember everything that has to be checked during each workplace inspection. Therefore, a checklist is helpful. Each inspection team member should carry and use such a list during the inspection.

At the end of this text there is an example of checklist which can be used as an aid in the different kinds of workplace inspections. You can add the items which are better suited to your particular workplace.

## Areas for workplace inspections

While carrying out a workplace inspection the inspection members should check the following:

- inspection records
- overtime log
- workshop premises and passageways (cleanliness, exits free from obstacles, etc.)
- fire-fighting equipment
- waste disposal
- electrical equipment
- welding equipment
- lifting equipment
- ropes, chains and accessories
- scaffolding
- compressed air lines
- climate and ventilation
- lighting
- noise
- dust, fumes, gases
- fuel/oil and paint stores
- paints and solvents in use
- explosives and other chemicals
- personal protective equipment
- ergonomic problems
- individual work areas
- trucks and transport vehicles
- work organisation problems
- welfare facilities
- safety education
- health care
- first aid.

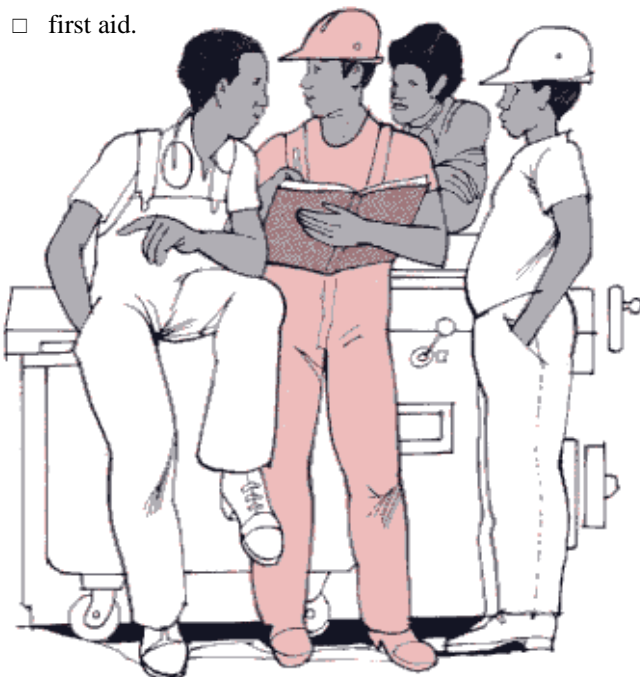

## Workplace inspection record

It is important that the observations made during workplace inspections are noted, so that any shortcomings or suggestions can be reported. Concrete proposals should be made based on the record. The workplace inspection record is a useful aid in planning and carrying out improvements. It can be compared to a log book in which items and corrective measures are continually entered. The records should not consist simply of completed checklists, but include proposals for improvements.

In making proposals, try to obtain experts' advice. Engineers, safety officials, veteran foremen or experts outside the enterprise may be helpful to you.

It is *important* to know *who is responsible for the workplace inspection records* and where they are kept.

*Suggested measures should be formulated in away that can be accepted by the staff involved. Issue information on the results of safety inspection rounds and proposed measures. It may be necessary for purchase officers, maintenance staff, training officers etc., to be aware of the measures that have been introduced in order to make them as effective, practical and economical as possible.*



## Discussion

- Are workplace inspections carried out?
- Who do you think should participate in the inspection rounds:
  - for general workplace inspections?
  - for detailed workplace inspections?
- Would it be a good idea for checklists to be used regularly in your workplace?
- Are there some records on previous workplace checks? Are they known to the management and workers?
- What do you think would be routine steps to plan and carry out inspection regularly?
- Do you think management would encourage you to do this and report problems to them

## Health services

### TASKS OF ENTERPRISE HEALTH SERVICES

In many countries, enterprise health services usually deal with both technical and medical preventive measures, hospital care and rehabilitation. They are

*An occupational health centre for one or more companies with a total workforce of 2-3000, can employ a physician, 2-3 nurses, a safety and hygiene engineer and some secretarial staff. It is also advisable to include an occupational therapist and social worker on the staff.*

expert services which should be designed to fit the organisation and production system.

The primary task of the health service is to cooperate with management, workers, and the safety committee in establishing a preventive health service and improving safety, health and working conditions. To this can be added the task of rehabilitation. Providing sick workers with medical care is secondary to these functions.

Some of the *principal tasks of enterprise health services* are:

- *description*, evaluation and information on the conditions at the workplace which can cause physical or mental illness among the workers
- *participating* in the improvement of the safety, health and working conditions and giving advice when management and workers are involved in planning new or renovating old work premises, production processes and work methods
- *helping* management, engineers and workers with advice and information on the application of preventive measures
- *organising* quick and reasonable rehabilitation in case of illness and reduced ability to work.



In order to provide an efficient service, it is vital that effective health services are established in all larger workplaces. Medium-sized and small enterprises can request service from the outside or from joint health services. Physicians and nurses attached to such services and the safety engineer/inspector should have impartial advisory roles as experts.

The enterprise-based health service should cooperate with public authorities and other agents such as the health authorities, hospitals, safety organisations and rehabilitation units.

## Health checks and investigations

Health checks are an important method of carrying out effective preventive health services. The planning of health checks must take into account the existing conditions of work. The health service conducting the health checks must take into account the possible exposure of workers to various working condition factors such as noise, climate, radiation and chemicals as well as possible ergonomic and mental health problems. The service should assist management, safety officers and the safety committee in workplace inspections and in evaluation of the workplace conditions. They should also provide technical help for monitoring physical and chemical hazards at workplaces.

The ergonomic factors, working time and psychosocial factors should be investigated in order to take steps to fit the work to workers and their demands. Examples of such factors are work postures, job stress, shift work and so on.

*The report on health checks and investigations should be completed with proposals for improvements.*

The health units conducting the health checks should be responsible for organising first aid measures in case of accidents and sudden illness. The health unit should act as an adviser in purchasing equipment, reorganising workplaces, as well as in personnel planning.

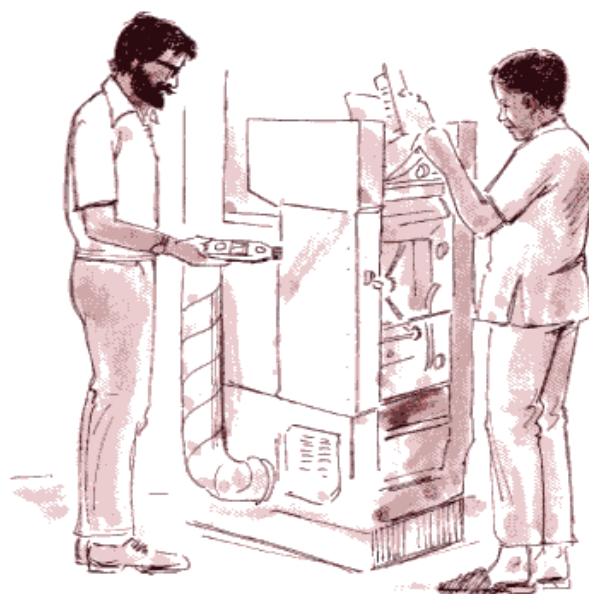

*The work of the company health centre includes carrying out medical examinations of new employees, regular health checks for certain risk groups e.g. workers exposed to lead, noise, radiation etc. An important task is to take part in planning new premises, buying equipment and chemicals etc.*

## Discussion

- Is there a doctor or a nurse providing a health service? Do you know when they are available?
- Does the doctor or nurse or some other health unit give advice to the management about improvement of workplace conditions?
- Is there routine contact between the safety committee and the doctor or nurse or other health units responsible for health advice?
- Do you ever discuss workplace problems with any doctor or nurse?
- Have there been any improvements suggested or actually implemented based on the advice by health specialists? If not – why not?



## Safety and hygiene practices

The importance of safety and hygiene cannot be overstressed. It is very important in preventing accidents and promoting health of the workers. Failure to follow safety rules can put workmates at risk.

Safety practices must go hand in hand with the improvement of workplace conditions. It is essential that each worker participate in finding unsafe conditions and suggesting corrective action. Everybody should be a participant in workplace inspections. Such participation is accelerated when safety rules and practices are observed by all.

The concept of accident-prone workers was based on observations that, while some workers had no accidents, others had several in a certain period of time – in other words, some workers were more apt to have accidents than others. It also meant that some workers “prone” to accidents were particularly careless. Although this idea received some support in the past, it has now largely been denied. It is far more likely that some workers are victims of the law of probability or deal with more working conditions.

Underestimation of risks may lead to a false feeling of security and to indifference toward safety. All employers, managers, supervisors, workers, and government officials must continually stress the importance of safety as part of every task. Measures must be taken by all parties to constantly reinforce safety issues.

### Safety

In order to keep safe, all workers should:

- take* care of their own safety;
  - take* responsibility for safety of other persons who may be affected by their acts or omissions;
  - comply* with safety instructions;
  - use* safety devices and protective equipment correctly;
  - report* to the supervisor any situation that could present a hazard which he cannot correct;
  - report* any accident or occupational illness that arises in connection with work.
- drink clean, potable water
  - never eat in locker rooms, washrooms or where dangerous materials are used
  - wash your hands and the exposed parts of the body regularly and take daily baths
  - clean your teeth and mouth daily and have periodic dental check-ups
  - wear proper clothing and footwear
  - do not mix up working and street clothes
  - clean working clothes, towels, etc., particularly when they get contaminated, with the help of a special laundry
  - wear protective masks, glasses, gloves, ear-plugs, etc. according to instructions
  - keep physically healthy with regular exercise.



*Workshops should have their own safety rules displayed on the workshop wall. Learn these rules.*

### Hygiene

Good hygiene is always necessary. Good practice in personal hygiene is difficult unless adequate sanitary facilities are provided. It is also the responsibility of each worker to make best use of the provided facilities.

Good hygiene is essential for workers exposed to toxic chemicals, (especially chemicals which may be allergy-producing or absorbed through the skin), to heat, and to dirty work. To practise good hygiene, remember to:

- drink clean, potable water
- never eat in locker rooms, washrooms or where dangerous materials are used
- wash your hands and the exposed parts of the body regularly and take daily baths
- clean your teeth and mouth daily and have periodic dental check-ups
- wear proper clothing and footwear
- do not mix up working and street clothes
- clean working clothes, towels, etc., particularly when they get contaminated, with the help of a special laundry
- wear protective masks, glasses, gloves, ear-plugs, etc. according to instructions
- keep physically healthy with regular exercise.

People working with dangerous dusts should shower and wash their hair after work. Dirty working clothes should be changed periodically. Different clothes should be worn for work and for time off. In most industries, it



is necessary to have separate lockers for working clothes and street clothes.

Sanitary areas such as toilets and washrooms, should be near the workplaces and cleaned regularly. Workers need to co-operate in keeping these clean.

'Flu and intestinal complaints can spread rapidly from one worker to another. Those who have 'flu, acute intestinal complaints or infectious boils should stay away from work until the doctor clears them.

*Personal hygiene is very important in terms of reducing health hazards when using chemical products such as epoxy, isocyanides, lead and pesticides. Do not allow your dirty clothes to spread hazardous substances to your own home and family.*

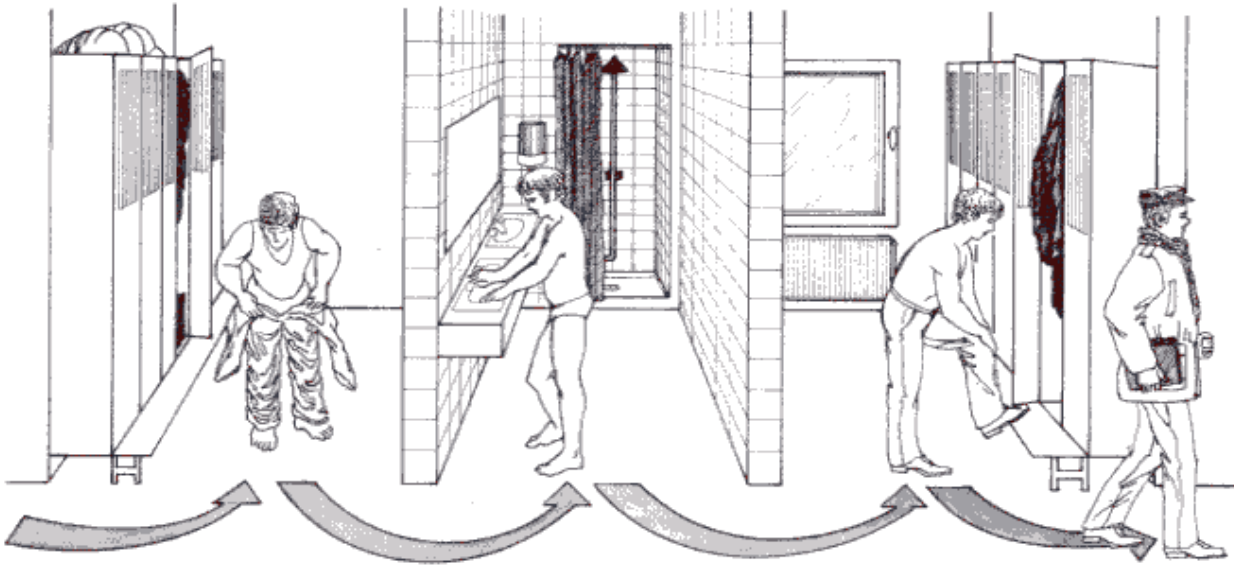

### Points to remember!

- An important part of good personal hygiene is washing at least your hands before sitting down to eat, after using the toilet, and when the work is over.  
Substances such as solvents, alkalis, and machine oils should never be used for cleaning the skin.

### Discussion

- Is safety discussed in a morning meeting or other occasions?
- Does everyone comply with the safety instructions given to workers? If not, why not?
- Do workers wash their hands before eating or smoking?
- Do you change your work clothes in a proper way?
- How is the cleaning done at your workplace

### Welfare facilities

Various welfare facilities and services for workers should be provided by enterprises. They are an essential part of good working conditions. They are important both during working hours and to ensure better conditions of life.

The types and quality of welfare facilities may be different in different undertakings. Good facilities contribute not only to the welfare of workers but also to production and better relations. Adequate, clean sanitary facilities, cool, potable water and inexpensive nutritious food affect health, nutrition and quality of work.

### Facilities for workers' welfare during working hours

- Facilities for personal sanitation (toilets, washing facilities, cloakrooms and lockers or places for drying and storing working clothes) should be provided near workplaces;
- access to drinking water or other beverages and to canteens or other food services;
- facilities to help reduce fatigue, such as seats, rest areas, or recreation facilities.

The workplace should have good sanitary facilities: toilets, washing facilities and shower rooms. Toilets and washrooms should be separate, among other reasons to prevent the spread of bacteria. The management should employ someone with responsibility for keeping the toilets clean, and make sure that the cleaning is done everyday.

*Drinking water an adequate number of hygienic toilets and washing facilities are basic requirements of workplace sanitation. Repair of these must be given priority.*

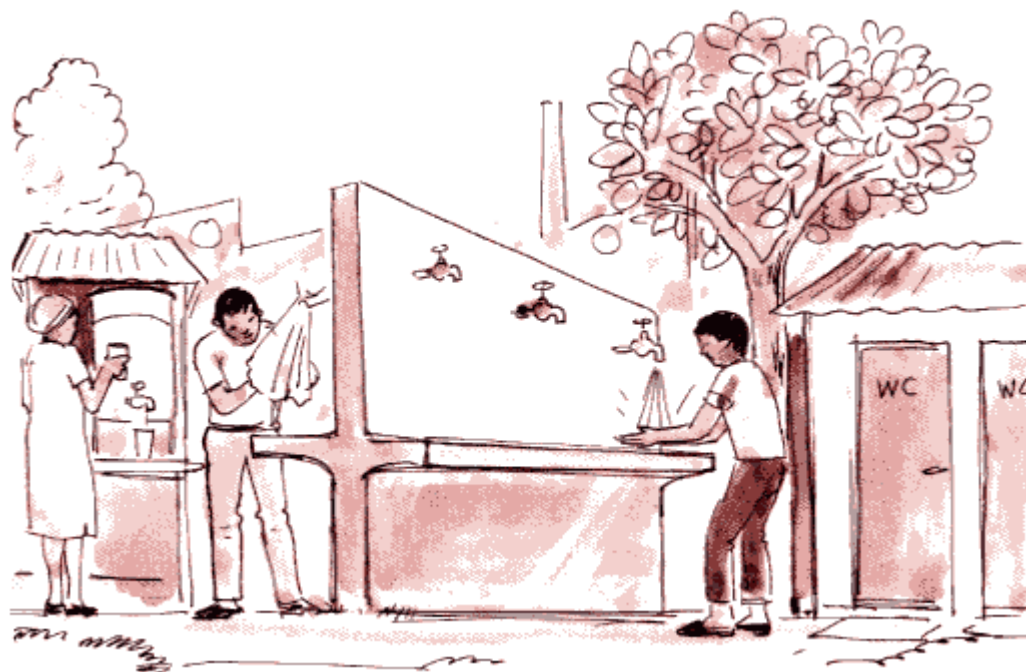

## Canteen services

Canteen services are extremely useful as the nutrition of workers is often poor and inadequate, especially in developing countries. Cases have been reported where workers arrive at work without having eaten enough and, since there are no canteens, work without any meals through their working hours. In such cases, output is low and the absenteeism rate high. In planning workers' meals, both quantity (enough calories) and quality (nutritional balance) are important. Where possible, canteens providing full-sized, balanced meals should be available.

In undertakings where the provision of canteens is not practicable, snack services or meal-preparing rooms should be provided. Snack trolleys, however, should not be introduced into workplaces where dangerous or harmful processes make it undesirable to eat there.

Special consideration should be given to shift workers. They should be able to obtain meals and beverages at appropriate times.

In small and medium-sized enterprises, arrangements should also be made to provide workers with access to meals. Examples of such arrangements include group restaurants, delivery of cooked or pre-cooked meals, issuing meal vouchers for near-by restaurants or food vendors, subsidy to owners of such facilities, etc.

### Points to remember!

- Welfare facilities provide benefits for the enterprise as well as luxuries. Welfare facilities provide benefits for the enterprise as well as for the worker. Sanitary facilities and drinking water are essential, followed by facilities for meals, rest, commuting, etc.

*A place where short breaks can be taken close to the work station, and canteens that serve good, nutritious food in pleasant surroundings have a major effect on employees' well-being. People working in hot climates need to drink a lot of fluids, which should be readily available.*

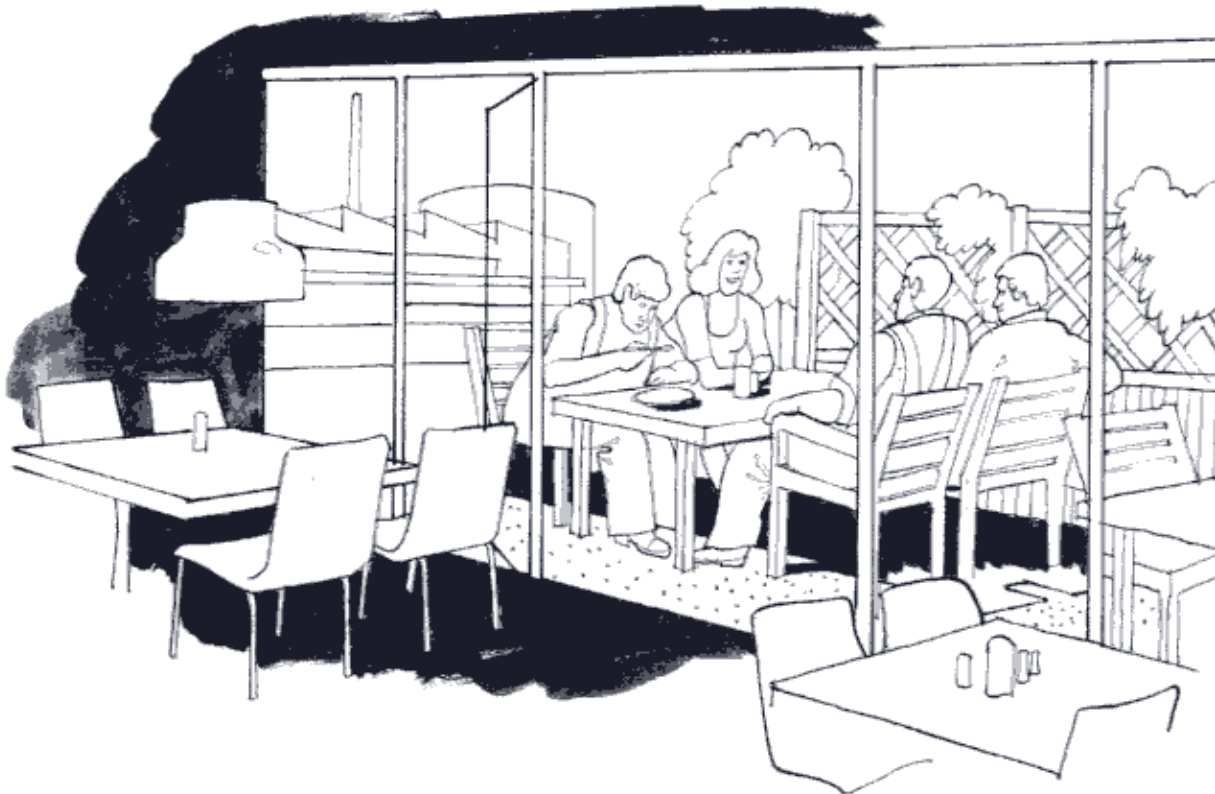

## Welfare facilities to improve living conditions

- Assistance in providing good housing for workers, for example by promoting ownership or rental of houses or apartments;
- providing facilities for commuting, where necessary;
- low-price stores or other facilities to ensure regular supplies of food and other necessary goods;
- access to health care in the case of sickness or accident;
- facilities to improve education and in particular to ensure literacy;
- sports and recreational facilities;
- child-care facilities and social assistance.

Problems of housing and living conditions are often related to urbanisation and worsened by rapid industrialisation. Conditions of life must be given adequate consideration at the planning stage. As the efforts by each undertaking are limited, support by public programmes and participation of employers' and workers' organisations are important.

In the case of *housing*, assistance in construction or rental of accommodation can be helpful, including programmes of home-financing savings or special loans, regular help for entry into low-cost house-building programmes, providing building materials at reduced prices, etc. Except for undertakings in remote places or jobs requiring short-notice assignment, employers rarely provide housing directly. Therefore, good city planning and long-term housing plans are necessary.

Long *commuting* distances and times add considerably to fatigue at work. An increase in commuting times in growing cities and in large industrial zones is seen in many countries. The impact of any reduction in working hours on workers' leisure and rest may be reduced or even cancelled by time-consuming commuting. The cost of daily commuting often exceeds a reasonable percentage of wages.

Various measures can be taken to improve this situation: requests for improvements in public transport, better co-ordination between transport timetables and working hours, introduction of staggered or flexible hours, providing company bus services, and loans for purchasing motorcycles or bicycles.

*Work-related low-price stores* are being set up increasingly in many countries. These stores should sell

basic goods at reasonable prices. Their purpose should not be profit. Consumer co-operative stores can be promoted. Training in management of these stores is particularly helpful.

Setting up *health-care services, access to education and child-care facilities* is also very important. It should be remembered that in some sectors and especially in developing countries, there is no suitable “infrastructure” for these services and facilities. When the undertaking does not directly provide these services for workers, support should be given in order to make independent, public or private services available. Examples include granting advances or low-interest loans, encouragement for joining health insurance schemes or savings, agreements between undertakings on public or private health care services, etc.

### Points to remember!

- Joint efforts of employers and workers are important in improving welfare facilities. There are many forms of action. Practical steps should be taken and evaluated after some time.

### Discussion

- List the welfare facilities workers can use during working hours. Are they sufficient in number?
- Are the basic sanitary facilities, such as toilets, washing facilities and drinking water supply, easy to reach, well maintained and quickly repaired?
- Do you have canteen facilities where you can get balanced meals at meal breaks?
- What steps can be taken to help your housing or commuting problems?

## Efforts towards safety, health and working conditions



**Reduce pollution by choosing less hazardous materials and work methods.**

Wide-scale improvements can only be made in safety, health and working conditions if people work together. Active participation of governments, management and workers must be the basis of these improvements.

Safety, health and working conditions is an appropriate area for increased activity and commitment by both the employer and the employees at individual workplaces. One reason is that the workplace problems are near at hand – all workers and supervisors are affected by poor working conditions. *Everybody can decide for himself whether his workplace conditions are good or bad* and everybody can make suggestions or observations on how to improve the quality and safety of their own work. We can all see the results of our mutual efforts.



## Information

An important element in our activity for safety, health and well-being at work is *information*, including information provided by *management to workers* and the information which is passed *between colleagues*.

It should not solely consist of instructions or directives concerning work issued by the managers or supervisors. If information on safety, health and working condition questions in an enterprise is effective then it should stimulate all the workers and supervisors to participate in occupational health and safety activities. Proper information contributes to a general feeling of *job satisfaction* and good working morale in the enterprise.

Information can be provided in different ways. In addition to information being passed by words of mouth, special safety campaigns can be organised. Suggestion boxes can be provided (allowing the employees to put forward their own proposals for safety, health and working condition improvements, perhaps with prizes being awarded for those proposals which are adopted). Another way is to provide

information on risks, accidents, new products or new work methods which the enterprise is going to use.

- How could you increase the commitment of all supervisors and workers to a well-designed workplace?
- Are leaflets or other kinds of information material distributed to workers often and in sufficient number?
- Are posters and other exhibited materials often renewed to get your and other workers' attention?
- What sort of information do you think is important for safety, health and working conditions and job satisfaction?

## Discussion

- Do you agree that the question of safety, health and working conditions is an ideal area for joint co-operation of government, management and workers?

*New employees must be given full information by the supervisor and by co-workers. Information must also be provided when introducing new machines, chemicals, production methods, etc. so that the work may be carried out as safely as possible.*



## An active safety committee

Establishing an active safety committee is a prerequisite for joint management and worker efforts for better safety, health and working conditions. The legal and social conditions for setting up such a committee can be different from country to country. The committee may be called a safety committee, a safety and health committee or a specialised unit of a joint management-

worker consultation body. In a very small enterprise, it may not be called a committee, but simply a safety group or a group of persons in charge of welfare. It is important to set it up as an action-oriented group of people in which both management and workers are represented.

The primary purpose of the safety committee is to prevent accidents, but other activities include reviewing occupational safety and health programmes and the



relevant welfare facilities of the enterprise. Thus the committee is involved in corrective measures spanning the entire range of the above mentioned workplace inspections.

The following duties are usually assigned to safety committees:

- *Meet* at regular times to discuss the safety and health programme of the enterprise and to make recommendations to management.
- *Make* systematic inspections of workplace conditions at regular times to discover and report unsafe and unsatisfactory conditions and practices.
- *Review* the circumstances and causes of accidents or occupational illnesses and recommend corrective measures.
- *Discuss* unsafe or unsatisfactory conditions at the workplace.
- *Examine* suggestions that employees make about safety.
- *Plan and supervise* educational activities in safety and relevant areas.

Information given by employees often helps the safety committee. Therefore, the committee members should, in inspection rounds or through their daily contacts, listen to suggestions by employees and bring them up at the committee meeting. Committee members should try to bring up practical suggestions in the committee discussions so that they can be reported to the management for action. The committee should maintain its independent position and base its recommendations on its own observations and careful discussions.

Investigating an accident may not be a routine part of the safety committee's job, but there is hardly a committee that has not been asked to review the circumstances of an accident and find out what caused it. The committee should tactfully help collect accurate information. Remember that the purpose of an accident review is to find out how to prevent similar accidents in the future. The committee should not be involved in making accusations.

Attitudes for safety will grow if people take part in discussions about how accidents can be prevented. The committee should present facts about actual conditions and help organise such discussions. The committee can work effectively when it reports and recommends, and does not complain.



***It is chiefly the safety committee that has overall responsibility for planning and proposing measures to improve the work environment. This includes producing a plan for training courses on work environment issues, taking part in planning the conversion of existing premises, changes in production and work practices, monitoring trends in industrial injuries and, when necessary, carrying out investigations for the occupational health service.***

## Laws and regulations – national and international

In many countries there are laws and regulations which govern conditions of work. These laws and regulations are based on the idea that the improvement of workplace conditions is to be *organised* and performed in *co-operation* with the employer and the workers.

But even if this task of improving the safety, health and working conditions is to be performed in a spirit of co-operation it is the employer who is *principally responsible* for seeing that the different measures proposed to improve the safety, health and working conditions are in fact put into practice.

The costs of improvements in the area of workplace conditions, including occupational health and safety, are a natural part of production costs and not a burden to be borne by the individual worker.

Improvement of the safety, health and working conditions needs foresight and long range planning. The planning work covers *both* the maintenance of existing premises and equipment *and* discussions concerning working condition standards that should be met when acquiring new premises, machinery and equipment.

Efficient, high-quality activity for improving workplace conditions cannot be achieved unless the employer, the workers and their trade union organisations feel that this is desirable.

It is essential to study carefully the laws and regulations and use them as a basis for joint co-operation. Collective agreement between management and workers and the active role of the safety committee will greatly help this co-operation. But never think that those who enforce these laws and regulations will do the necessary work. Voluntary initiative is the basic prerequisite of any improvement to be carried out in the workplace.

### Discussion

- What is the situation in your country? Are there laws governing the working conditions?
- Are there any items in your agreements with the employer which cover the safety, health and working conditions? If so, what are the most important points covered by these provisions?
- Are you insured against industrial injuries?
- Are there safety representatives or a safety committee?
- If “yes”, how do they work in practice?
- If “no”, what are the chances of introducing safety representatives and safety committee?

## International agreements

In addition to the national laws and agreements, there are also different international agreements, declarations and working conditions programmes. These have been drawn up by different United Nation organisations including the *International Labour Organisation (ILO)* and the *World Health Organization (WHO)* and have been adopted by many countries.



Of particular importance are the ILO Conventions and Recommendations concerning conditions of work, occupational safety and health and welfare facilities. These encourage member countries to establish goals for improving workplace conditions.

The need of an integrated approach is emphasised by the ILO's International Programme for the Improvement of Working Conditions and (called PIACT) that started in 1976. This world-wide programme recognises the following principles as fundamental:

- (a) work should take place in a safe and healthy work situation,
- (b) conditions of work should be consistent with workers' well-being and human dignity,
- (c) work should offer real opportunities for personal achievement, self-fulfilment and service to society.

This programme is assisting many countries to cope with various problems relating to working conditions. It is emphasised that effort in occupational safety and health, for example, should be combined with effort in improving working time, job content and welfare. In the international context, greater emphasis is placed on “tripartite” co-operation, that is the co-operation between government, employers and workers.

Another well-known example is the WHO definition of the concept of *health*:

“Health is a state of complete physical, mental and social well being and is not simply the absence of illness or disease.”

In other words, effort in this direction is not simply concerned with preventing physical risks and accidents,

but is concerned with a person's total well-being at the workplace.

## Safety, health and working condition problems must be attacked at source

The best way of dealing with safety, health and working condition problems is to attack them at their source. If a machine is noisy, it is better to reduce the noise it makes than to issue hearing protectors to the people working with the machine. Instead of making workers wear face masks, atmospheric pollution should be excluded or limited to one area.

Making the individual employee wear some form of protective device is always a last resort, but sometimes it is the only way. We must always try to reduce the risks to health as far as possible in order to achieve satisfactory safety, health and working conditions. The aim should be that it must be possible to perform the work without personal protective equipment.

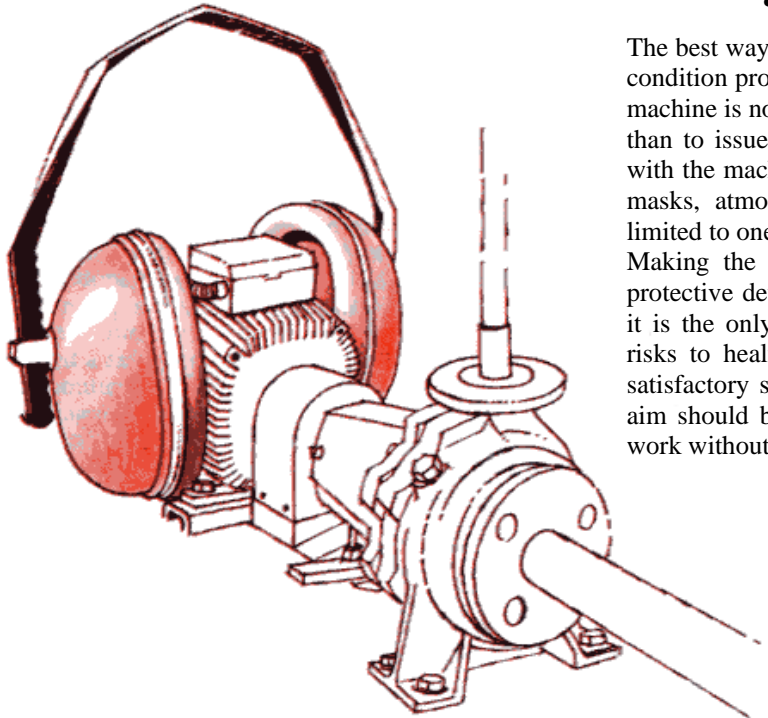

*Put a silencer on the machine instead of ear protectors on the workers.*

## By your active participation make sure safety, health and working conditions come up to standard!

In this material we have listed and described many different safety, health and working condition problems. Seldom do all these problems exist at one workplace or even in one sector of industry.

We have not drawn up this presentation of workplace problems to frighten you. We have done it for three reasons:

- 1) you should be *aware* of the workplace problems that can occur
- 2) you should also be aware that it is *possible to solve* most problems at workplaces
- 3) you should *protect your health* and *make sure that your working conditions are up to standard*.

Everyone has some sort of working career. Do you realise that the worksite where you work now, or where you will be working in the future, is a part of your life?

You spend nearly one-third of your life in working sites and these sites and their working conditions will leave their mark on you.

It is important therefore, that you also leave your mark on the worksite and the working conditions by continually improving and developing them. Make sure that they meet your expectations and demands. Laws and international agreements together with current technical progress encourage development in creating better conditions in working life. We must continually go forward – more people must commit themselves to seeing that the necessary changes are made in every workplace in every country in the world.

## Discussion

---

- Make a list of priorities of changes in the safety, health and working conditions you would like to see.
  - Does your country live up to the spirit of the ILO and other international agreements in the field of working life?
-



### Points to remember!

- It is always more effective to plan from the beginning that your working conditions come up to standard. You must therefore work out an action programme.

A good workplace is profitable in the long run – both for the employers and the country! Workers enjoy a greater measure of job satisfaction and often productivity is increased.

## USEFUL HINTS

### Workplace inspections

- Workplace inspections are carried out regularly by a designated group of people, systematically examining different workplaces.
- When necessary, special workplace inspections are planned and carried out.
- The results of workplace inspections are noted in the form of a report with suggestions for improvements.
- The reports of workplace inspections are kept by a responsible person.
- Inspections start with examining previous inspection reports.
- In carrying out workplace inspections, suitable checklists are used.
- The opinions of workers are reflected in the inspection reports.
- Whenever necessary, advice or services of specialists are provided as soon as possible.

### Health services

- Health services for workers include workplace evaluation from experts' points of view.
- Workers' health is examined at the time of assignment, taking into account the potential hazards.
- All workers' health is checked periodically by a health services team that knows the workplace conditions.
- Workers exposed to specific health risks are checked periodically for possible health changes.
- The results of health checks are made known to the worker.
- The privacy of health data is respected and protected.
- Workers have access to medical care as necessary.
- The health services team recommend corrective action to the management, the safety committee and the worker representatives.

## Safety and hygiene

- Workers co-operate in safety by taking reasonable care for their own and workmates' safety.
- Every worker is trained to observe safety instructions, including the proper use of safety devices and protective equipment.
- A system is established for reporting hazards, accidents or illness.
- Appropriate facilities are available, so that the hands and the exposed parts of the body are regularly washed.
- Substances such as solvents, alkalis, and machine oils are not used for cleaning dirt from skin.
- Working and street clothes are not mixed.
- Arrangement is made to clean working clothes regularly.

## Welfare facilities

- Adequate toilet facilities are provided at a short distance from the work area.
- Washing facilities, separate from toilets, are available near the work area.
- Enough shower rooms are provided.
- Toilets and washing facilities are cleaned everyday by persons assigned for the cleaning.
- Every worker has a locker in a clean locker room.
- There are separate rooms for rest periods.
- Safe, cool water or other beverages are available near the work area.
- A comfortable and hygienic room, separate from the work area, is provided for meals.
- Arrangements are made to ensure the intake of nutritious meals and, where possible, the purchase of low-priced goods.
- Support is given for securing time-saving commuting facilities.
- Workers are assisted in securing good housing.
- Workers have access to child-care facilities when these are needed.
- Sports and recreational facilities are made available.

## Safety committee

- A safety committee is properly organised, appointing its members at regular intervals.
- The safety committee regularly holds its meeting at least once a month.
- The safety committee submits to management the meeting reports including practical recommendations.
- The safety committee discusses the safety and health programme of the enterprise.
- The safety committee or its representatives take part in workplace inspections.
- The safety committee reviews reports of accident investigations and workplace inspections.
- The safety committee plans and supervises safety and health training for employees.

## Training and information

- Every new worker is trained in general principles of safety, health and well-being and on specific hazards at his/her workplace.
- Safety and health re-training is organised during working hours.
- All workers participate in fire drills and know the necessary action in case of a fire.
- Workers in need of personal protective equipment are trained about its proper use.
- Safety representatives and first-aiders get special training.
- The activities of the safety committee, including reports about recent accidents, are made known to all people in the enterprise.
- Specific safety instructions are given, also in written form, to all relevant workers.
- Safety posters are renewed at appropriate intervals.
- Leaflets and other information materials about safety, health and wellbeing are distributed often and in sufficient number.



TODAY'S WORKPLACE is faced with rapid development and accelerating changes in technology. Economic and social developments are also changing the daily life of both blue and white collar worker. Improvements are expected but the conditions of work and the working environment of many workers still remain arduous. Also these changes give rise to new problems. Therefore in many countries the amount of accidents and health problems of workers are increasing.

Can the conditions of work in different countries be improved now so as to meet the needs and the legitimate expectations of workers? This question is of prime importance to governments, employers and workers throughout the world.

This manual is the result of concerted efforts of the Swedish Joint Industrial Safety Council and the International Labour Office with support from the Swedish International Development Agency. It is prepared as a tool for training people directly concerned with workplace improvements. The material has been developed in Sweden and tested with positive result in different countries.



INTERNATIONAL LABOUR OFFICE  
GENEVA SWITZERLAND



JOINT INDUSTRIAL SAFETY COUNCIL ©  
STOCKHOLM SWEDEN

ISBN 91-7522-115-2